

# 5/2-directional valve, Series XV03, with spring return, MO: without detent, Top connection

R572A2B1BMA00F1

Series  
XV03

2025-04-03

## Series XV03

The AVENTICS XV03 Compact series provides a reliable basis for both compact handling systems and complex automation solutions. It comprises a wide range of valve functions and accessories as well as the required electrical connectivity for all requirements in factory automation and other industries. The associated XVES Connectivity module allows for connection options ranging from simple direct control via D-SUB or terminal strips to a variety of fieldbus protocols. Our one-of-a-kind online configurator makes it easy to configure the complete valve system, including accessories, so that it is perfectly tailored to your application needs.

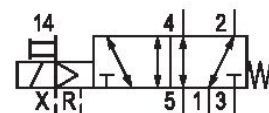

## Technical data

Industry	Industrial
Activation	Electrically operated
Valve type	Spool valve, positive overlapping
Switching principle	5/2, with spring return
Actuating control	Single Solenoid
Connection type	Plate connection
Manual override	without detent
Pilot control exhaust	with directional pilot air exhaust
Nominal flow Qn	345 l/min
Min. working pressure	-0.95 bar
Max. working pressure	8 bar
Min. control pressure	3 bar
Max. control pressure	8 bar
Protection class with connection	IP65
Operational voltage	24 V DC

# 5/2-directional valve, Series XV03, with spring return, MO: without detent, Top connection

R572A2B1BMA00F1

Series  
XV03

2025-04-03

Operational voltage DC	24 V
Voltage tolerance DC	-10 % / +10 %
Pilot	External
LED status display	Yellow
Power consumption DC	0.55 W
Duty cycle	100 %
Typ. switch-on time	15 ms
Typ. switch-off time	30 ms
Blocking principle	Base plate principle, multiple
Certificates	UR (Underwriters Laboratories)
Min. ambient temperature	-10 °C
Max. ambient temperature	50 °C
Min. medium temperature	-10 °C
Max. medium temperature	50 °C
Medium	Compressed air
Min. oil content of compressed air	0 mg/m <sup>3</sup>
Max. oil content of compressed air	5 mg/m <sup>3</sup>
Max. particle size	40 µm
Mounting screws	Hexalobular socket (TORX) ISO 10664-T5
Mounting screw tightening torque	0.25 Nm
Tightening torque tolerance	+0,05
Weight	0.054 kg

## Material

Housing material	Polyamide fiber-glass reinforced
Seal material	Acrylonitrile butadiene rubber Hydrogenated acrylonitrile butadiene rubber
Material front plate	Polyamide fiber-glass reinforced
Material end plate	Polyamide

Part No. R572A2B1BMA00F1

# 5/2-directional valve, Series XV03, with spring return, MO: without detent, Top connection

R572A2B1BMA00F1

Series  
XV03

2025-04-03

---

## Technical information

The min. control pressure must be adhered to, since otherwise faulty switching and valve failure may result!

The pressure dew point must be at least 15 °C less than ambient and medium temperature and may not exceed 3 °C.

The oil content of compressed air must remain constant during the life cycle.

Use only the approved oils from AVENTICS. Further information can be found in the “Technical information” document (available in <https://www.emerson.com/en-us/support>).

# 5/2-directional valve, Series XV03, with spring return, MO: without detent, Top connection

Series  
XV03

R572A2B1BMA00F1

2025-04-03

## Dimensions

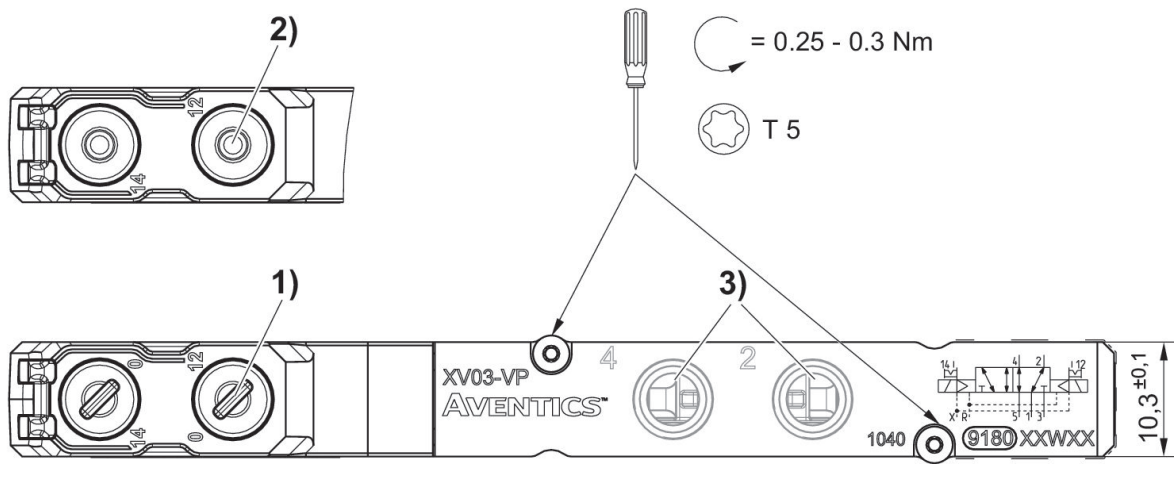
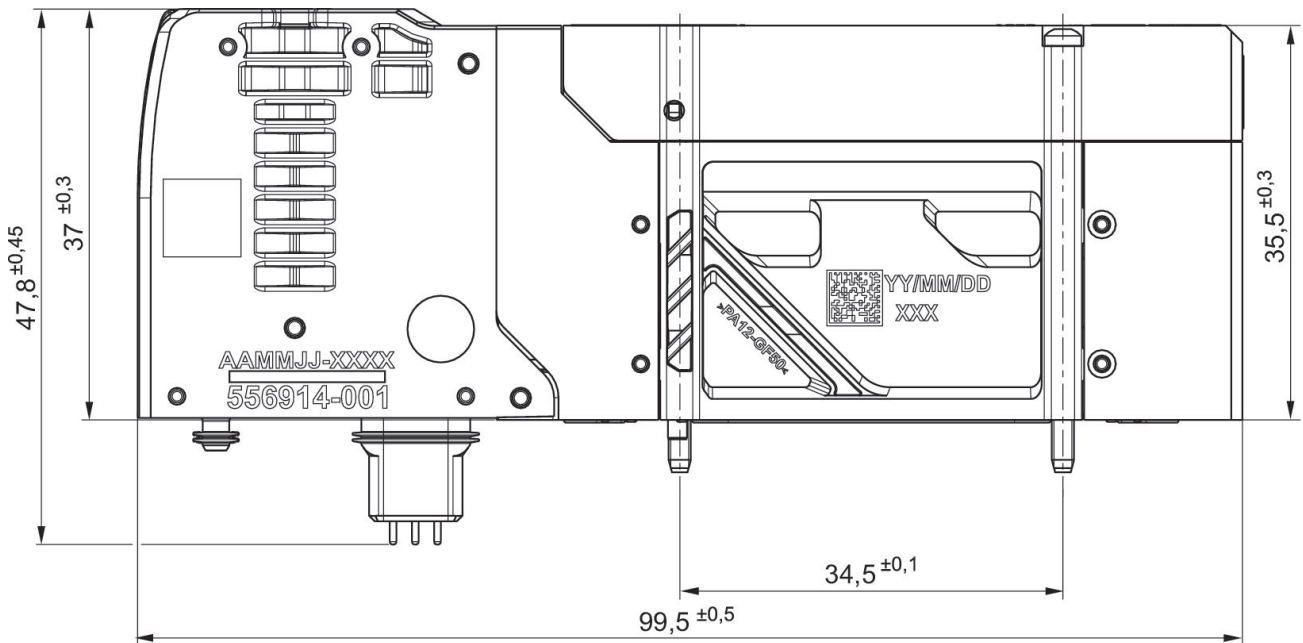

- 1) with detent
- 2) without detent
- 3) Ports: M7