

5/2-directional valve, Series 502

R502A1B10MA00F1

General series information
AVENTICS Series 502 Directional Control Valves

- The AVENTICS Series 502 is a line of general purpose automation valves designed for directional control and piloting applications requiring higher flow rates; less power consumption; and exceptionally easy on-site installation, configuration, and modification. The compact (18 mm), modular 502 Series is ideally suited for automotive and tire, food and beverage, pharmaceutical, and packaging machinery applications. The valve has the flexibility of meeting the ISO 15407-2 standard while maintaining its high-flow characteristics. In addition, no other valve in its class offers such a broad range of pressure regulator, pressure shut-off, and exhaust flow control accessories.

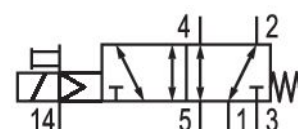

Technical data

Industry	Industrial
Activation	Electrically
Valve type	Spool valve, positive overlapping
Actuating control	Single Solenoid
Sealing principle	metal/metal sealing
Connection type	Plate connection
Pilot control exhaust	with directional pilot air exhaust
Nominal flow Qn	470 l/min
Working pressure min.	-0.95 bar
Working pressure max.	8 bar
Control pressure min.	2 bar
Control pressure max.	8 bar

Protection class with connection	IP65
Protective circuit	Z-diode
Reverse polarity protection	Protected against polarity reversal
Operational voltage	24 V DC
Voltage tolerance DC	-15% / +10%
Pilot	External
LED status display	Yellow
Power consumption DC	1.1 W
Duty cycle	100 %
Typ. switch-on time	16 ms
Typ. switch-off time	49 ms
Blocking principle	Single base plate principle, can be assembled into blocks
Can be assembled into blocks	Can be assembled into blocks
Min. ambient temperature	-10 °C
Max. ambient temperature	50 °C
Min. medium temperature	-10 °C
Max. medium temperature	50 °C
Medium	Compressed air
Oil content of compressed air min.	0 mg/m ³
Oil content of compressed air max.	5 mg/m ³
Max. particle size	50 µm
mounting screws	with hexagon socket
Mounting screw tightening torque	2 Nm
Weight	0.169 kg

Material

Housing material	Die cast zinc
Seal material	Nitrile butadiene rubber Polyurethane
Material front plate	Polyamide
Material end plate	Polyamide
Part No.	R502A1B10MA00F1

Technical information

The min. control pressure must be adhered to, since otherwise faulty switching and valve failure may result!

The pressure dew point must be at least 15 °C less than ambient and medium temperature and may not exceed 3 °C.

The oil content of compressed air must remain constant during the life cycle.

Use only the approved oils from AVENTICS. Further information can be found in the "Technical information" document (available in <https://www.emerson.com/en-us/support>).

Dimensions

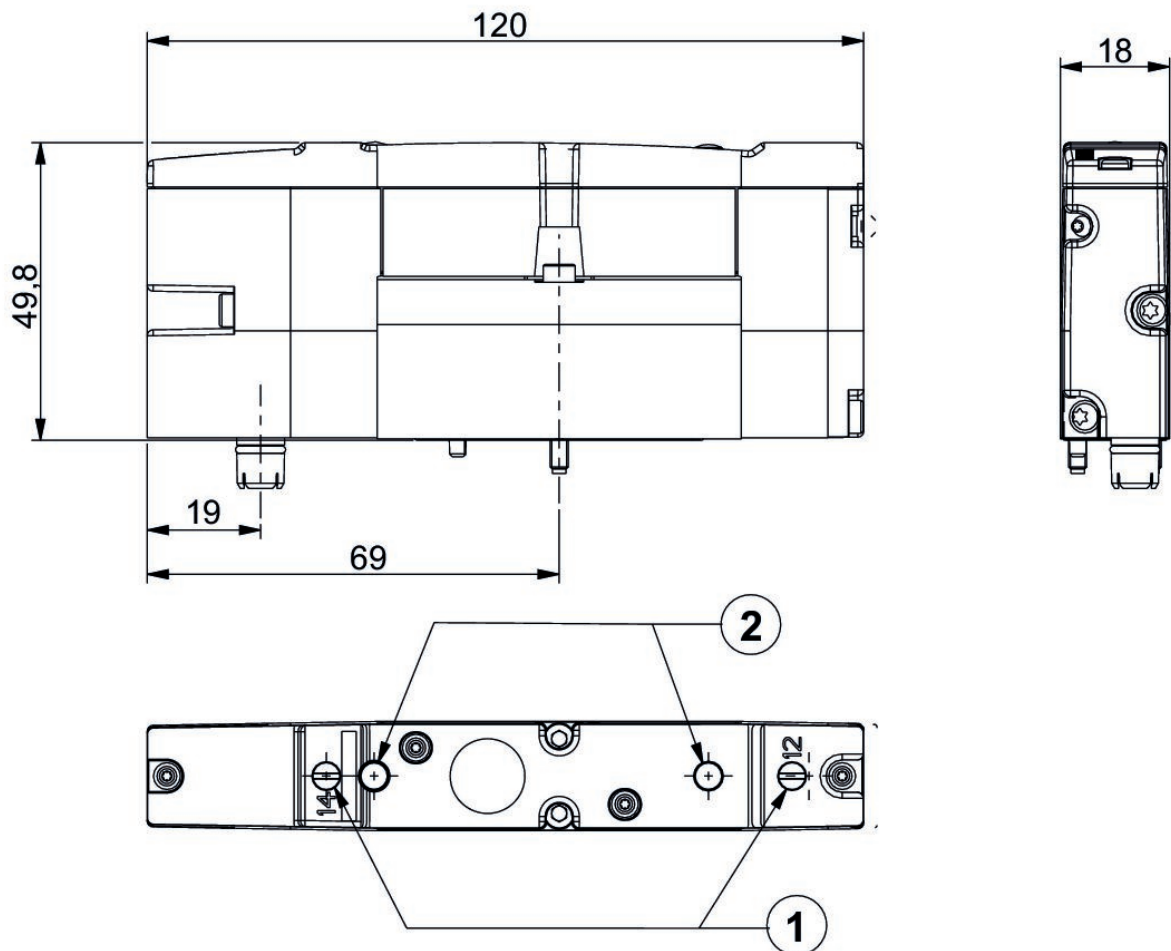

- 1) Manual override
- 2) LED