

Rodless cylinders, Series CKP

R480163941

AVENTICS
Series CKP
Rodless
cylinders

2024-03-19

AVENTICS Series CKP Rodless cylinders

The AVENTICS Series CKP cylinders provide sturdy, ultra-precise guiding with excellent repeatability and are ideal for applications requiring the movement of heavy loads in space-critical machine environments.

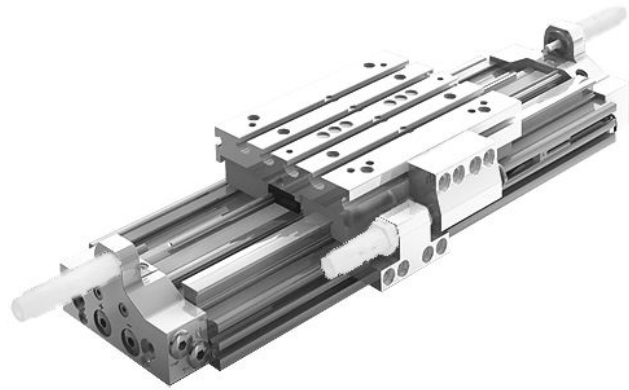

Technical data

| | |
|--|--|
| Industry | Industrial |
| Piston Ø | 16 mm |
| Stroke | 400 mm |
| Ports | M7 |
| Functional principle | Double-acting |
| Magnetic piston | with magnetic piston |
| Guide | ball rail guide |
| Easy2Combine | Easy2Combine capable with connection kit |
| Piston force | 127 N |
| Pressure for determining piston forces | 6,3 bar |
| Cushioning length | 20 mm |
| Cushioning energy | 1.5 J |
| Cushioning | Pneumatically |
| Cushioning | adjustable |
| Max. speed | 2 m/s |
| Stroke max. | 1800 mm |
| Min. working pressure | 3 bar |
| Max. working pressure | 8 bar |
| Min. ambient temperature | -10 °C |

Rodless cylinders, Series CKP

R480163941

AVENTICS
Series CKP
Rodless
cylinders

2024-03-19

| | |
|--------------------------|----------------|
| Max. ambient temperature | 60 °C |
| Min. medium temperature | -10 °C |
| Max. medium temperature | 60 °C |
| Medium | Compressed air |
| Max. particle size | 5 µm |
| Weight | 3.6 kg |

Material

| | |
|-------------------------|---------------------------------|
| Material front cover | Aluminum |
| Surface cover | anodized |
| Seal material | Polyurethane |
| Material sealing strips | Polyurethane Stainless Steel |
| Material guide rail | Aluminum |
| Surface ball rail table | anodized |
| Material guide rail | Steel, chrome-plated |
| Surface guide rail | hardened |
| Part No. | R480163941 |

Technical information

The pressure dew point must be at least 15 °C less than ambient and medium temperature and may not exceed 3 °C.

The delivered product is lubricated for lifetime.

This product may only be operated with oil-free, dry compressed air.

SA = stroke adjustment with use of shock absorber. Adjustment made with adjustment screw. Shock absorber can be replaced without readjustment of end position.

The pressure dew point must be at least 15 °C less than ambient and medium temperature and may not exceed 3 °C.

The oil content of compressed air must remain constant during the life cycle.

Use only the approved oils from AVENTICS. Further information can be found in the "Technical information" document (available in <https://www.emerson.com/en-us/support>).

Rodless cylinders, Series CKP

R480163941

AVENTICS
Series CKP
Rodless
cylinders

2024-03-19

Dimensions

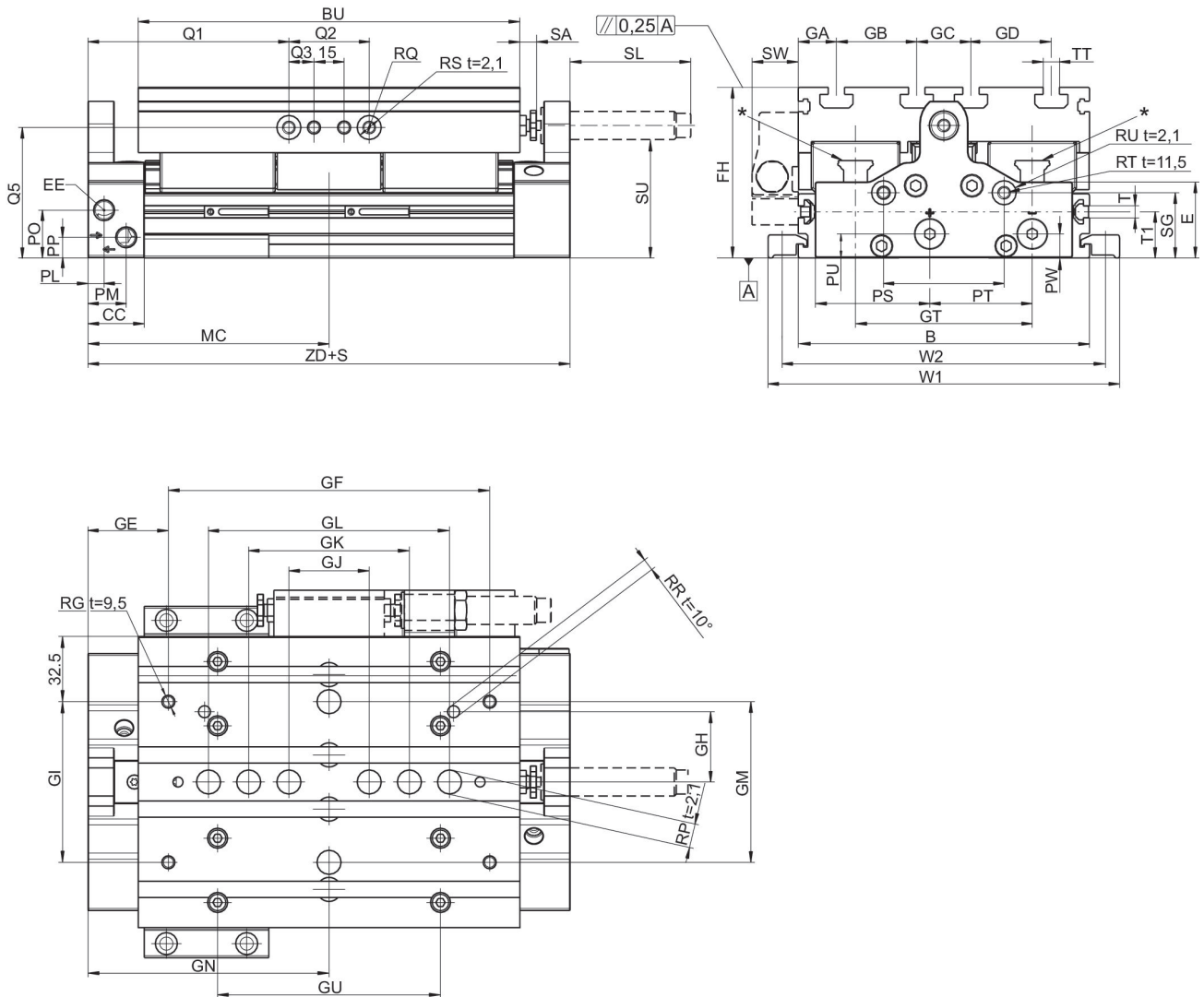

t = depth

* CKP 16: 2x Lube ports on each runner block, CKP 25 / 30: Lube nipple of funnel type with thread connection M3

| Piston Ø | B | Ø RW t = depth of thread | RX t = depth of thread | GX | E | BU | CC | EE | FH |
|----------|-----|-----------------------------|---------------------------|----|------|-----|----|-------|----|
| 16 | 90 | 9 H7 t=2,1 | M4 t=7,5 | 38 | 27.3 | 125 | 28 | M7 | 56 |
| 25 | 110 | 9 H7 t=2,1 | M5 t=9 | 46 | 31.4 | 155 | 28 | G 1/8 | 66 |
| 32 | 145 | 12 H7 t=2,1 | M6 t=13 | 62 | 37.8 | 190 | 28 | G 1/8 | 85 |

| Piston Ø | GA | GB | GC | GD | GN | GE | GF | GH | GI |
|----------|----|----|----|----|-------|------|-----|----|----|
| 16 | 15 | 20 | 20 | 20 | 93.5 | 38.5 | 110 | 20 | 40 |
| 25 | 25 | 20 | 20 | 20 | 107.5 | 47.5 | 120 | 42 | 80 |
| 32 | 19 | 40 | 27 | 40 | 120 | 40 | 160 | 35 | 80 |

| Piston Ø | GJ | GK | GL | GM | GT | GU | MC | PL | PM |
|----------|----|----|----|----|----|----|------|----|----|
| 16 | 40 | 60 | 80 | - | 57 | 80 | 93.5 | 8 | 21 |

Rodless cylinders, Series CKP

R480163941

AVENTICS
Series CKP
Rodless
cylinders

| Piston Ø | GJ | GK | GL | GM | GT | GU | MC | PL | PM |
|----------|----|----|-----|----|----|-----|-------|----|----|
| 25 | 40 | 60 | 80 | – | 66 | 106 | 107.5 | 8 | 20 |
| 32 | 40 | 80 | 120 | 80 | 88 | 111 | 120 | 8 | 19 |

| Piston Ø | PO | PP | PS | PT | PU | PW | Q1 | Q2 | Q3 |
|----------|------|------|------|------|------|------|------|----|------|
| 16 | 12.8 | 6.8 | 33 | 29.8 | 6.8 | 6 | 73.5 | 40 | – |
| 25 | 22 | 10.5 | 37.5 | 24 | 10.5 | 10.5 | 87.5 | 40 | 12.5 |
| 32 | 23.8 | 10.3 | 57 | 51 | 12 | 12 | 100 | 40 | 12.5 |

| Piston Ø | RG | Ø RP | RQ t = depth of thread | Ø RR | Ø RS | RT | Ø RU | SG | SL |
|----------|----|-------|------------------------|------|-------|----|-------|------|----|
| 16 | M5 | 9 F7 | M5 t=10,5 | 4 F7 | 9 F7 | M6 | 12 F7 | 20.3 | 43 |
| 25 | M5 | 9 F7 | M6 t=14,5 | 5 F7 | 12 F7 | M6 | 12 F7 | 14 | 60 |
| 32 | M6 | 12 F7 | M6 t=14,5 | 6 F7 | 12 F7 | M6 | 12 F7 | 32.5 | 60 |

| Piston Ø | SU | SW | T | TT | W1 | W2 | T1 | ZD | SA |
|----------|----|----|----|----|-----|-----|----|-----|------|
| 16 | 37 | 20 | M4 | N6 | 112 | 102 | 16 | 187 | 0–10 |
| 25 | 43 | 23 | N6 | N6 | 140 | 126 | 20 | 215 | 0–10 |
| 32 | 59 | 23 | N6 | N8 | 175 | 161 | 23 | 240 | 0–10 |

| Piston Ø | Moving mass kg |
|----------|----------------|
| 16 | 0.64 |
| 25 | 1.11 |
| 32 | 2.62 |

Permissible forces F_x , F_y , F_z and torques M_x , M_y , M_z

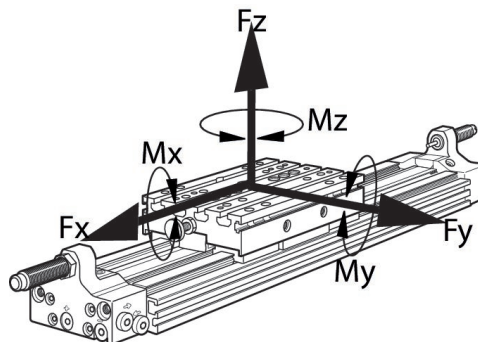

With simultaneously moments on the cylinder this equation must be used in addition to the maximum moments check. In the cushioning phase of the

movement additional forces occur and must be considered. Please use our calculation tool for rodless cylinders on the <http://www.aventics.com>.

Max. dynamic forces and torques

| Piston Ø | F_x [N] | F_y [N] | F_z [N] | M_x [Nm] | M_y [Nm] | M_z [Nm] |
|----------|-----------|-----------|-----------|------------|------------|------------|
| 16 | 2912 | 2912 | 2912 | 83 | 116 | 143 |
| 25 | 3280 | 3280 | 8568 | 283 | 454 | 205 |
| 32 | 5280 | 5280 | 15620 | 687 | 867 | 374 |

Recommended values for an expected lifetime of 3200 km