

Bellow actuator with cover, series BCP, double, air connection above 3 mounting holes

ASND51-7-1

BCP
2024-09-12

Series BCP

Bellows actuators with flanged connectors
Force max. 12000 Lbf
Stroke max. 11,22 inch

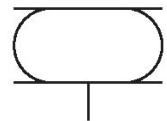

Technical data

Industry	Industrial
Bellows	double
Type	Bellow actuator with cover
Functional principle	Single-acting, retracted without pressure
Compressed air connection	3/4 NPT
Cover diameter	228 mm
Max. permissible angle of tilt	20 °
Max. effective stroke	189.99 mm
Min. radial installation space	340 mm
Min. installation height	75 mm
Max. installation height	265 mm
Min. force	17000 N
Max. force	35400 N
Min. working pressure	0 bar
Max. working pressure	8 bar
Min. ambient temperature	-40 °C
Max. ambient temperature	70 °C
Medium	Compressed air
Reduced service life at a temperature greater than	50 °C

Bellow actuator with cover, series BCP, double, air connection above 3 mounting holes

BCP
2024-09-12

ASND51-7-1

Pressure for determining forces 6 bar

Weight 4.8 kg

Material

Material bellow	Natural rubber
Material front cover	Steel, chrome-plated
Surface cover	galvanized
Part No.	ASND51-7-1

Technical information

Compliance with the minimum height H min. as well as the maximum height H max. must be ensured with end stops.

Use at operating height $\geq H_{max}$: only permitted upon approval by AVENTICS

Further information on vibration isolation can be found in the "Technical information" document (available in the MediaCentre).

Reduced service life at a temperature greater than

The pressure dew point must be at least 15 °C less than ambient and medium temperature and may not exceed 3 °C.

The oil content of compressed air must remain constant during the life cycle.

Use only the approved oils from AVENTICS. Further information can be found in the "Technical information" document (available in <https://www.emerson.com/en-us/support>).

Bellow actuator with cover, series BCP, double, air connection above 3 mounting holes

BCP
2024-09-12

ASND51-7-1
Dimensions

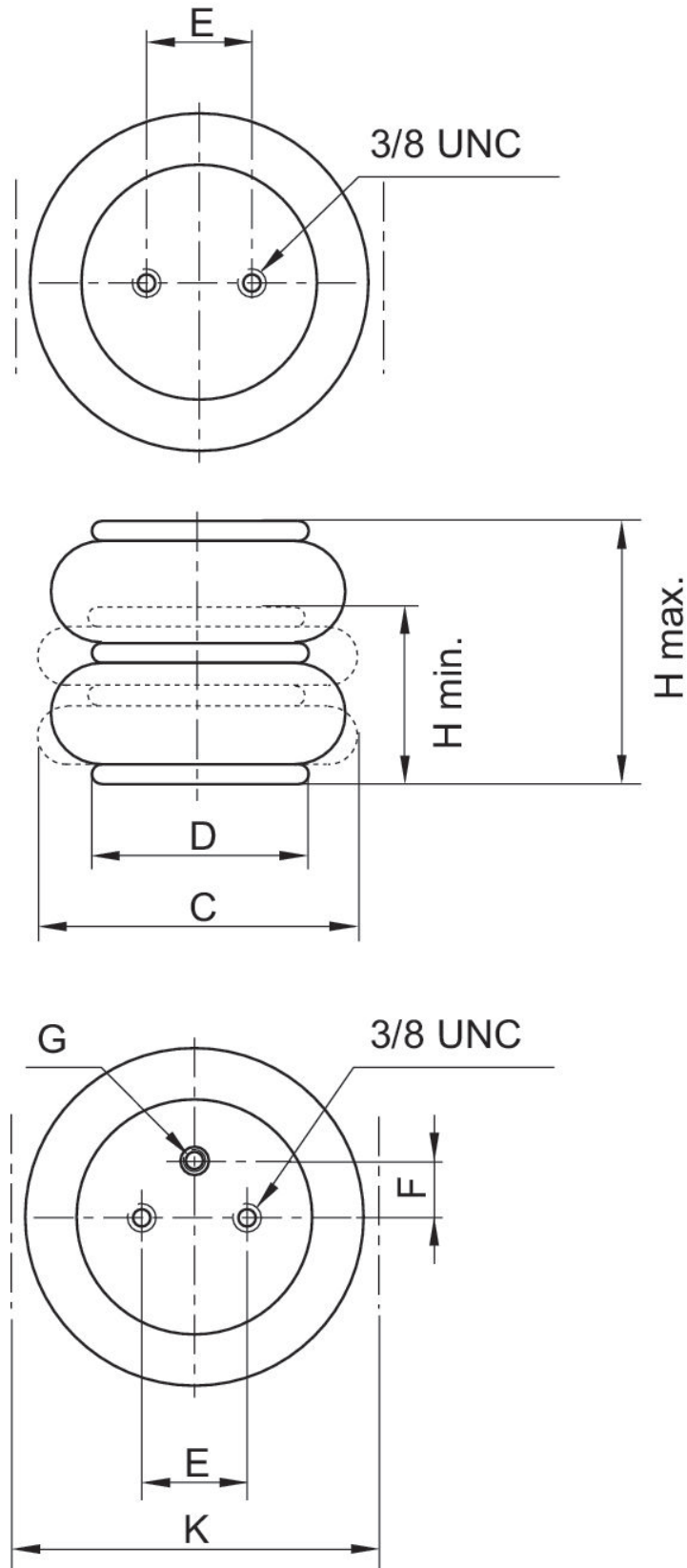

Bellow actuator with cover, series BCP, double, air connection above 3 mounting holes

BCP
2024-09-12

ASND51-7-1

Part No.	Compressed air connection	H min. in	H max. in	C in	D in	E ±0,5 in	F ±0,5 in	K in	Min. return force lbf
ASND31-6-1	3/4 NPT	3.0	9.45	9.84	6.34	3.5	1.5	10.43	45
ASND31-8-1	3/4 NPT	3.0	11.80	10.24	6.34	3.5	1.5	10.83	56
ASND51-7-1	3/4 NPT	3.0	10.40	12.80	8.98	6.2	2.87	13.39	67
ASND51-8-1	3/4 NPT	3.0	11.80	13.39	8.98	6.2	2.87	13.98	67

Comment

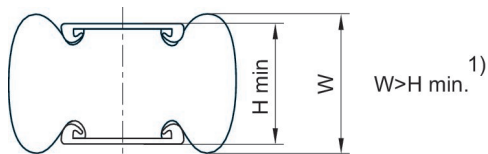

1) Once the minimum height H min. is reached, the bead height W can fall below the lower limit. If, for these products, level mounting surfaces greater than the cover diameter are selected, the return force and force output at the start of stroke increase. In the process, the rubber bellow is also compressed by the mounting surfaces. These products require more space upward, which can, in rare cases, present a hindrance. In any case, the specifications of the data sheets apply when using mounting surfaces in the size of the bellows actuator cover.
1 kN = 1000 N

Force-displacement diagram

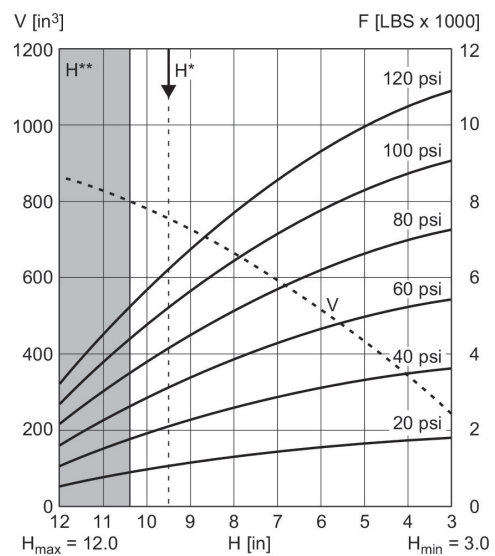

V = volume H = height H* = recommended operating height for vibration isolation H** = use permitted only upon approval by AVENTICS