

5/3-directional valve, Series CD07

R432016597

2025-12-08

Nominal flow Qn	900 l/min
Nominal flow Qn 1 to 2	900 l/min
Nominal flow Qn 2 to 3	900 l/min
Min. working pressure	3 bar
Max. working pressure	10 bar
Min. control pressure	3 bar
Max. control pressure	10 bar
Electrical connection type	Plug
Electrical connection size	EN 175301-803, form A
Electrical connection number of poles	3-pin
Connector standard	EN 175301-803:2006
Protection class with connection	IP65
Reverse polarity protection	Protected against polarity reversal
Operational voltage	110 V AC
Operational voltage AC at 50 Hz	110 V
Voltage tolerance AC 50 Hz	-10 % / +10 %
Operational voltage AC at 60 Hz	110 V
Voltage tolerance AC 60 Hz	-10 % / +10 %
Pilot	Internal
Coil width	30 mm
Compatibility index	52
Holding power AC 50 Hz	3.7 VA
Holding power AC 60 Hz	3.7 VA
Switch-on power AC 50 Hz	6.4 VA
Switch-on power AC 60 Hz	6.4 VA
Duty cycle	100 %
Typ. switch-on time	25 ms
Typ. switch-off time	55 ms
Min. ambient temperature	-15 °C
Max. ambient temperature	50 °C
Min. medium temperature	-15 °C
Max. medium temperature	50 °C
Medium	Compressed air
Min. oil content of compressed air	0 mg/m ³

5/3-directional valve, Series CD07

R432016597

2025-12-08

Max. oil content of compressed air	1 mg/m ³
Max. particle size	50 µm
Mounting on manifold strip	P-strip PRS strip
Weight	0.72 kg

Material

Housing material	Die cast zinc Polyamide, fiber-glass reinforced
Seal material	Acrylonitrile butadiene rubber
Part No.	R432016597

Technical information

ATEX optional: ATEX version can be produced by combining the basic valve without coil with an ATEX coil. ATEX ID: see ATEX coils catalog page.

The min. control pressure must be adhered to, since otherwise faulty switching and valve failure may result!

The pressure dew point must be at least 15 °C less than ambient and medium temperature and may not exceed 3 °C.

The oil content of compressed air must remain constant during the life cycle.

Use only the approved oils from AVENTICS. Further information can be found in the "Technical information" document (available in <https://www.emerson.com/en-us/support>).

5/3-directional valve, Series CD07

R432016597

2025-12-08

Dimensions in inches

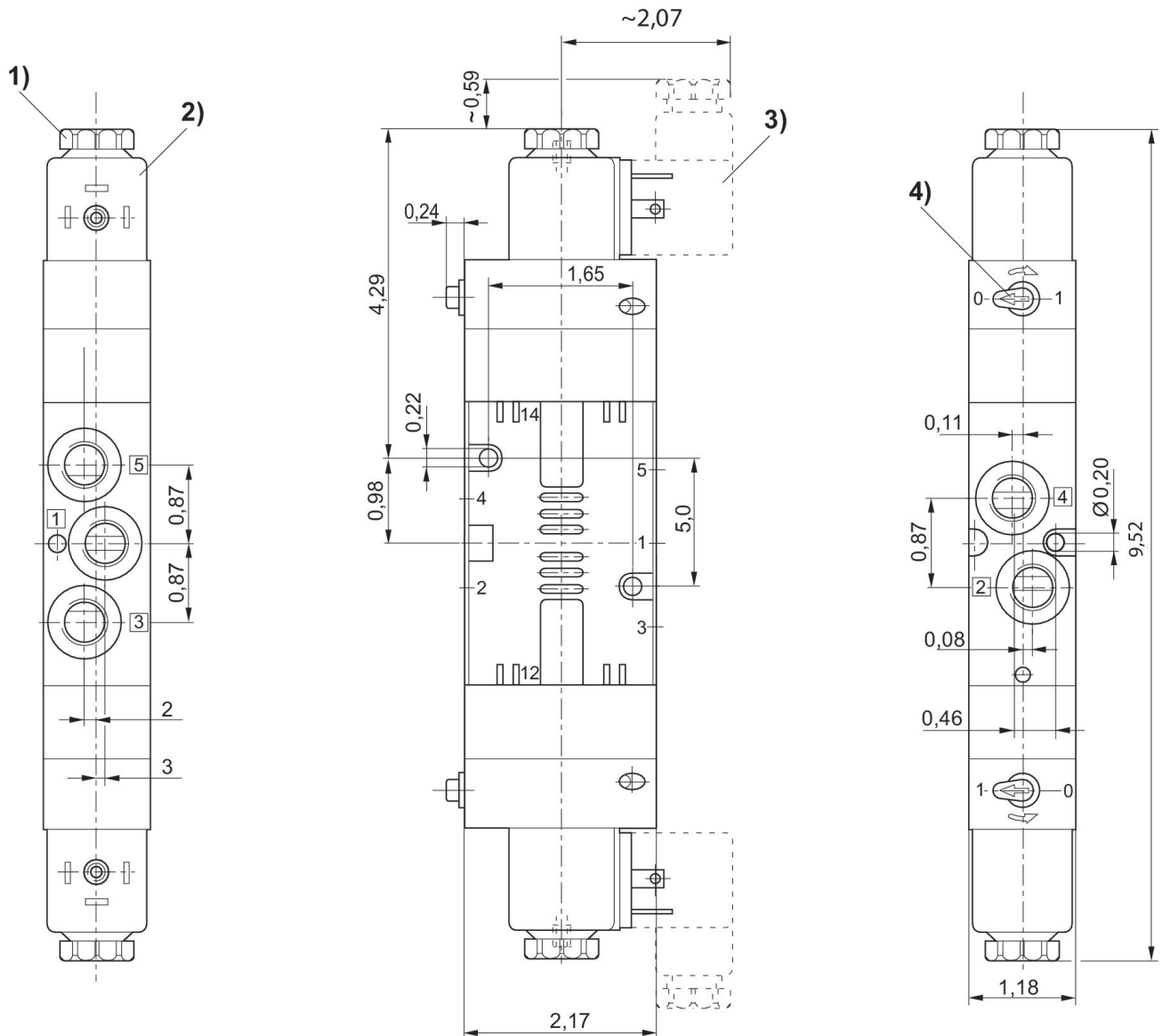

- 1) After removal of cap M5 internal thread
- 2) Coil can be plugged at 45° intervals
- 3) Valve plug connector
- 4) Manual override