

Montajes de brida AVENTICS



Dati tecnici

Settore	Industria
Normalizzazione	NFPA
Diametro pistone	50.8 mm
Peso	0.0362 kg

Materiale

Materiale corpo	Alluminio
Codice	R432012520
Dimensioni in pollici	

Fissaggio a flangia, Serie MF1, MF2

R432012520

Fissaggi a
flangia

2023-11-14

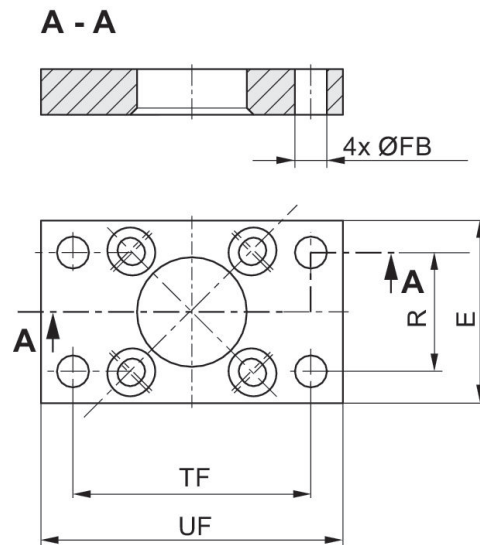

Dimensioni in pollici

Codice	Ø	E	Ø FB	R	TF	UF
R432013373	38.1	2.00	0.34	1.43	2.75	3.38
R432012520	50.8	2.50	0.41	1.84	3.38	4.13
R432013382	63.5	3.00	0.41	2.19	3.88	4.63
R432013388	82.55	3.50	0.47	2.76	4.69	5.50
R432013396	101.6	4.50	0.47	3.32	5.44	6.25