

AVENTICS Series 840 Directional valves

The AVENTICS Series 740/840 feature directional valves with soft, abrasion-free diaphragm technology. The simple, reliable and robust design is suitable for all air qualities and ensures high repeatability and unsurpassed service life. Due to its high resilience, the corrosion-resistant polyamide housing is also suited for dusty and damp environments.



Technical data

Industry	Industrial
Activation	Electrically
Valve type	Diaphragm poppet valve
Switching principle	4/2, double solenoid
Actuating control	Double Solenoid
Sealing principle	Soft seal
Connection type	Pipe connection
Manual override	with detent
Compressed air connection input	1/4" NPTF
Compressed air connection output	1/4" NPTF
Compressed air connection, exhaust	1/4" NPTF
Compressed air connection pilot exhaust	Ø 4,5
Nominal flow Qn	200 l/min
Min. working pressure	1.8 bar
Max. working pressure	10 bar

4/2-directional valve, Series 840 - inch

Series 840

R432008665

2025-07-21

Note	The maximum operating pressure depends on the ambient temperature. The following values are applicable: -15 °C ... 50 °C: Operating pressure [[1.8] bar] ... [[8] bar] possible. -15 °C ... 40 °C: Operating pressure [[1.8] bar] ... [[10] bar] possible.
Min. control pressure	1.8 bar
Max. control pressure	10 bar
Electrical connection type	Plug
Electrical connection size	EN 175301-803, form C
Connector standard	EN 175301-803, form C
Protection class with connection	IP65
Reverse polarity protection	Protected against polarity reversal
Operational voltage	12 V DC
Pilot	Internal
Coil width	20 mm
Pilot valve width	22.5 mm
Duty cycle	100 %
Typ. switch-on time	12 ms
Typ. switch-off time	12 ms
Min. ambient temperature	-15 °C
Max. ambient temperature	50 °C
Min. medium temperature	-15 °C
Max. medium temperature	50 °C
Medium	Compressed air
Min. oil content of compressed air	0 mg/m ³
Max. oil content of compressed air	1 mg/m ³
Max. particle size	50 µm
Mounting on manifold strip	PRS strip
Weight	0.157 kg
Material	
Housing material	Polyoxymethylene
Seal material	Acrylonitrile butadiene rubber

Part No.

R432008665

Technical information

Versions with voltage of less than 50 V DC do not have a protective ground.

The min. control pressure must be adhered to, since otherwise faulty switching and valve failure may result!

The pressure dew point must be at least 15 °C less than ambient and medium temperature and may not exceed 3 °C.

The oil content of compressed air must remain constant during the life cycle.

Use only the approved oils from AVENTICS. Further information can be found in the "Technical information" document (available in <https://www.emerson.com/en-us/support>).

4/2-directional valve, Series 840 - inch

R432008665

Series 840

2025-07-21

Dimensions in inches

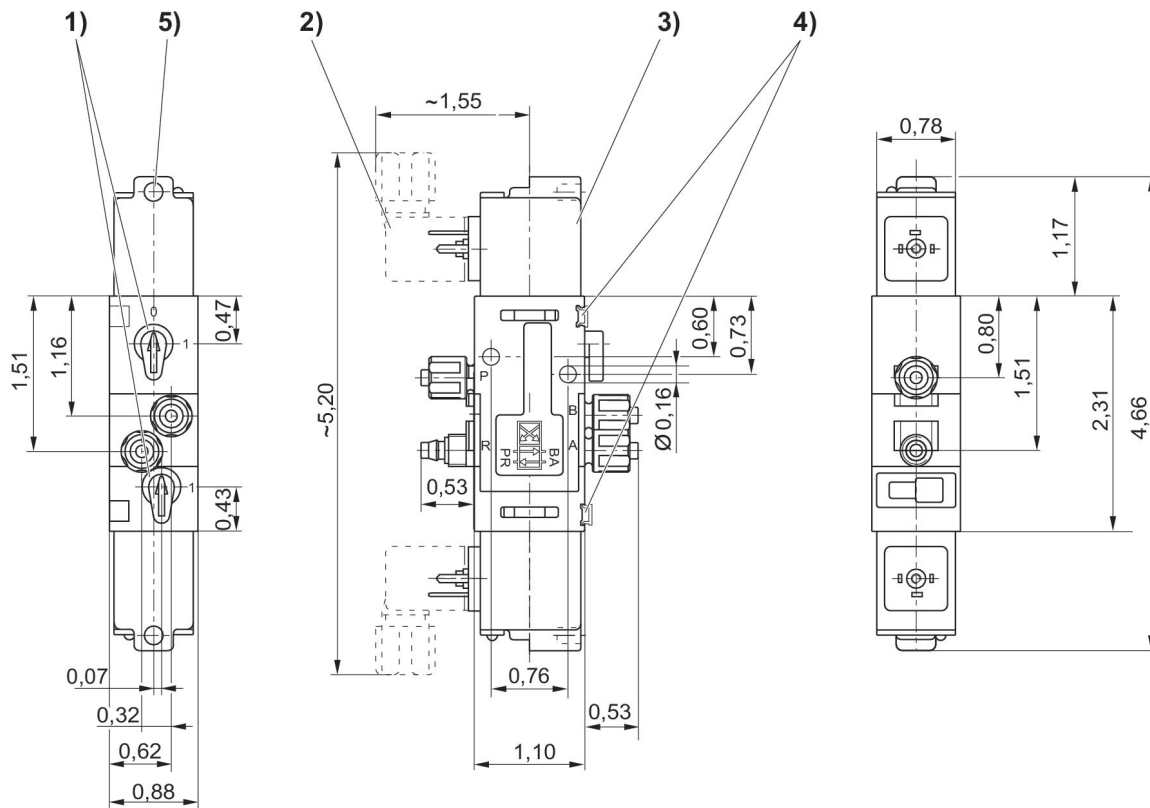

- 1) Manual override 2) Valve plug connector 3) Coil can be rotated at 180° intervals
4) Mounting space for name plate 5) Hole for M5 fitting or silencer Ø 4.5 mm