

# 3/2-directional valve, Series A-Pilotair®

## R431004537

General series information  
AVENTICS Series A-Pilotair Directional valves

- manually operated



### Technical data

Industry	Industrial
Type	2-HA-4 3 positions both handles
Activation	Manual
Nominal flow Qn	1308.72 l/min
Compressed air connection output	Ø 1/4"
Working pressure min.	0 bar
Working pressure max	13.7 bar
Sealing principle	Soft Seal
Type	Poppet valve
Type	2-HA-4
Control pressure min.	0 bar
Control pressure max.	17.2 bar
Min. ambient temperature	-40 °C
Max. ambient temperature	71 °C
Min. medium temperature	-40 °C
Max. medium temperature	71 °C
Medium	Compressed air
Oil content of compressed air min.	0 mg/m <sup>3</sup>

Oil content of compressed air max.	1 mg/m <sup>3</sup>
Max. particle size	50 µm
Compressed air connection input	Ø 1/4"
Weight	1.81 kg
Housing material	Die-cast aluminum
Part No.	R431004537

## Technical information

The 2-HA-3 and 2-HA-4 models are an extension of the 2-HA-2 models. They were created to furnish a housing that will operate up to four 3-way valves to provide a variety of functions.

These valves were designed primarily for use with multi position cylinders for Transmission Controls. They also meet the application requirements for two different supply pressures, selector functions and directional control of up to four different circuits.

It is possible to operate all four valves with a single handle or in any combination from one to three valves with the left-hand handle or with the right-hand handle.

Double handle assemblies are provided for space conservation and for applications requiring two handles located adjacent to each other. Thus, two different functions can be controlled. As an example, the left handle can control direction (forward or reverse) and the right handle, range (1st, 2nd, 3rd and 4th gear).

The min. control pressure must be adhered to, since otherwise faulty switching and valve failure may result!

The pressure dew point must be at least 15 °C less than ambient and medium temperature and may not exceed 3 °C.

The oil content of compressed air must remain constant during the life cycle.

Use only the approved oils from AVENTICS. Further information can be found in the "Technical information" document (available in <https://www.emerson.com/en-us/support>).

Dimensions in inches

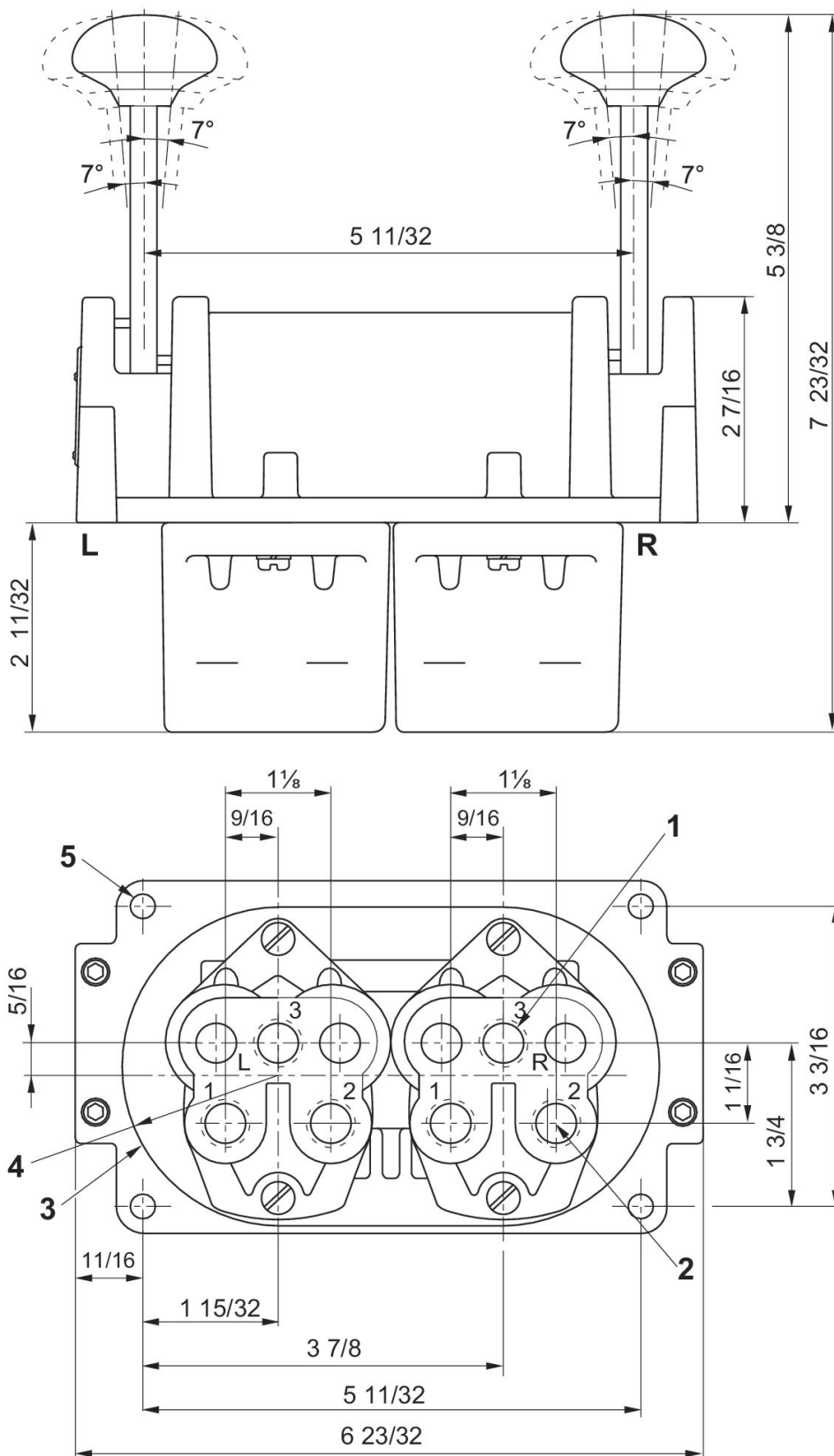

- 1) Air supply
- 2) 1/4 - 18 NPTF 6 ports
- 3) panel mounting hole

4) 1 11/16 R  
5) 9/32 NPTF 4 ports

3 positions both handles

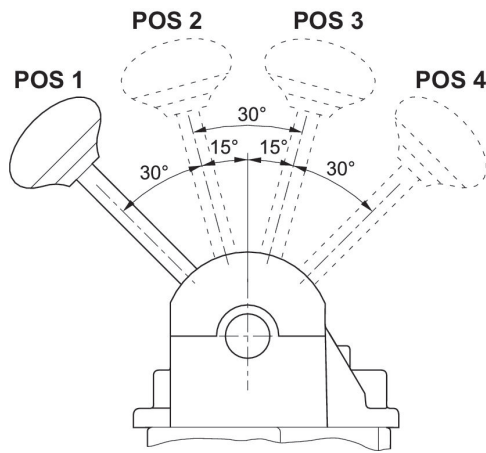

Handle position		1	2	3
Out Port Supplied	OUT port 1L			X
Out Port Supplied	OUT port 2L	X		
Out Port Supplied	OUT port 1R			X
Out Port Supplied	OUT port 2R	X		

X denotes port supplied in that position. Empty block denotes port exhausted in that position.

Handle position		1	2	3
Out Port Supplied	OUT port 1L			X
Out Port Supplied	OUT port 2L	X	X	
Out Port Supplied	OUT port 1R			X
Out Port Supplied	OUT port 2R	X		

X denotes port supplied in that position. Empty block denotes port exhausted in that position.