

3/2-directional valve, Series A-Pilotair®

R431003429

General series information
AVENTICS Series A-Pilotair Directional valves

- manually operated

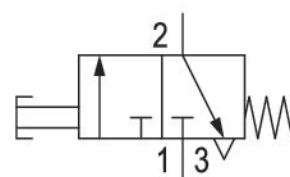

Technical data

Industry
Type

Industrial
For panel installation
manually operated
2-BA-1

Activation

Manual

Nominal flow Qn

1308.72 l/min

Version

NC

Compressed air connection output

1/4" NPTF

Working pressure min.

0 bar

Working pressure max.

13.7 bar

Sealing principle

Soft Seal

Type

Poppet valve

Control pressure min.

0 bar

Control pressure max.

17.3 bar

Min. ambient temperature

-40 °C

Max. ambient temperature	71 °C
Min. medium temperature	-40 °C
Max. medium temperature	71 °C
Medium	Compressed air
Oil content of compressed air min.	0 mg/m ³
Oil content of compressed air max.	1 mg/m ³
Max. particle size	50 µm
Compressed air connection input	1/4" NPTF
Weight	0.45 kg
Housing material	Die-cast aluminum
Surface housing	chromated
Part No.	R431003429

Technical information

The model 2-BA-1 PILOTAIR Valve is a panel mounted, 2 position button operated 3-way valve with 1/4" NPT inlet and outlet ports.

The min. control pressure must be adhered to, since otherwise faulty switching and valve failure may result!

The pressure dew point must be at least 15 °C less than ambient and medium temperature and may not exceed 3 °C.

The oil content of compressed air must remain constant during the life cycle.

Use only the approved oils from AVENTICS. Further information can be found in the "Technical information" document (available in <https://www.emerson.com/en-us/support>).

Dimensions in inches

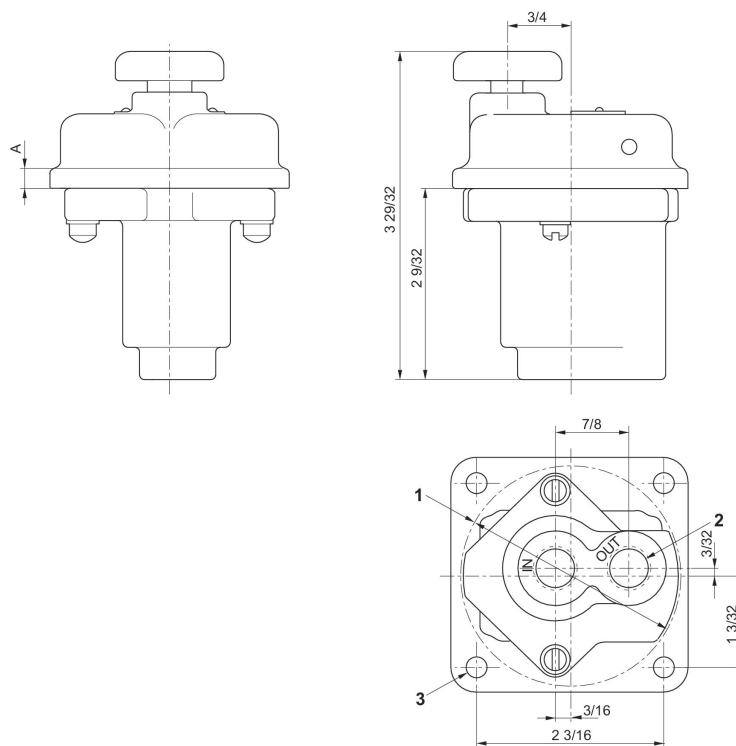

-
- 1) Mounting hole $\varnothing 2\ 9/16$
 - 2) $1/4 - 18$ NPTF 2 ports
 - 3) $9/32$ diameter (4) places ports on bottom