

AVENTICS Series HV30 Directional valves

The AVENTICS Series HV30 complies with the valve standard ISO 5599-1. Due to the level of flow and robustness, especially on high ambient temperatures, HV30 is the perfect valve for Aluminium applications.



Technical data

Industry

Industrial

Activation

Electrically

Frame size

ISO 3

Min. working pressure

2 bar

Max. working pressure

10 bar

Connector standard

CNOMO / NFE 49-003-1

Protection class with connection

IP65

Operational voltage

24 V DC

Operational voltage DC

24 V

Voltage tolerance DC

-10% / +10%

Power consumption DC

2.4 W

Duty cycle

100 %

Min. ambient temperature	10 °C
Max. ambient temperature	120 °C
Min. medium temperature	10 °C
Max. medium temperature	120 °C
Medium	Compressed air
Min. oil content of compressed air	0 mg/m ³
Max. oil content of compressed air	5 mg/m ³
Max. particle size	5 µm
Weight	0.18 kg

Material

Housing material	Polyphenylene sulfide
Seal material	Fluorocautchouc
Part No.	R424B12522

Technical information

Max. ambient temperature: +180 °C at 1 hour continuous operation and up to +200 °C at 15 hours standby operation

At an ambient temperature of over 120 °C, the duty cycle is reduced by 50%.

The min. control pressure must be adhered to, since otherwise faulty switching and valve failure may result!

The pressure dew point must be at least 15 °C less than ambient and medium temperature and may not exceed 3 °C.

The oil content of compressed air must remain constant during the life cycle.

Use only the approved oils from AVENTICS. Further information can be found in the "Technical information" document (available in <https://www.emerson.com/en-us/support>).

Pilot valve, Series HV30

2024-04-02

R424B12522

Dimensions in mm

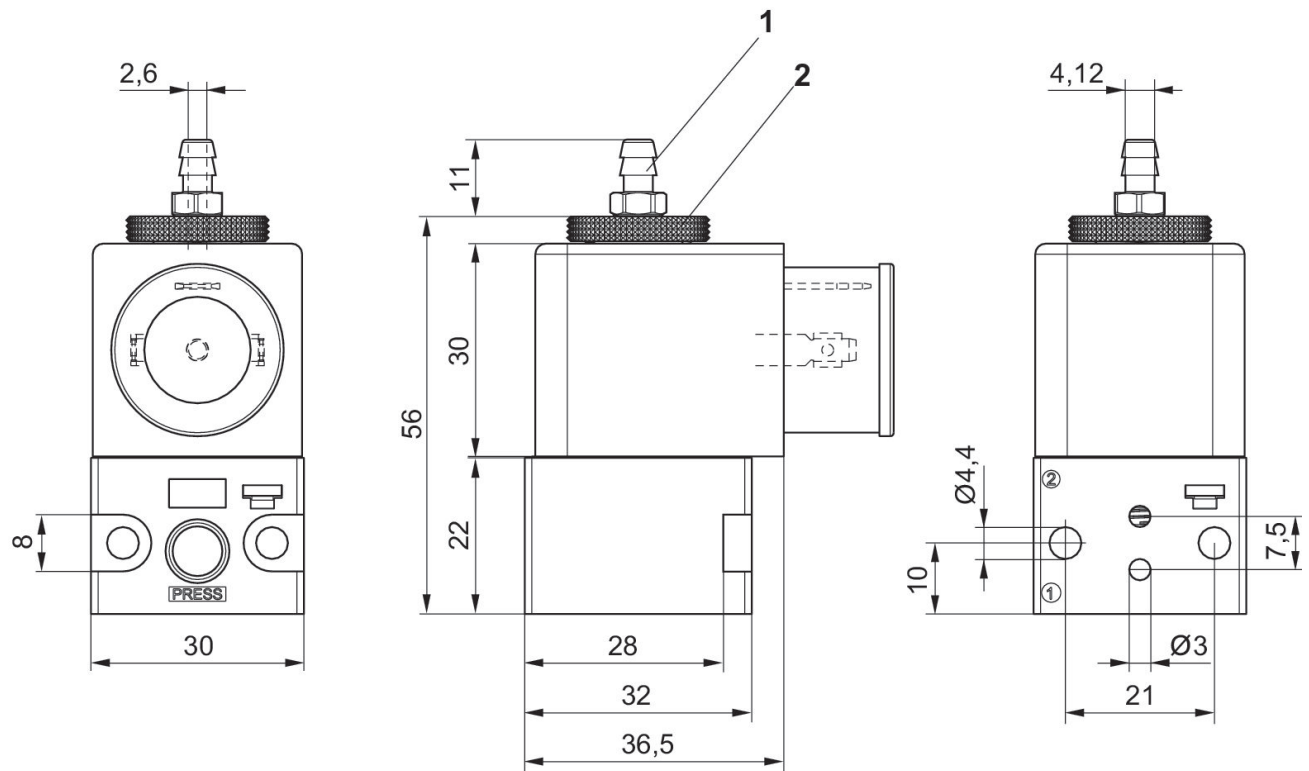

1) Tightening torque: 0.8 Nm \pm 0.01

2) Tightening torque: 0.4 Nm \pm 0.01

Scope of delivery: Pressure connection, fluoropolymer tubing $\text{Ø}6 \times 1$