

Series AV05

The AVENTICS Series AV03/AV05 provide a reliable basis for both compact handling systems and complex automation solutions. Within machine safety the Series AV03/AV05 offers intelligent solutions that significantly reduce your effort in creating a safe design. With the integration of the fieldbus and I/O-modules of the Series AES, also all requirements for distributed control are available. The Series AV03/AV05 is easy to configure, easy to use and easy to extend as well as IIoT futureproof thanks to the integration of OPC UA and the Digital Twin

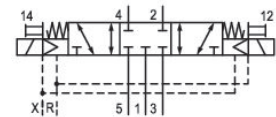

Technical data

Industry

Activation

Valve type

Switching principle

Valve function

Actuating control

Sealing principle

Connection type

Manual override

Industrial

Electrically

Spool valve, positive overlapping

5/3, closed center

Closed Center

Double Solenoid

Soft seal

Plate connection

without detent

Pilot control exhaust

With collective pilot air exhaust

Nominal flow Q_n

650 l/min

Nominal flow Q_n 1 to 2

650 l/min

Nominal flow Q_n 2 to 3

520 l/min

Flow conductance b

0.37

Flow conductance C

2.49 l/(s*bar)

Min. working pressure

-0.9 bar

5/3-directional valve, Series AV05

2024-03-19

R422103005

Max. working pressure	10 bar
Min. control pressure	3 bar
Max. control pressure	8 bar
Protection class with connection	IP65
Operational voltage	24 V DC
Operational voltage DC	24 V
Voltage tolerance DC	-10% / +10%
Pilot	External
LED status display	Yellow
Power consumption DC	0.55 W
Duty cycle	100 %
Typ. switch-on time	13 ms
Typ. switch-off time	13 ms
Blocking principle	Base plate principle, multiple
Min. ambient temperature	-10 °C
Max. ambient temperature	60 °C
Min. medium temperature	-10 °C
Max. medium temperature	60 °C
Medium	Compressed air
Min. oil content of compressed air	0 mg/m ³
Max. oil content of compressed air	5 mg/m ³
Max. particle size	40 µm
Mounting screws	Hexalobular socket (TORX) ISO 10664-8
Mounting screw tightening torque	0.5 Nm
Tightening torque tolerance	±0,1 mT
Weight	0.062 kg

Material

Housing material	Polyamide fiber-glass reinforced
Seal material	Acrylonitrile butadiene rubber Hydrogenated acrylonitrile butadiene rubber
Material end plate	Polyamide fiber-glass reinforced
Part No.	R422103005

Technical information

The pilot type (external/internal) is not implemented in the valve, but in the end plate of the valve system.

The min. control pressure must be adhered to, since otherwise faulty switching and valve failure may result!

The pressure dew point must be at least 15 °C less than ambient and medium temperature and may not exceed 3 °C.

The oil content of compressed air must remain constant during the life cycle.

Use only the approved oils from AVENTICS. Further information can be found in the "Technical information" document (available in <https://www.emerson.com/en-us/support>).

5/3-directional valve, Series AV05

2024-03-19

R422103005

Dimensions

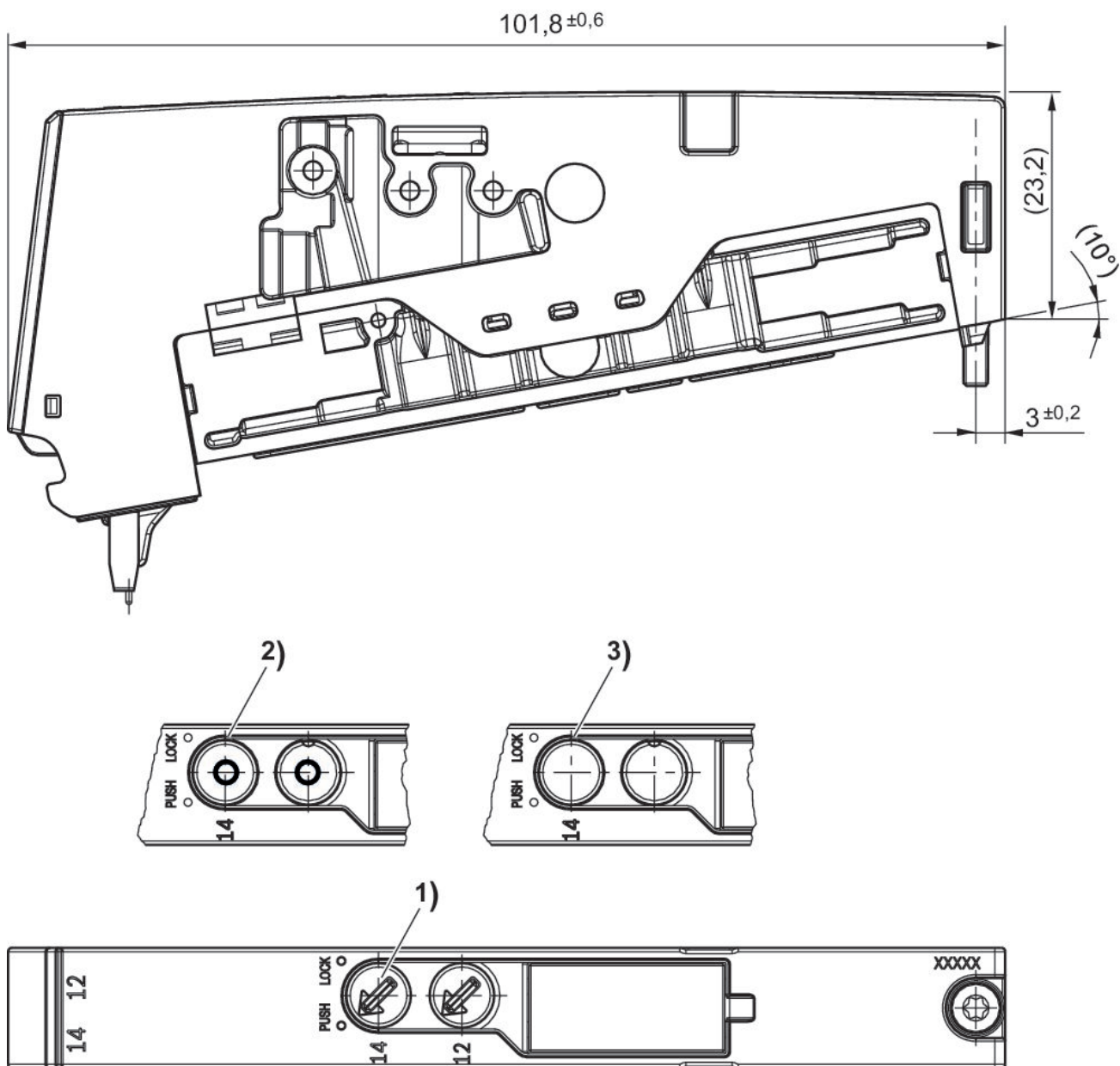

- 1) Manual override: with detent
- 2) manual override: without detent
- 3) Manual override: without detent