

# 2x3/2-directional valve, Series TC08

R422102051

Series  
TC08

2024-05-14

## AVENTICS Series TC08 Directional valves

The AVENTICS Series TC08/TC15 includes a wide range of spool valves with housings made of high-performance polymers with robust and flexible metal inserts. It is designed for flow rate performances from 800 to 1500 l/min. These directional valves are easy to assemble, making them ideal for applications requiring the highest efficiency in limited spaces.

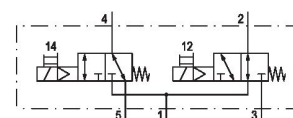

## Technical data

Industry

Activation

Valve type

Switching principle

Valve function

Actuating control

Sealing principle

Connection type

Manual override

Industrial

Electrically

Spool valve, positive overlapping

2x 3/2 NC/NO, with spring return

NC/NO

Double Solenoid

Soft seal

Pipe connection

without detent

Standard compressed air connection

Compressed air connection input

Compressed air connection output

Compressed air connection, exhaust

according to ISO 228-1

G 1/8

G 1/8

G 1/8

Nominal flow Qn

Flow conductance b

Flow conductance C

600 l/min

0.27

2.8 l/(s\*bar)

# 2x3/2-directional valve, Series TC08

R422102051

Series  
TC08

2024-05-14

Min. working pressure	3 bar
Max. working pressure	10 bar
Min. control pressure	3 bar
Max. control pressure	10 bar
Electrical connection type	Plug
Electrical connection size	M8
Electrical connection number of poles	4-pin
Connector standard	DIN EN 60947-5-2
Protection class acc. to DIN EN 61140	Class III
Protection class with connection	IP65
Operational voltage	24 V DC
Operational voltage DC	24 V
Voltage tolerance DC	-10% / +10%
Pilot	External Internal
Coil width	15.6 mm
Pilot valve width	15 mm
LED status display	Yellow
Power consumption DC	2.2 W
Nominal resistance	280 Ω
Duty cycle	100 %
Typ. switch-on time	10 ms
Typ. switch-off time	14 ms
Min. ambient temperature	-10 °C
Max. ambient temperature	50 °C
Min. medium temperature	-10 °C
Max. medium temperature	50 °C
Medium	Compressed air
Min. oil content of compressed air	0 mg/m <sup>3</sup>
Max. oil content of compressed air	5 mg/m <sup>3</sup>
Max. particle size	5 μm
Mounting on manifold strip	P-strip
Mounting screw tightening torque	2 Nm
Tightening torque tolerance	±0,2 mT
Weight	0.182 kg

# 2x3/2-directional valve, Series TC08

R422102051

Series  
TC08

2024-05-14

---

## Material

Housing material	Polyamide fiber-glass reinforced
Seal material	Acrylonitrile butadiene rubber Polyurethane
Material threaded bushing	Brass Die cast zinc
Material front plate	Polyamide fiber-glass reinforced
Part No.	R422102051

## Technical information

The min. control pressure must be adhered to, since otherwise faulty switching and valve failure may result!

The pressure dew point must be at least 15 °C less than ambient and medium temperature and may not exceed 3 °C.

The oil content of compressed air must remain constant during the life cycle.

Use only the approved oils from AVENTICS. Further information can be found in the "Technical information" document (available in <https://www.emerson.com/en-us/support>).

# 2x3/2-directional valve, Series TC08

R422102051

Series  
TC08

2024-05-14

## Dimensions

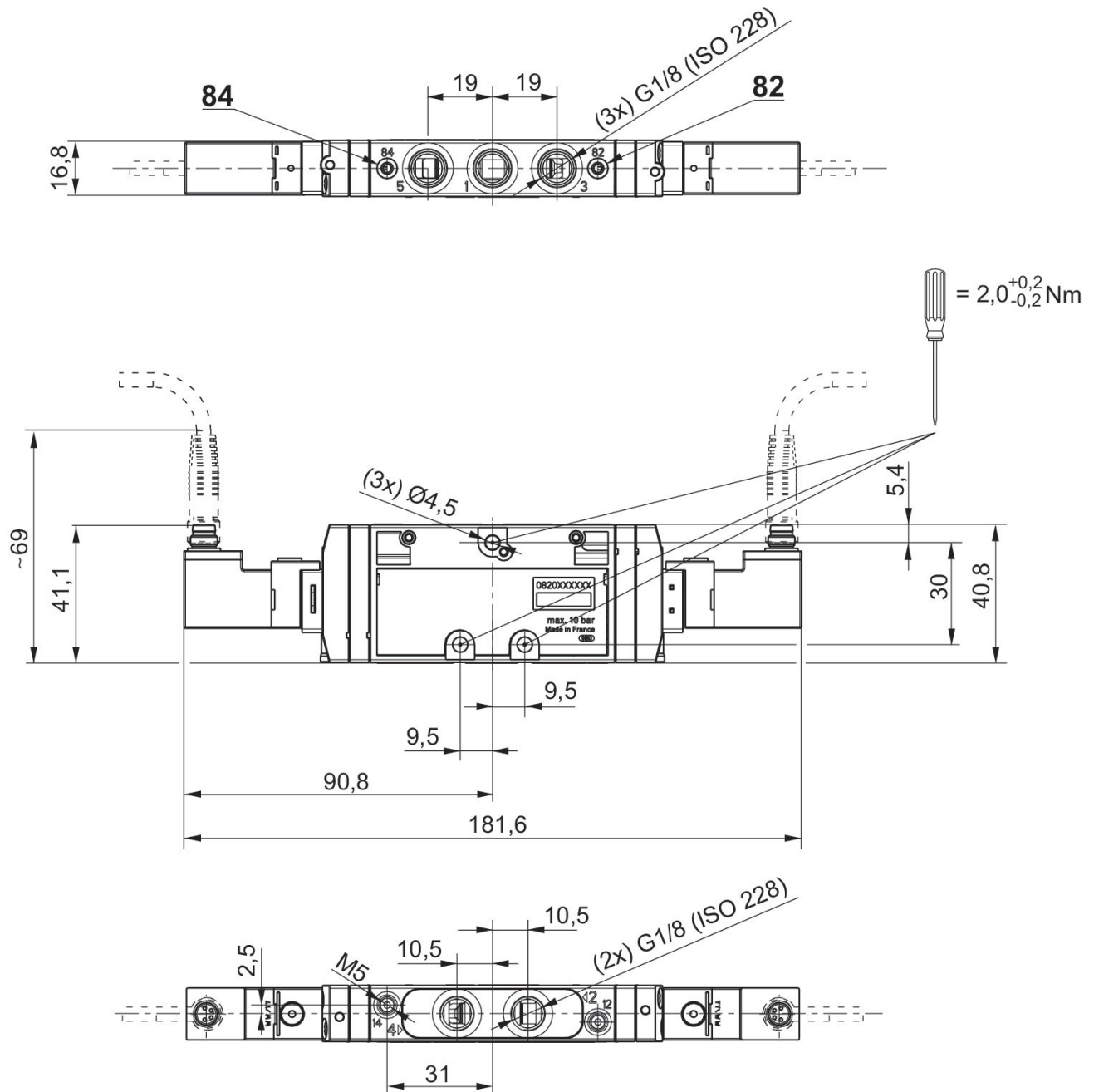

# 2x3/2-directional valve, Series TC08

R422102051

Series  
TC08

2024-05-14

PIN assignment and cable colors for  
valve plug connectors

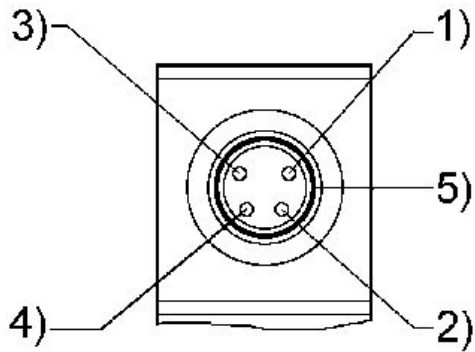

PIN assignment: 1) PIN not assigned 2) PIN not assigned 3) 0 V 4) 24 V 5)  
LED Cable colors 1) Brown 2) White 3) Blue 4) Black