

5/2 directional valve, series LS04-PD

2024-04-22

R422005155

Series LS04

Qn max. [[310] l/min]

2x3/2, 5/2, 5/3 spool valves with plastic housing

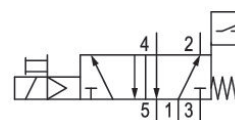

Technical data

Industry

Industrial

Activation

Electrically

Note

with position detection

Valve type

Spool valve, positive overlapping

Switching principle

5/2, with spring return

Actuating control

Single Solenoid

Sealing principle

Soft seal

Connection type

Pipe connection

Manual override

without detent

Compressed air connection input

Ø 6

Compressed air connection output

Ø 6

Compressed air connection, exhaust

Ø 6

Nominal flow Qn

310 l/min

Flow conductance b

0.27

Flow conductance C

1.5 l/(s*bar)

Min. working pressure

3 bar

5/2 directional valve, series LS04-PD

2024-04-22

R422005155

Max. working pressure	7 bar
Electrical connection size	M8
Electrical connection number of poles	3-pin
Connector standard	DIN EN 60947-5-2
Protection class acc. to DIN EN 61140	Class III
Protection class with connection	IP65
Protective circuit	Z-diode
Operational voltage	24 V DC
Operational voltage DC	24 V
Voltage tolerance DC	-10% / +10%
Pilot	Internal
LED status display	Yellow
Power consumption DC	1.3 W
Typ. switch-on time	10 ms
Typ. switch-off time	22 ms
Generic emission standard in accordance with	EN 61000-6-4:2002
Generic immunity standard in accordance with	IEC 61000-6-2:2005
Min. ambient temperature	-10 °C
Max. ambient temperature	50 °C
Min. medium temperature	-10 °C
Max. medium temperature	50 °C
Medium	Compressed air
Min. oil content of compressed air	0 mg/m ³
Max. oil content of compressed air	5 mg/m ³
Max. particle size	5 µm
Mounting screws	M3
Mounting screw tightening torque	0.5 Nm
Weight	0.053 kg
Type sensor	electronic PNP, with LED
Sensor port size	M8
Sensor number of poles	3-pin
Material	
Housing material	Polyoxymethylene

5/2 directional valve, series LS04-PD

2024-04-22

R422005155

Seal material

Acrylonitrile butadiene rubber
Hydrogenated nitrile butadiene rubber
Polyurethane

Part No.

R422005155

Technical information

A duty cycle of 100% is only valid for valves mounted separately.

If the solenoid valve is switched off, the flow direction is from connection 4 to 5, 1 to 2. The sensor output signal is high and the red LED is illuminated. The maximum sensor current is 12 mA.

The min. control pressure must be adhered to, since otherwise faulty switching and valve failure may result!

The pressure dew point must be at least 15 °C less than ambient and medium temperature and may not exceed 3 °C.

The oil content of compressed air must remain constant during the life cycle.

Use only the approved oils from AVENTICS. Further information can be found in the "Technical information" document (available in <https://www.emerson.com/en-us/support>).

5/2 directional valve, series LS04-PD

2024-04-22

R422005155

Dimensions

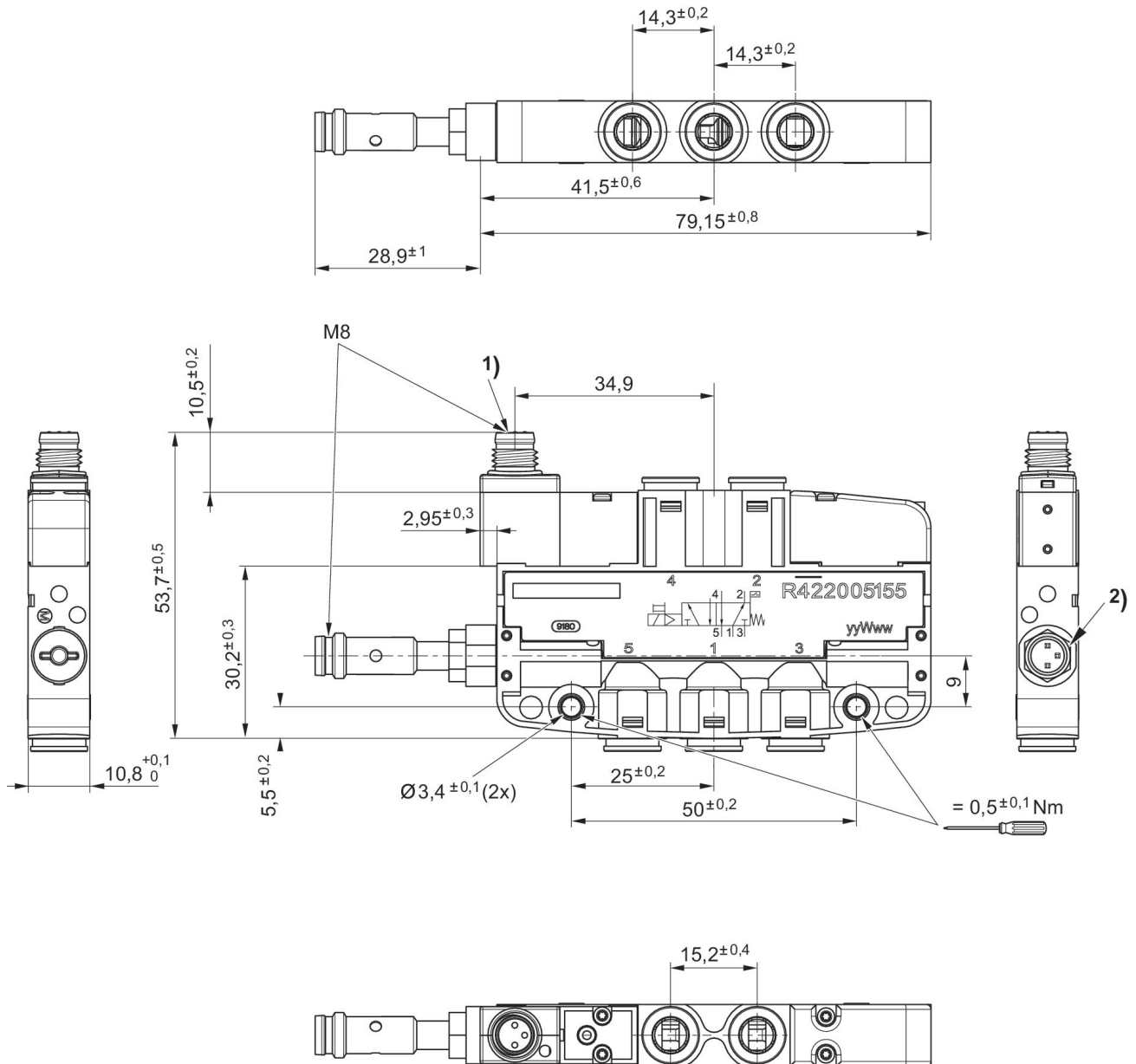

- 1) Valve plug connector M8
- 2) Sensor plug M8, 3-pin

5/2 directional valve, series LS04-PD

2024-04-22

R422005155

PIN assignment sensor, plug M8

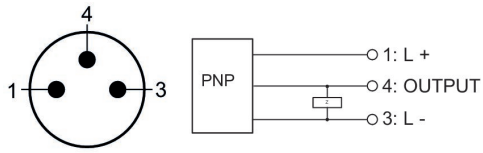

PIN assignment for valve plug connectors 3-pin

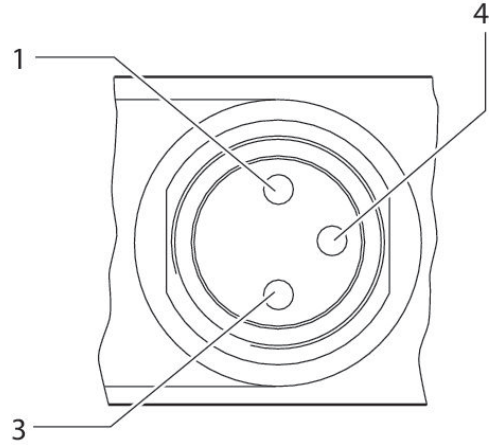

1) Pin not assigned 3) 0 V 4) 24 V Note: Bi-polar protective circuit to prevent overvoltage