

Series EV12

The AVENTICS EV18 high flow proportional pressure valves with digital control are highly efficient and ideal for pressure regulation requirements. It offers a small footprint and easy-to-use modular design. These high flow pressure regulators can be directly integrated on the Series AS air preparation unit, increasing efficiency with one compact and complete IIoT solution from one supplier, or they can be used as a standalone proportional pressure regulator with high flow capabilities.

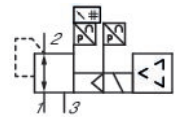

Technical data

Type	Pressure supply, left
Control	Display: display
Function	Externally piloted
Air supply	Pressure-holding, output 10V constant to supply a set point potentiometer.
Min. regulation range	left
Max. regulation range	0 bar
Min. working pressure	10 bar
Max. working pressure	0 bar
Hysteresis	10 bar
Nominal flow Qn	0,12 bar
Min. ambient temperature	16500 l/min
Max. ambient temperature	0 °C
Min. medium temperature	50 °C
Max. medium temperature	0 °C
Operational voltage DC	50 °C
Max. current consumption	24 V
Permissible ripple	220 mA
Max. particle size	5%
	50 µm

E/P pressure regulator, Series EV18

2024-02-20

R414011413

Min. oil content of compressed air	0 mg/m ³
Max. oil content of compressed air	5 mg/m ³
Frame size	AS5
Type	Poppet valve
Compressed air connection input	G 1
Compressed air connection output	G 1
Electrical connection size	M12
Electrical connection number of poles	5-pin
Electrical connection coding	A-coded
Industry	Industrial
Weight	2.15 kg

Material

Housing material	Polyamide
Seal material	Nitrile butadiene rubber
Material base plate	Aluminum
Part No.	R414011413

Technical information

Power outage: maintain pressure

The min. control pressure must be adhered to, since otherwise faulty switching and valve failure may result!

The pressure dew point must be at least 15 °C less than ambient and medium temperature and may not exceed 3 °C.

The oil content of compressed air must remain constant during the life cycle.

Use only the approved oils from AVENTICS. Further information can be found in the "Technical information" document (available in <https://www.emerson.com/en-us/support>).

Dimensions

E/P pressure regulator, Series EV18

2024-02-20

R414011413

Pressure supply, left

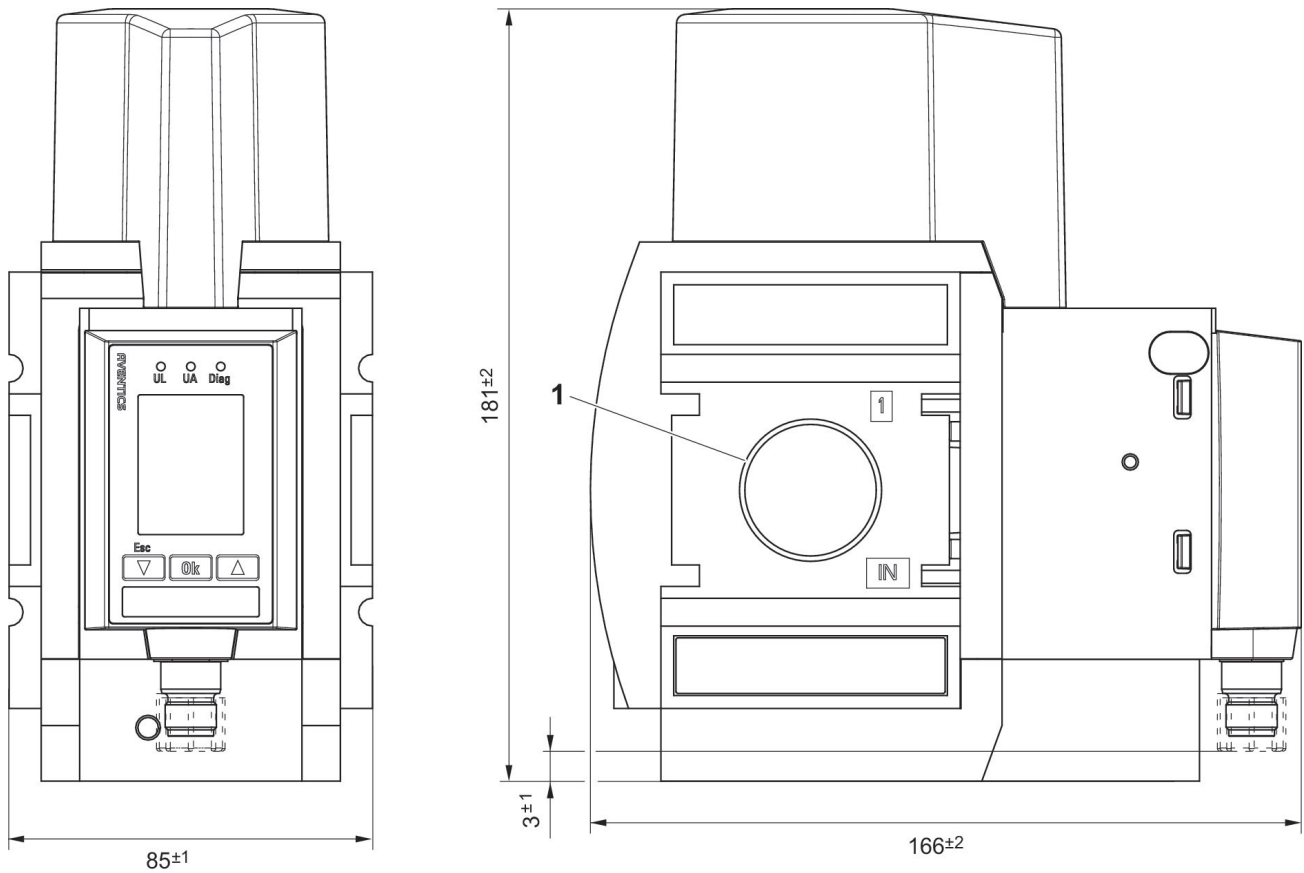

1) Connection thread

E/P pressure regulator, Series EV18

2024-02-20

R414011413

Pressure supply, left

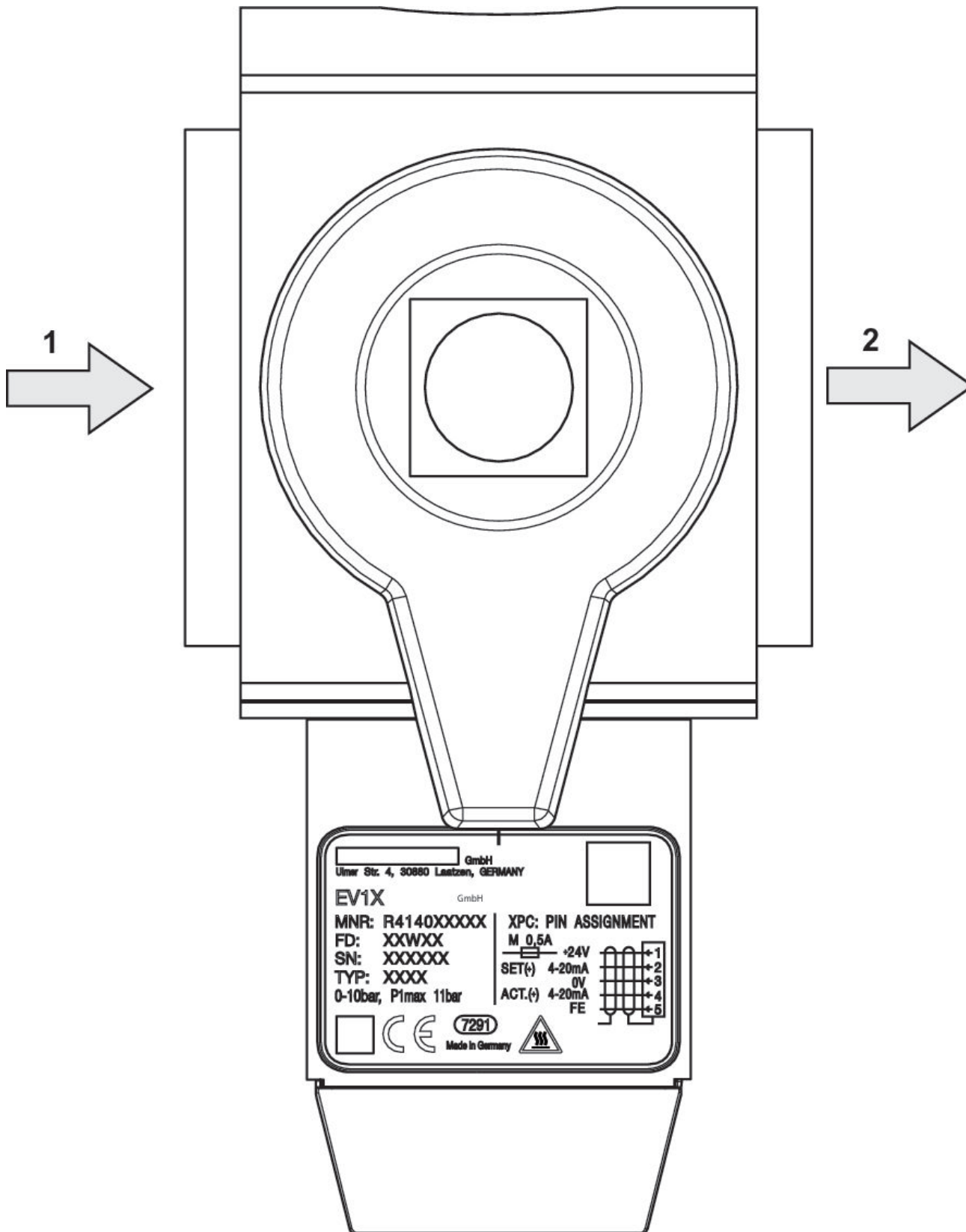

R414011413

Flow characteristic curve

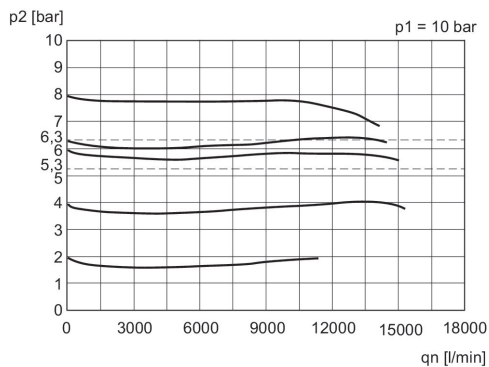

p1 = Working pressure p2 = Secondary pressure qn = Nominal flow

Characteristic curve and plug assignment for IO-Link version

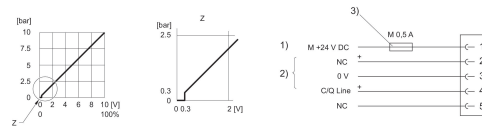

- 1) power supply
- 2) C/Q Line (pin 4) Not connected (NC) (pin 2) are related to 0 V (pin 3).
- 3) The power supply must be protected by an external M 0.5 A fuse. Connect the plug via a shielded cable to ensure EMC.

Characteristic and pin assignment for voltage control with actual output value

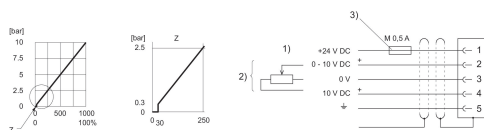

- 1) power supply
- 2) Actual value (pin 4) and nominal value (pin 2) are related to 0 V (pin 3). Nominal input value ($R = 1 \text{ M}\Omega$), actual output value: min. load resistance $> 10 \text{ K}\Omega$. If the power supply is switched off, the nominal input value is high-ohmic.
- 3) The power supply must be protected by an external M 0.5 A fuse. Connect the plug via a shielded cable to ensure EMC.

Characteristic and pin assignment for current control with actual output value

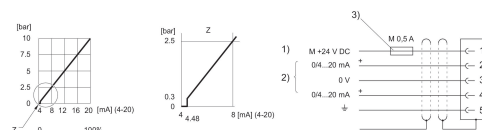

- 1) power supply
- 2) Actual value (pin 4) and nominal value (pin 2) are related to 0 V (pin 3). Nominal input value (ohmic load 100Ω), actual output value: external ohmic load $< 300 \Omega$. If the power supply is switched off, the nominal input value is high-ohmic.
- 3) The power supply must be protected by an external M 0.5 A fuse. Connect the plug via a shielded cable to ensure EMC.

Functional diagram IO-Link

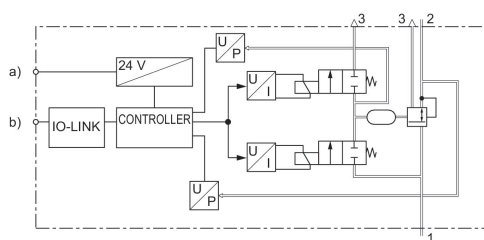

- a) Supply Voltage
- b) C/Q Line

Functional diagram

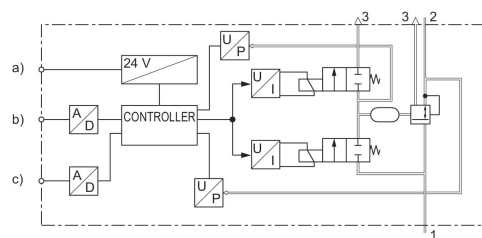

- a) Voltage supply
- b) Nominal value
- c) Actual output value

Plug assignment

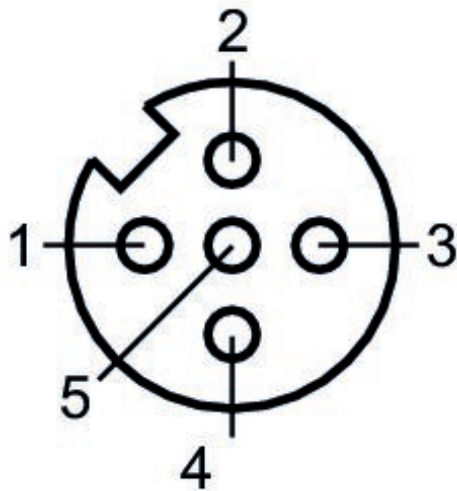

-
- 1) 24 V DC
 - 2) Nominal input value
 - 3) GND
 - 4) Actual output value
 - 5) Ground