

R414000691

AVENTICS ED07 Dynamic Direct Acting Pressure Regulator

The AVENTICS Series ED07 offers proportional pressurization and the exhaust valves are controlled separately to deliver dynamic control for the most demanding applications.

Highly dynamic proportional pressure regulator

Stackable with base plate

Nominal width 7

Flow 1300 l/min

Pressure range -1 ... 20 bar

EtherCAT, AES fieldbus connection

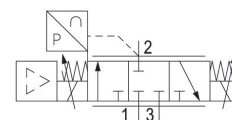
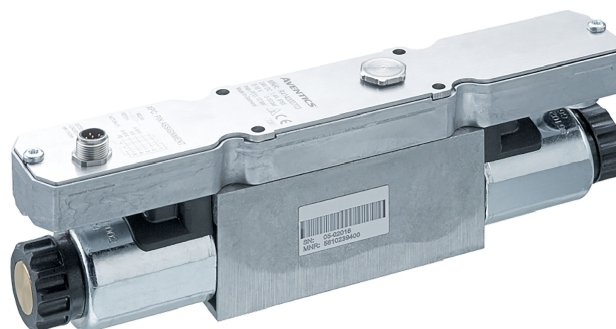

Technical data

| | |
|--------------------------|---------------------|
| Control | Directly controlled |
| Control | Analog |
| Function | Air exhaust |
| Actual output value | Analog |
| Min. regulation range | 0 bar |
| Max. regulation range | 6 bar |
| Min. working pressure | 0.5 bar |
| Max. working pressure | 8 bar |
| Hysteresis | < 0,03 bar |
| Medium | Compressed air |
| Nominal flow Qn | 1300 l/min |
| Min. ambient temperature | 5 °C |
| Max. ambient temperature | 50 °C |
| Min. medium temperature | 5 °C |
| Max. medium temperature | 50 °C |
| Operational voltage DC | 24 V |
| Max. current consumption | 1400 mA |
| Protection class | IP65 |
| Permissible ripple | 5% |

R414000691

| | |
|------------------------------------|--|
| Max. particle size | 50 µm |
| Min. oil content of compressed air | 0 mg/m ³ |
| Max. oil content of compressed air | 1 mg/m ³ |
| Type | Poppet valve |
| Mounting orientation | $\alpha = 0 \dots 90^\circ \pm \beta = 0 \dots 90^\circ$ |
| Certificates | CE declaration of conformity |
| Electrical connection size | via signal connection |
| Signal connection | input and output |
| Signal connection | Plug |
| Signal connection | M12 |
| Signal connection | 5-pin |
| Actual output value | 4 ... 20 mA |
| Nominal input value | 4 ... 20 mA |
| Industry | Industrial |
| Weight | 2.05 kg |

Material

| | |
|------------------|---|
| Housing material | Die-cast aluminum Steel, chrome-plated |
| Seal material | Hydrogenated acrylonitrile butadiene rubber |
| Part No. | R414000691 |

Technical information

With oil-free, dry air, other installation positions are possible on request.

The protection class is only ensured when the plug is mounted properly. For detailed information, see operating instructions.

The min. control pressure must be adhered to, since otherwise faulty switching and valve failure may result!

The pressure dew point must be at least 15 °C less than ambient and medium temperature and may not exceed 3 °C.

The oil content of compressed air must remain constant during the life cycle.

Use only the approved oils from AVENTICS. Further information can be found in the "Technical information" document (available in <https://www.emerson.com/en-us/support>).

Mounting orientation

$$\beta = \pm 0 \dots 90^\circ$$

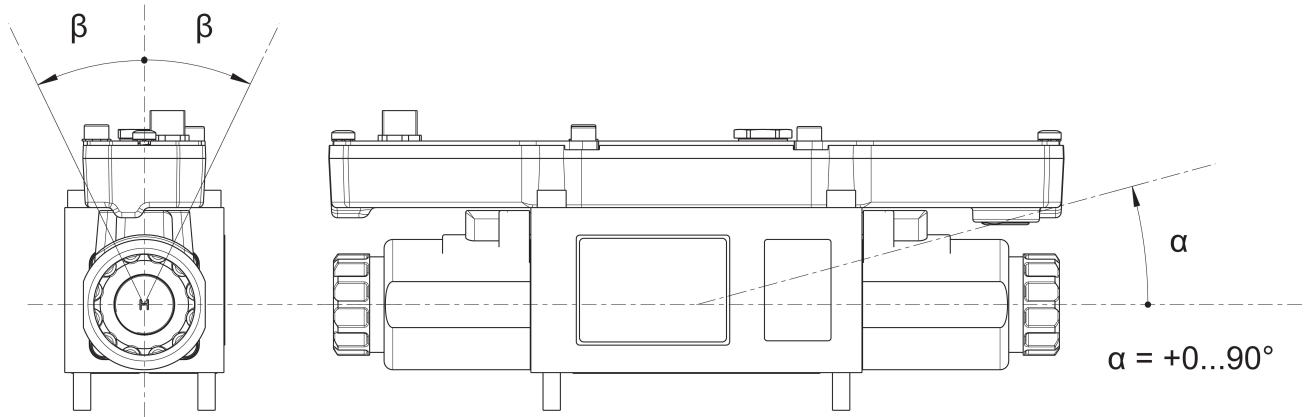

E/P pressure regulator, Series ED07

2024-02-20

R414000691

Dimensions

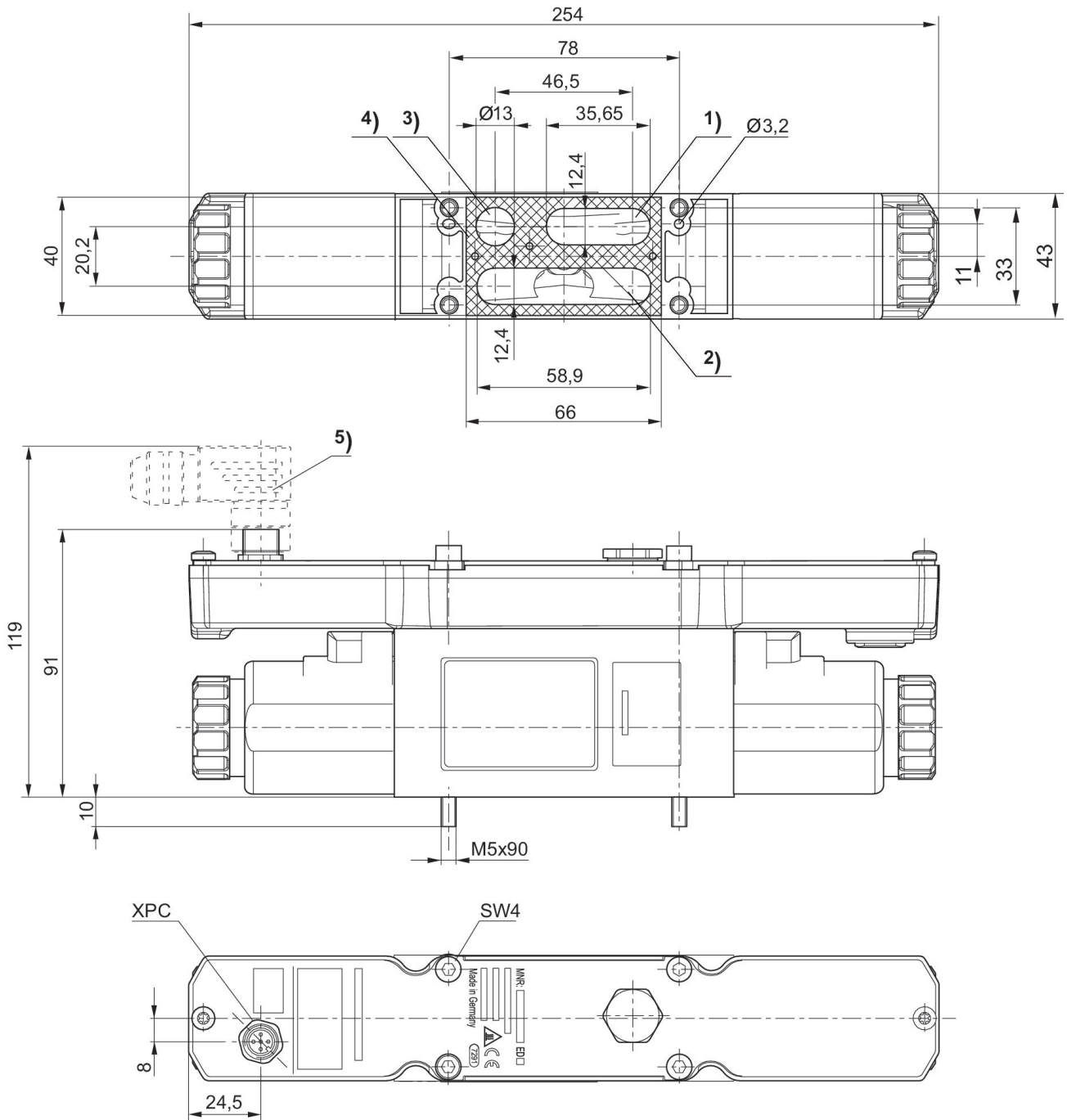

- 1) Operating pressure
- 2) Working pressure
- 3) Exhaust
- 4) Flat gasket
- 5) Accessories not supplied

R414000691

Flow diagram

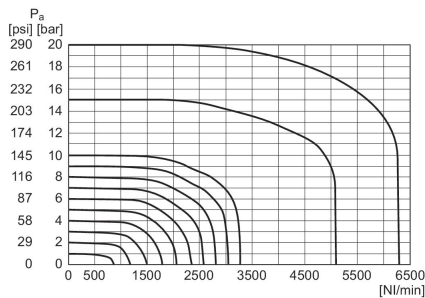

Pa = Working pressure

Characteristic and pin assignment for current control with actual output value

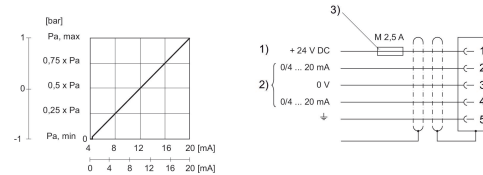

- 1) Supply Voltage
- 2) Actual value (pin 4) and nominal value (pin 2) are related to 0 V (control voltage). Nominal input value current (ohmic load 100 Ω). Actual output value (max. total resistance of downstream devices < 300 Ω).
- 3) The operating voltage must be protected by an external M 2.5 A fuse. Connect the plug via a shielded cable to ensure EMC.

Characteristic and pin assignment for voltage control with actual output value

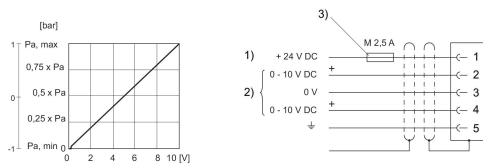

- 1) Supply Voltage
- 2) Actual value (pin 4) and target value (pin 2) are related to 0 V. If the supply voltage is switched off, the voltage input value is high-ohmic. Input resistance under supply voltage: 1 MΩ Voltage output (actual value): external working resistance 10 kΩ 3) The operating voltage must be protected by an external M 2.5 A fuse. Connect the plug via a shielded cable to ensure EMC.

Characteristic and pin assignment for potentiometer control without actual output value

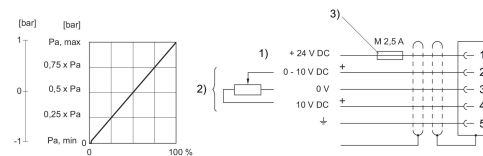

- 1) Supply Voltage
- 2) Actual value (pin 2) is related to 0 V. If the supply voltage is switched off, the voltage input value is high-ohmic. Input resistance under supply voltage: 1 MΩ 3) The operating voltage must be protected by an external M 2.5 A fuse. Connect the plug via a shielded cable to ensure EMC.

Functional diagram

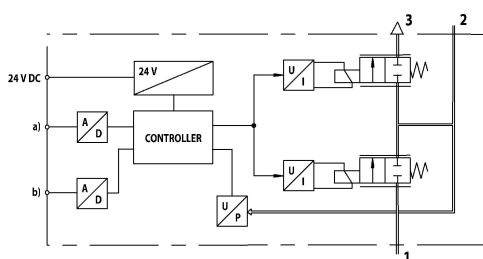

- a) Nominal input value b) Actual output value The E/P pressure control valve modulates the pressure corresponding to an analog electrical nominal input value.
- 1) Operating pressure
 - 2) Working pressure
 - 3) Exhaust