

5/2 directional safety valve, Series SV03

R412027215

General series information
AVENTICS Series SV01/03/05 Safety valves

- The AVENTICS Series SV01/03/05 double valves are redundant 3/2 and 5/2 valves for external monitoring that are designed to meet the needs and requirements of safe air supply and exhaust 3/2 valves and safe cylinder return 5/2 valves applications for machinery with pneumatic controls according to the requirements of ISO 13849-1-2 for safety functions.
- According to ISO 13849-1, Cat. 4, PL e

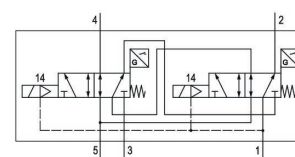
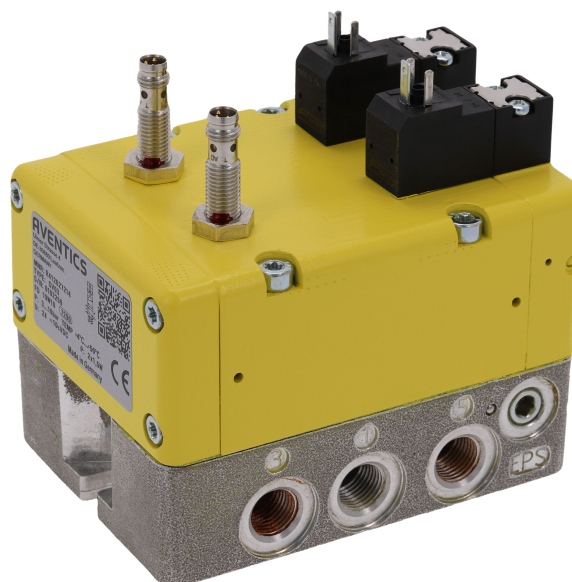

Technical data

Industry	Industrial
Activation	Electrically
Switching principle	5/2
Compressed air connection output	1/4 NPT
DC operating voltage	24 V
Voltage tolerance DC	-10% / +10%
Actuating control	Single Solenoid
Sealing principle	soft seal
Pilot	Internal
Standards	ISO 13849-1, category 4, performance level: e (possible)
Valve type	Double spool valve
Return	With spring return
Compressed air connection input	1/4 NPT
Power consumption DC	1.5 W
Working pressure min. internal	3 bar

Working pressure max. internal	10 bar
Working pressure min. external	0 bar
Working pressure max. external	10 bar
Min. ambient temperature	4 °C
Max. ambient temperature	50 °C
Min. medium temperature	4 °C
Max. medium temperature	50 °C
Medium	Compressed air
Max. particle size	5 µm
Oil content of compressed air min.	0 mg/m ³
Oil content of compressed air max.	5 mg/m ³
Connector standard	EN 175301-803, form C
Nominal flow Qn 1 to 2	1300 l/min
Nominal flow Qn 1 to 4	990 l/min
Nominal flow Qn 2 to 3	900 l/min
Nominal flow Qn 4 to 5	1160 l/min
Protection class with connection	IP65
Duty cycle	100 %
Typ. switch-on time	35 ms
Typ. switch-off time	80 ms
Max. current consumption	23 mA
Type sensor	PNP
Electrical connection for sensor	Plug
Sensor port size	M8
Sensor number of poles	3-pin
Weight	1.64 kg
Housing material	Die-cast aluminum
Seal material	Acrylonitrile butadiene rubber
Part No.	R412027215

Technical information

silencer (not included in scope of delivery)

The min. control pressure must be adhered to, since otherwise faulty switching and valve failure may result!

The pressure dew point must be at least 15 °C less than ambient and medium temperature and may not exceed 3 °C.

The oil content of compressed air must remain constant during the life cycle.

Use only the approved oils from AVENTICS. Further information can be found in the “Technical information” document (available in <https://www.emerson.com/en-us/support>).

Directional safety valve series SV is delivered and configured for internal control pressure. It can easily be converted to external control pressure. Please refer to the operating instructions. The control pressure must be > 3 bar.

Safe air supply and cylinder return via 5/2 directional valve

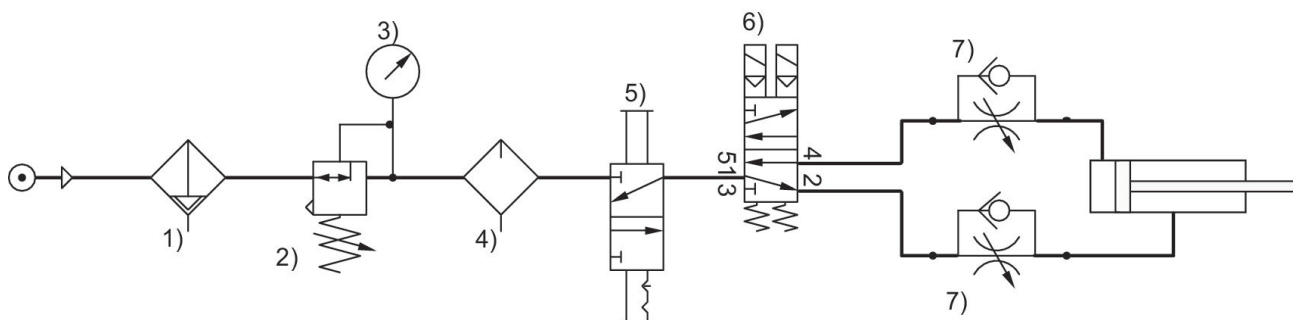

1) Filter 2) Pressure regulator 3) Pressure gauge 4) Lubricator 5) Lockout valve 6) Safety valve, Series SV 7) Check-choke valve

Dimensions

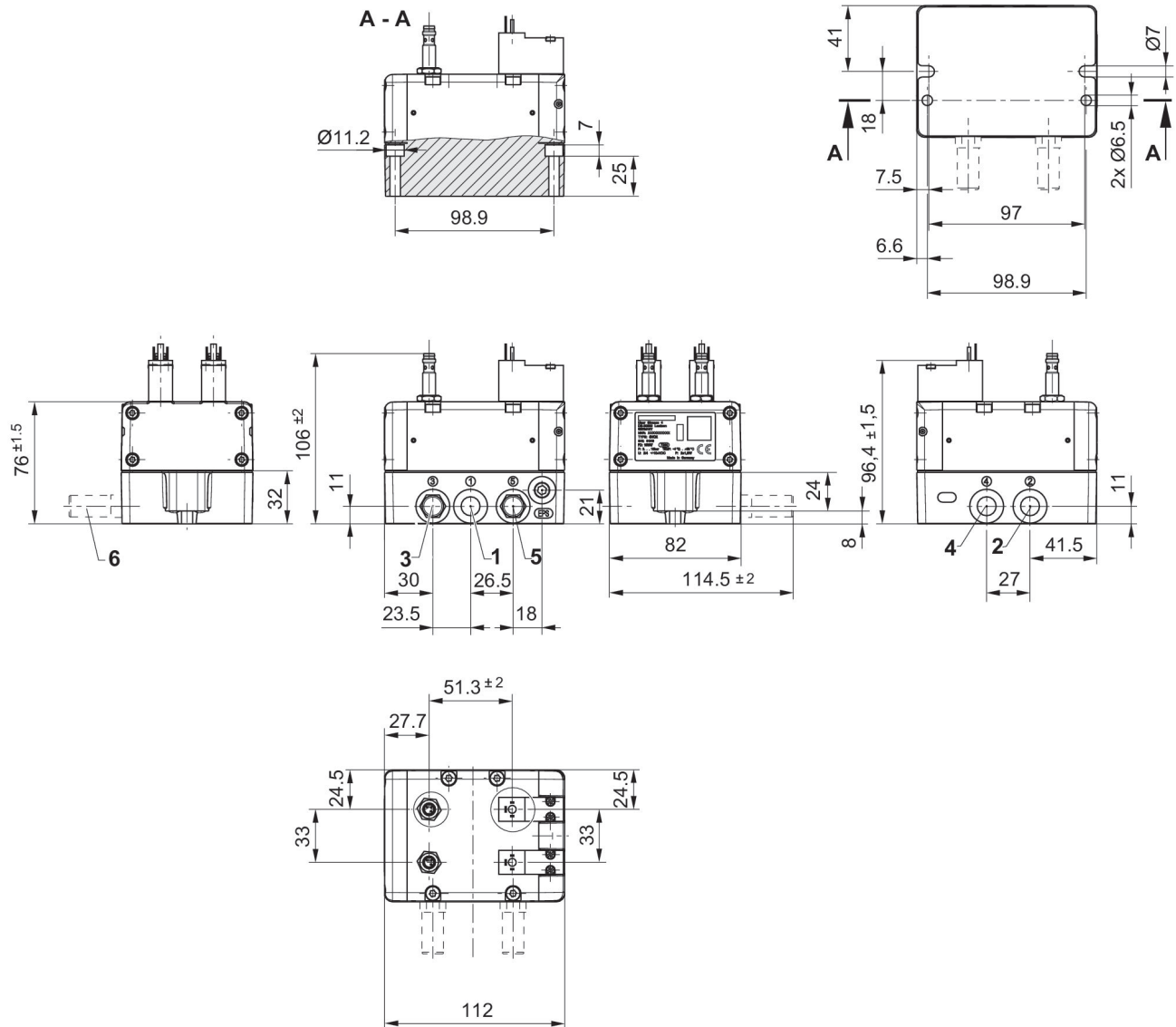

- 1) Port 1 (Input)
- 2) Port 2 (Output)
- 3) Port 3 (Exhaust)
- 4) Port 4 (Output)
- 5) Port 5 (Exhaust)
- 6) silencer (not included in scope of delivery)

Valve plug connector form C

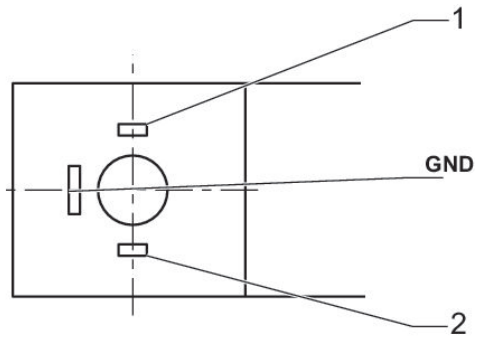

- 1) + 24 / 0 VDC
- 2) 0 / + 24 VDC

PIN assignment sensor, plug M8 3-pin

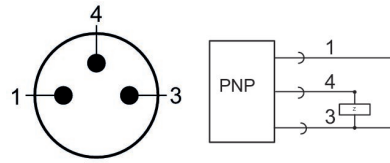

- 1) + 20 ... + 28 VDC
- 3) 0 VDC
- 4) OUT