

AVENTICS Ausgleichskupplungen



Technische Daten

Branche

Industrie

Für Serie

zum Anbau an Zylinder PRA, TRB, CCL-IS/-IC, CCI, SSI, MNI, KPZ, KHZ, 167, CVI, RPC, RDC, ITS

sphärisch

Für Serie

PRA

TRB

CCL-IS

CCL-IC

CCI

SSI

KPZ

167

CVI

RPC

Gewindegröße

M10x1,25

Gewicht

0.21 kg

Werkstoff

Werkstoff Gehäuse

Stahl, verchromt

Oberfläche Gehäuse

verzinkt

Materialnummer

R412026142

Abmessungen

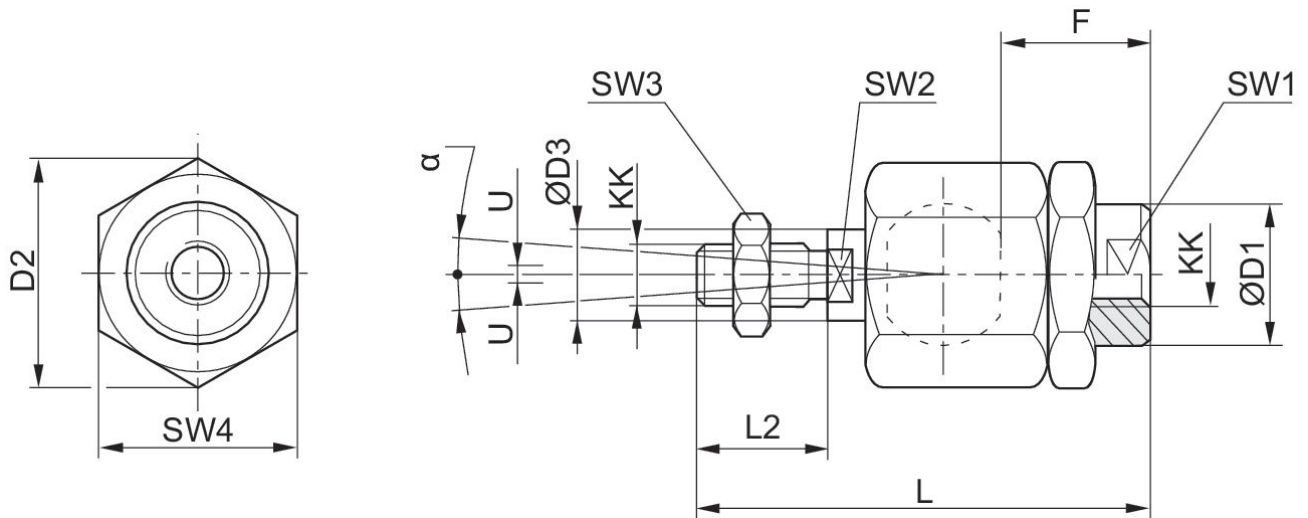

* Radialausgleich

| Materialnummer | KK | Ø D1 | D2 | Ø D3 | F | L ±2 | L2 | SW1 | SW2 |
|----------------|----------|------|------|------|----|------|------|-----|-----|
| 1826409008 | M4 | 12 | 13.5 | 4 | 13 | 33 | 8 | 12 | 3.2 |
| R412007860 | M5 | 8.5 | 14.8 | 6 | 12 | 38.5 | 13.5 | 7 | 5 |
| R412026140 | M6x1 | 8.5 | 14.5 | 6 | 11 | 36.5 | 11 | 7 | 5 |
| R412026141 | M8x1.25 | 12.5 | 19 | 8 | 21 | 58 | 21 | 11 | 7 |
| R412026142 | M10x1.25 | 22 | 32 | 14 | 23 | 74.5 | 23 | 19 | 12 |
| R412026143 | M12x1.25 | 22 | 32 | 14 | 24 | 75 | 24 | 19 | 12 |
| R412026144 | M16x1.5 | 32 | 45 | 22 | 30 | 103 | 30 | 30 | 20 |
| R412026145 | M20x1.5 | 32 | 45 | 22 | 40 | 119 | 40 | 30 | 20 |
| 1826409006 | M27x2 | 62 | 62 | 28 | 48 | 147 | 54 | 32 | 24 |
| 1826409007 | M36x2 | 80 | 80 | 38 | 86 | 241 | 72 | 50 | 32 |
| R412007729 | M42x2 | 64 | 98 | 42 | 96 | 271 | 82 | 60 | 36 |

| Materialnummer | SW3 | SW4 | U | α [°] | 1) |
|----------------|-----|-----|-----|-------|----------|
| 1826409008 | 7 | 11 | 0,5 | 8 | 0.05-0.2 |
| R412007860 | 8 | 13 | 0,5 | 8 | 0.05-0.2 |
| R412026140 | 10 | 13 | 0,7 | 6 | 0.05-0.5 |
| R412026141 | 13 | 17 | 0,7 | 8 | 0.05-0.5 |
| R412026142 | 17 | 30 | 1 | 8 | 0.05-0.5 |
| R412026143 | 19 | 30 | 1 | 7 | 0.05-0.5 |
| R412026144 | 24 | 41 | 1 | 6 | 0.05-0.5 |
| R412026145 | 30 | 41 | 1 | 6 | 0.05-0.5 |
| 1826409006 | 41 | 55 | 1 | 8 | 0.05-0.2 |

Ausgleichskupplung PM5, Serie CM2

R412026142

Ausgleichskupplungen

2024-04-04

| Material- nummer | SW3 | SW4 | U | α [°] | 1) |
|---------------------|-----|-----|---|--------------|----------|
| 1826409007 | 55 | 75 | 1 | 8 | 0.05-0.2 |
| R412007729 | 65 | 85 | 1 | 8 | 0.05-0.2 |

1) Axiales Spiel