

Mini slide, Series MSC-HG-HM

R412019005

AVENTICS
Series
MSC Guide
cylinders

2024-04-06

AVENTICS Series MSC Guide cylinders

The AVENTICS Series MSC mini slides have a compact design, require minimal installation space and can be optimally configured for virtually any automated handling task. A wide range of configuration options make the mini slide a truly universal handling component. Precise and reliable operation, coupled with a custom configuration and tailored to the specific application – these attributes allow the mini slides to assume the actuator role in efficient handling. The Series MSC offers high torque absorption and maximum stability. In addition, it provides technical features that guarantee optimally adjusted functions and maintenance-friendly processes. Fast, secure and efficiently connected with the special Easy-2-Combine Interface, the mini slides can be combined with the other components of a handling system without additional mounting plates.



Technical data

Industry	Industrial
Piston Ø	20 mm
Stroke	125 mm
Functional principle	Double-acting
Easy2Combine	capable
double piston	with double piston
Port	G 1/8
Cushioning	hydraulic
Repetitive precision	0,02 mm
Min. working pressure	1 bar
Max. working pressure	10 bar
Min. ambient temperature	0 °C
Max. ambient temperature	60 °C
Medium	Compressed air
Retracting piston force, theoretical	297 N
Extracting piston force, theoretical	396 N
Max. speed	0.8 m/s
Cushioning length	10 mm
Cushioning energy	3.1 J

Mini slide, Series MSC-HG-HM

R412019005

AVENTICS
Series
MSC Guide
cylinders

2024-04-06

Min. oil content of compressed air	0 mg/m ³
Max. oil content of compressed air	1 mg/m ³
Max. particle size	5 µm
Pressure for determining piston forces with integrated ball rail guide	6,3 bar With integrated "High Performance" ball rail system
Weight	3.02 kg

Material

Housing material	Aluminum
Surface housing	anodized
Material piston rod	Stainless Steel
Material front plate	Aluminum
Surface front plate	anodized
Seal material	Polyurethane
Material ball rail table	Aluminum
Surface ball rail table	anodized
Material guide rail	Steel, chrome-plated
Surface guide rail	hardened
Material centering rings	Stainless Steel
Part No.	R412019005

Technical information

Repetitive precision after 100 consecutive strokes: 0,02 mm

Base with air connections at the back and sides

Intermediate strokes can be configured.

Scope of delivery: incl. centering rings

R1 = stroke setting range for forward stroke

R2 = stroke setting range for return stroke

The pressure dew point must be at least 15 °C less than ambient and medium temperature and may not exceed 3 °C.

The oil content of compressed air must remain constant during the life cycle.

Use only the approved oils from AVENTICS. Further information can be found in the "Technical information" document (available in <https://www.emerson.com/en-us/support>).

Dimensions

Mini slide, Series MSC-HG-HM

R412019005

MSC-25

AVENTICS
Series
MSC Guide
cylinders

2024-04-06

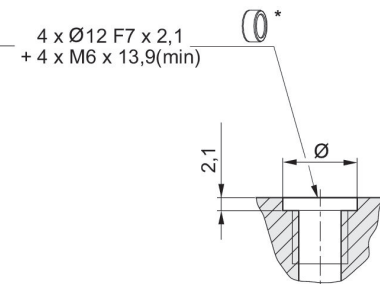
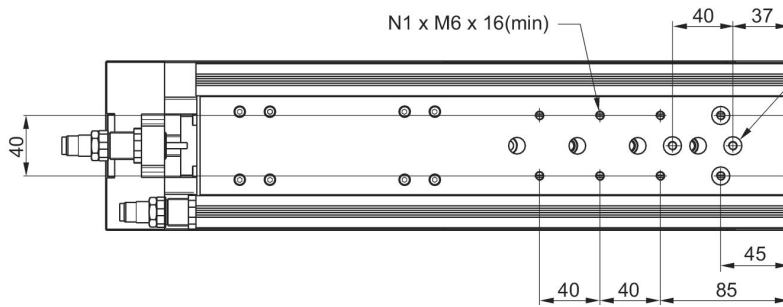
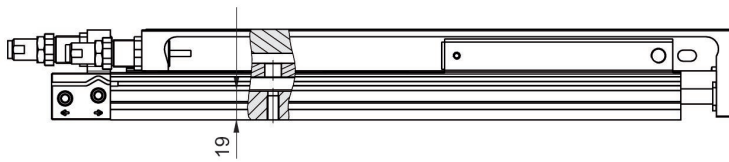
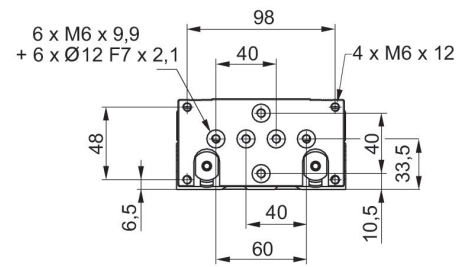
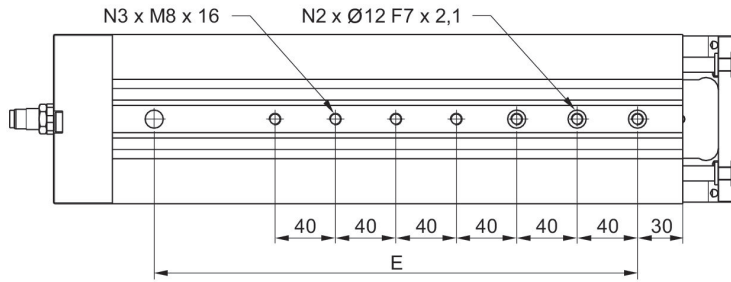

* = centering rings

Part No.	Piston Ø	Stroke	E	N1	N2	N3
R412019030	25	125	200	4	4	5
R480643827	25	125	200	4	4	5
R412019041	25	125	200	4	4	5
R480640211	25	125	200	4	4	5
R412019031	25	150	240	6	4	5
R480643828	25	150	240	6	4	5
R412019042	25	150	240	6	4	5
R480640212	25	150	240	6	4	5
R412019032	25	200	320	6	4	7
R480643829	25	200	320	6	4	7
R412019043	25	200	320	6	4	7
R480640213	25	200	320	6	4	7

Dimensions

Mini slide, Series MSC-HG-HM

R412019005

MSC-20

AVENTICS
Series
MSC Guide
cylinders

2024-04-06

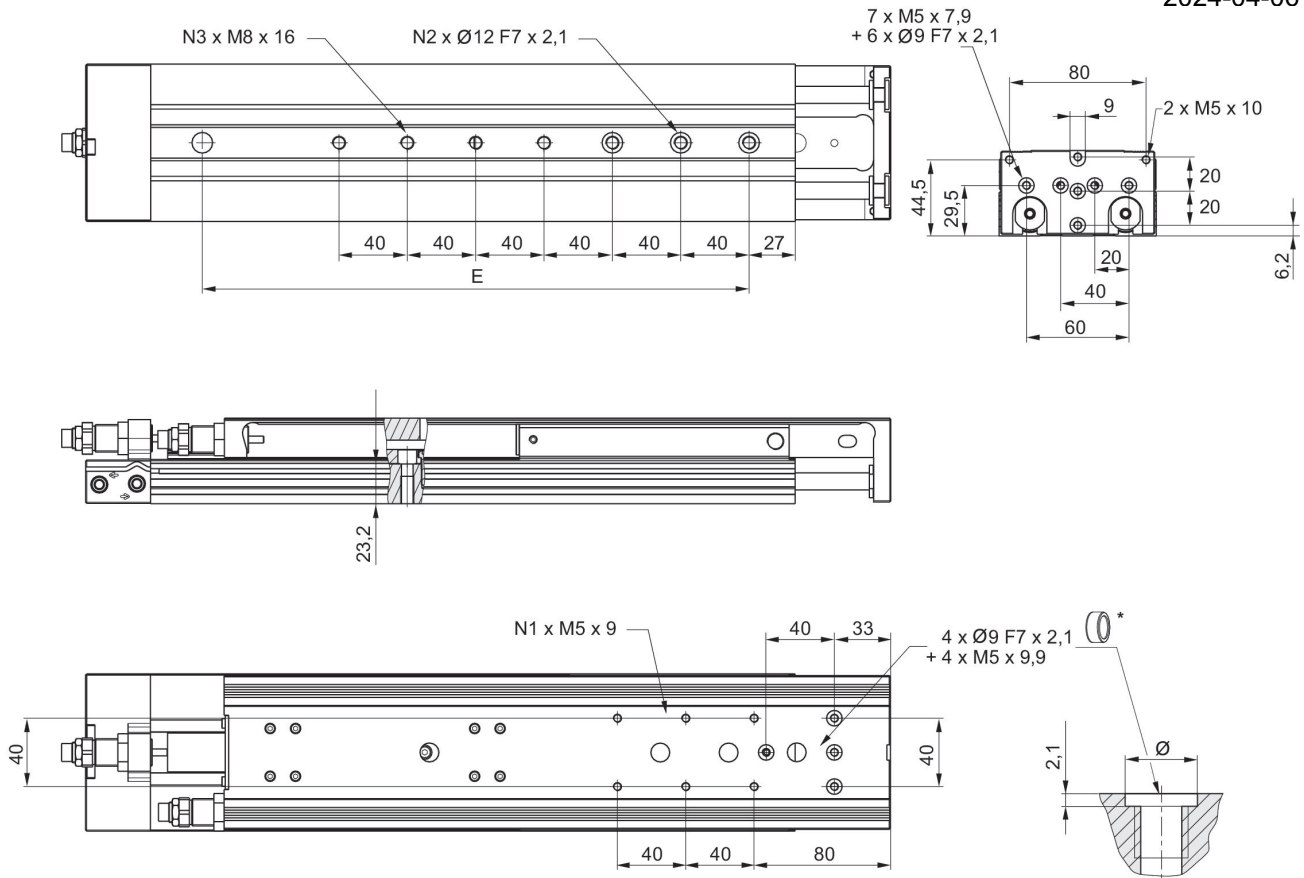

* = centering rings

Part No.	Piston Ø	Stroke	E	N1	N2	N3
R412018917	20	125	200	6	4	5
R480643817	20	125	200	6	4	5
R412019005	20	125	200	6	4	5
R480640205	20	125	200	6	4	5
R412018918	20	150	240	6	4	5
R480643818	20	150	240	6	4	5
R412019006	20	150	240	6	4	5
R480640206	20	150	240	6	4	5
R412018919	20	200	320	6	4	7
R480643819	20	200	320	6	4	7
R412019007	20	200	320	6	4	7
R480640207	20	200	320	6	4	7

Dimensions

Mini slide, Series MSC-HG-HM

R412019005

MSC-16

AVENTICS
Series
MSC Guide
cylinders

2024-04-06

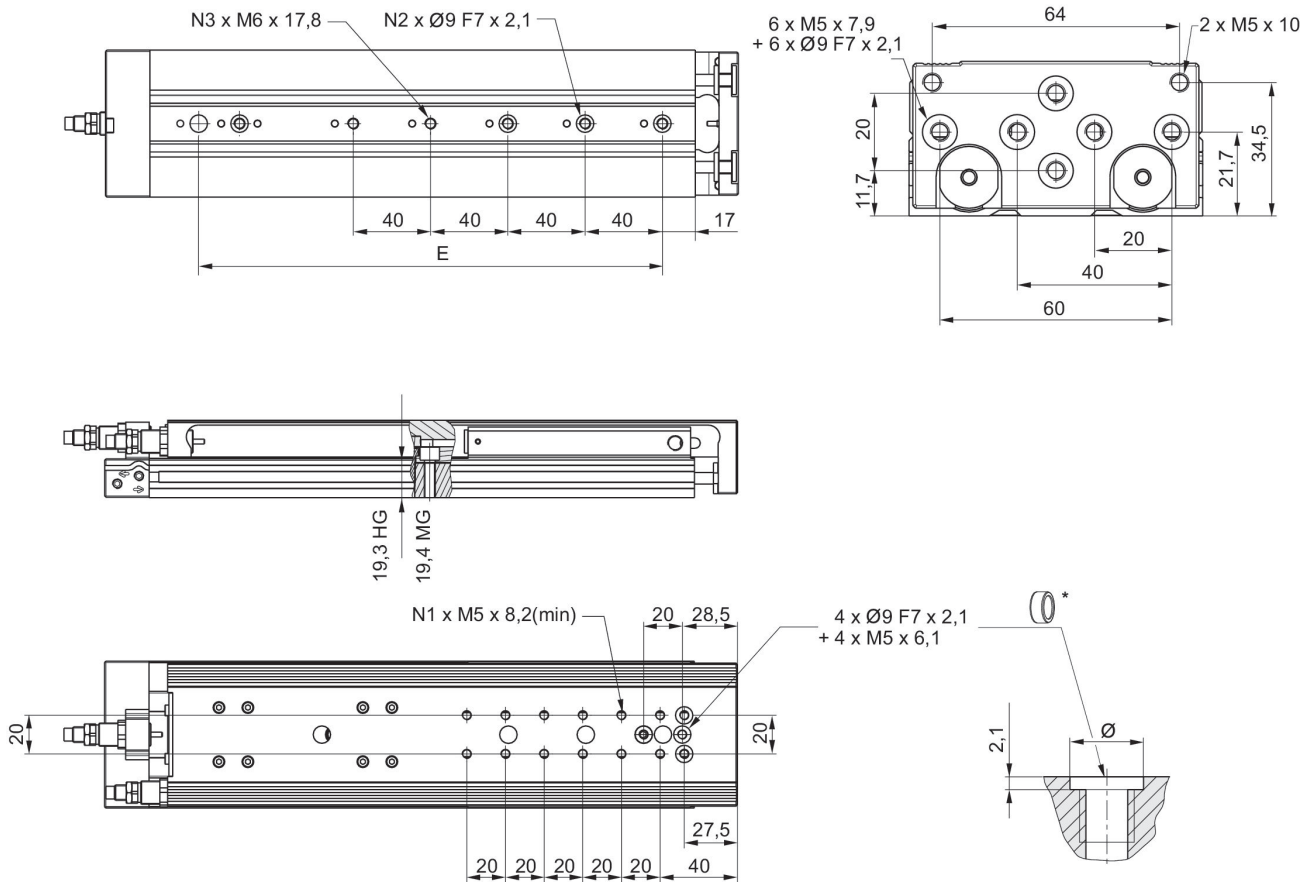

* = centering rings

Part No.	Piston Ø	Stroke	E	N1	N2	N3
R412019175	16	125	200	12	4	5
R480643808	16	125	200	12	4	5
R412019188	16	125	200	12	4	5
R480640200	16	125	200	12	4	5
R412019176	16	150	240	12	4	5
R480643809	16	150	240	12	4	5
R412019189	16	150	240	12	4	5
R480640201	16	150	240	12	4	5

Mini slide, Series MSC-HG-HM

R412019005

AVENTICS
Series
MSC Guide
cylinders

2024-04-06

Dimensions

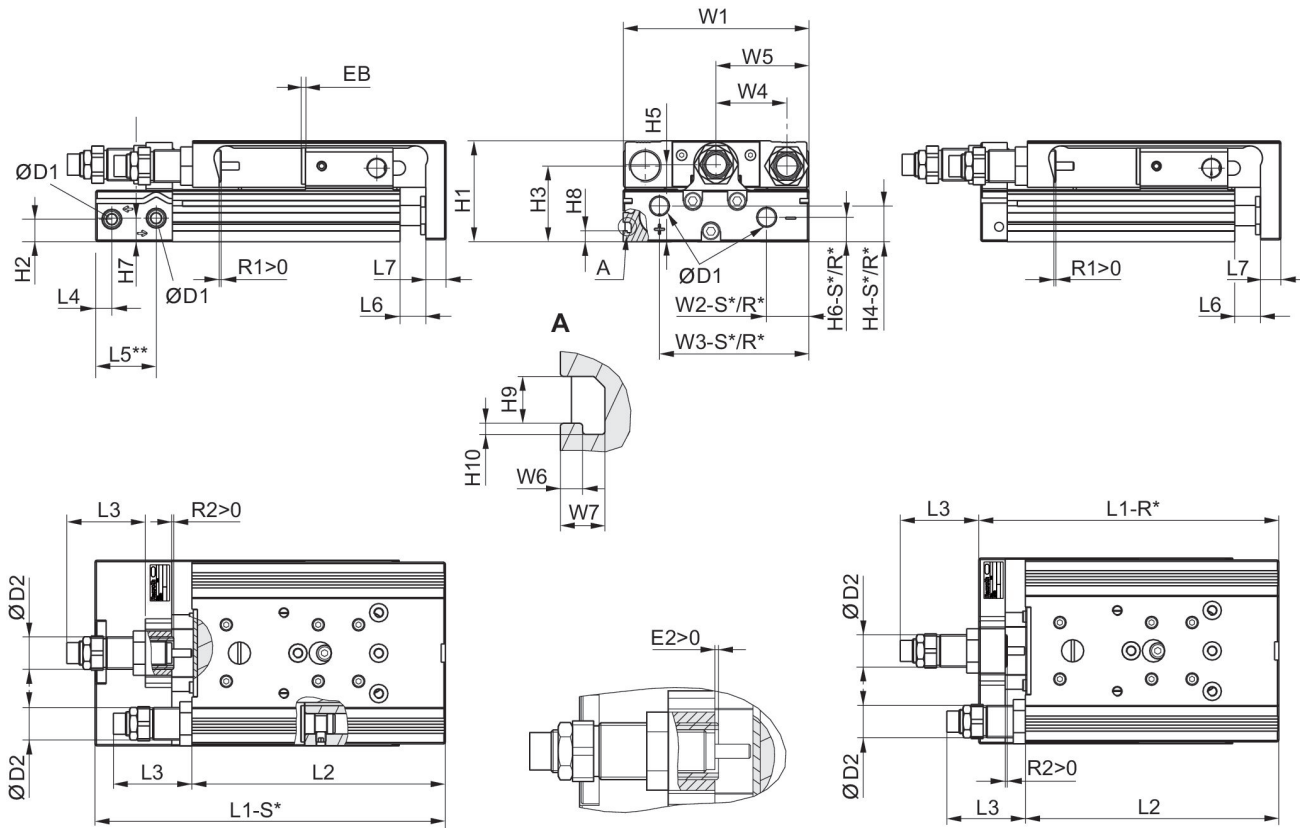

R*: base with air connections only at the back
S*: base with air connections at the back and sides
** Ø 8 has a different reference plane.

Piston Ø	Ø D1	Ø D2	H1	H2	H3	H4-R	H4-S	H5	H6-R
8	M5	M10x1	28	9.6	20.5	-	7.5	19.5	-
12	M5	M12x1	34	5.7	25	11.2	11.2	24.5	5.7
16	M5	M12x1	40	7.2	29	12.2	12.2	31	7.7
20	G 1/8	M16x1,5	50	11.2	37.5	17.3	17.3	38.2	11.7
25	G 1/8	M18x1,5	60	14.2	44	15.5	22.9	46.5	13.2

Piston Ø	H6-S	H7	H8	H9	H10	L3 max.	L4	L5 2)	L6
8	5.5	18	-	-	-	31	9.8	-	1.9
12	5.7	8.3	-	-	-	46.7	7.2	22.5	2
16	7.7	11.2	-	-	-	44.9	6.5	17.7	2
20	12.2	11.7	5.5	4.2	1	48.9	8	30	2.1
25	21.7	16.2	6.9	5.2	1.5	67.7	9	31	2.1

Piston Ø	L7	R2	W1	W2-R	W2-S	W3-R	W3-S	W4	W5
8	6	4.1	50.2	-	19.3	-	30.5	18	W1/2
12	8	12	66	28.8	28.8	53	53	24.5	W1/2
16	10	10.4	76	31	31	60.5	60.5	30	W1/2
20	10	14	92	10	21	74	74	35	W1/2

Mini slide, Series MSC-HG-HM

R412019005

AVENTICS
Series
MSC Guide
cylinders

Piston Ø	L7	R2	W1	W2-R	W2-S	W3-R	W3-S	W4	W5
25	12	16.2	112	11	14	92	92	44	2024-06

Piston Ø	W6	W7
8	-	-
12	-	-
16	-	-
20	2	4
25	2.5	4.8

Stroke-dependent dimensions

Piston Ø	S=10 EB	S=20 EB	S=30 EB	S=40 EB	S=50 EB	S=80 EB	S=100 EB	S=125 EB	S=150 EB
8	12	2	2	2	2	2	-	-	-
12	22	12	2	2	2	2	2	-	-
6	22	12	2	2	2	2	2	2	2
20	22	12	2	2	2	2	2	2	2
25	22	12	2	2	2	2	2	2	2

Piston Ø	S=200 EB	S=10 L1-R	S=20 L1-R	S=30 L1-R	S=40 L1-R	S=50 L1-R	S=80 L1-R	S=100 L1-R	S=125 L1-R
8	-	-	-	-	-	-	-	-	-
12	-	99.3	99.3	99.3	109.3	124.3	170.3	190.3	-
6	-	101.8	101.8	101.8	111.8	126.8	172.8	192.8	281.3
20	2	112.9	112.9	112.9	122.9	137.9	182.9	202.9	287.4
25	2	126.1	126.1	126.1	136.1	149.1	195.1	215.1	292.1

Piston Ø	S=150 L1-R	S=200 L1-R	S=10 L1-S	S=20 L1-S	S=30 L1-S	S=40 L1-S	S=50 L1-S	S=80 L1-S	S=100 L1-S
8	-	-	80.7	80.7	90.7	100.7	120.7	170.7	-
12	-	-	116.2	116.2	116.2	126.2	141.2	187.2	207.2
6	306.3	-	112.7	112.7	112.7	122.7	137.7	183.7	203.7
20	327.4	402.4	137.8	137.8	137.8	147.8	162.8	207.8	227.8
25	332.1	407.1	149.8	149.8	149.8	159.8	172.8	218.8	238.8

Piston Ø	S=125 L1-S	S=150 L1-S	S=200 L1-S	S=10 L2	S=20 L2	S=30 L2	S=40 L2	S=50 L2	S=80 L2
8	-	-	-	73.5	73.5	83.5	93.5	113.5	163.5
12	-	-	-	88.8	88.8	88.8	98.8	113.8	159.8
6	292.2	317.2	-	90.4	90.4	90.4	100.4	115.4	161.4
20	312.3	352.3	427.3	100.5	100.5	100.5	110.5	125.5	170.5
25	315.8	355.8	430.8	111.5	111.5	111.5	121.5	134.5	180.5

Piston Ø	S=100 L2	S=125 L2	S=150 L2	S=200 L2	S=10 R1 max.	S=20 R1 max.	S=30 R1 max.	S=40 R1 max.	S=50 R1 max.
8	-	-	-	-	4.2	4.2	4.2	4.2	4.2
12	179.8	-	-	-	5.7	5.7	5.7	5.7	5.7
6	181.4	269.9	294.9	-	8.7	8.7	8.7	8.7	8.7
20	190.5	275	315	390	12.4	12.4	12.4	12.4	12.4
25	200.5	277.5	317.5	392.5	11.5	11.5	11.5	11.5	10.5

Mini slide, Series MSC-HG-HM

R412019005

AVENTICS
Series
MSC Guide
cylinders

2024-04-06

Piston Ø	S=80 R1 max.	S=100 R1 max.	S=125 R1 max.	S=150 R1 max.	S=200 R1 max.
8	4.2	–	–	–	–
12	5.7	5.7	–	–	–
6	8.7	8.7	8.7	8.7	–
20	12.4	12.4	12.4	12.4	12.4
25	11.5	11.5	11.5	11.5	11.5

Correction factor (a, d) vertical

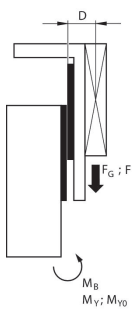

stat.	$M_{B0} = (F_G + F) \cdot D$
dyn.	$M_B = F_G \cdot D$

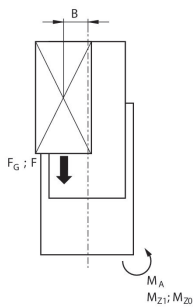

stat.	$M_{A0} = (F_G + F) \cdot B$
dyn.	$M_A = F_G \cdot B$

dyn.	$\frac{M_A}{M_1} + \frac{M_B}{M_2} \leq 1$
stat.	$\frac{M_{A0}}{M_{Z0}} + \frac{M_{B0}}{M_{Y0}} \leq 1$

Correction factor (a, d) horizontal

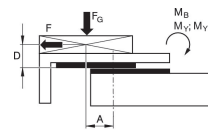

stat.	$M_{B0} = F_G \cdot A + F \cdot D$
dyn.	$M_B = F_G \cdot A$

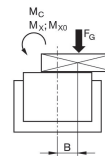

stat.	$M_{C0} = F_G \cdot B$
dyn.	$M_C = F_G \cdot B$

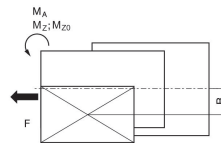

stat.	$M_{A0} = F \cdot B$
dyn.	$M_A = 0$

dyn.	$\frac{M_A}{M_1} + \frac{M_B}{M_2} + \frac{M_C}{M_3} \leq 1$
stat.	$\frac{M_{A0}}{M_{Z0}} + \frac{M_{B0}}{M_{Y0}} + \frac{M_{C0}}{M_{X0}} \leq 1$

$F = m \cdot a$ $F_G = m \cdot g$ $a = 1250 \cdot V^2 / H$
 F = deceleration force [N] F_G = force due to weight [N] m = load mass [kg] a
 = deceleration [m/s²] g = gravitational acceleration 9,81 [m/s²] V = velocity
 [m/s] H = stroke length of shock absorber [mm]

$F = m \cdot a$ $F_G = m \cdot g$ $a = 1250 \cdot V^2 / H$
 F = deceleration force [N] F_G = force due to weight [N] m = load mass [kg] a
 = deceleration [m/s²] g = gravitational acceleration 9,81 [m/s²] V = velocity
 [m/s] H = stroke length of shock absorber [mm]

Mini slide, Series MSC-HG-HM

R412019005

AVENTICS
Series
MSC Guide
cylinders
2024-04-06

Correction factor (a, d)

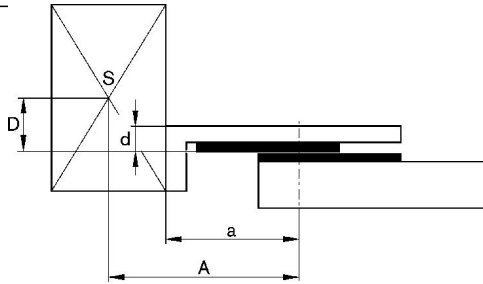

Minimum and maximum moving mass

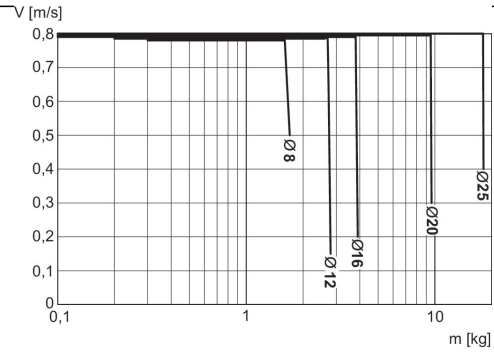

V = velocity [m/s]
m = mass

Correction factor for required speed: retracting and extending, horizontal

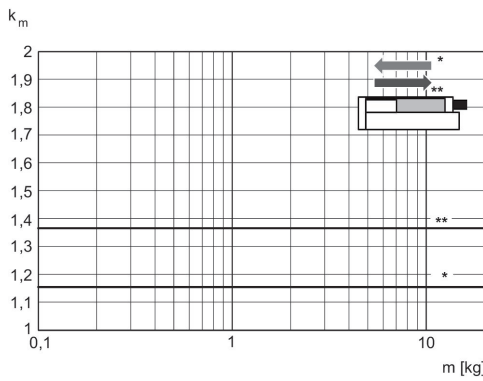

* retracting
** extracting
 $V = s/1000 \cdot t \cdot k_m$
V = velocity [m/s]
S = stroke

Correction factor for required speed: extending, vertical, downwards

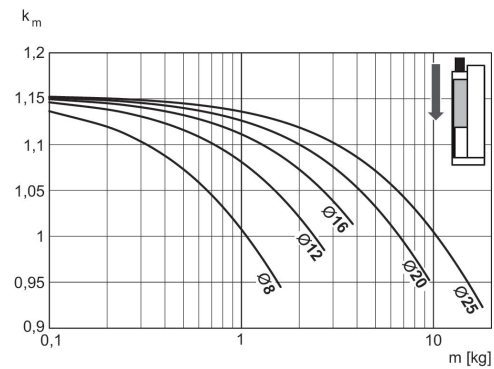

$V = s/1000 \cdot t \cdot k_m$
V = velocity [m/s]
S = stroke [mm]
t = time [s] for one stroke
m = mass

Mini slide, Series MSC-HG-HM

R412019005

AVENTICS

Series

MSC Guide

cylinders

2024-04-06

Correction factor for required speed:
retracting, vertical, downwards

Correction factor for required speed:
retracting, vertical, upwards

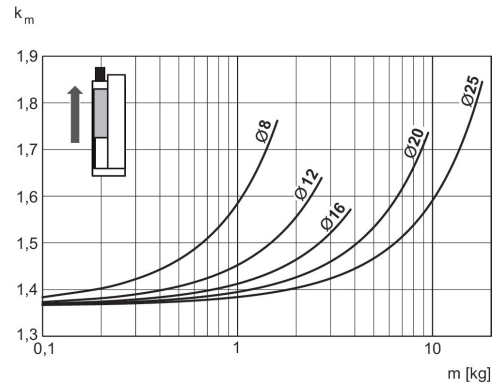
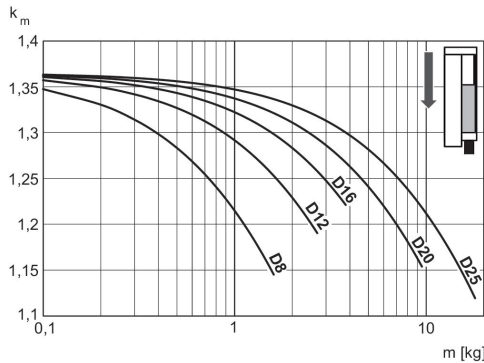

$V = s/1000 \cdot t \cdot k_m$
 $V = \text{velocity [m/s]}$
 $S = \text{stroke [mm]}$
 $t = \text{time [s] for one stroke}$
 $m = \text{mass}$

$V = s/1000 \cdot t \cdot k_m$
 $V = \text{velocity [m/s]}$
 $S = \text{stroke [mm]}$
 $t = \text{time [s] for one stroke}$
 $m = \text{mass}$

Correction factor for required speed:
extending, vertical, upwards

Max. extracting speed

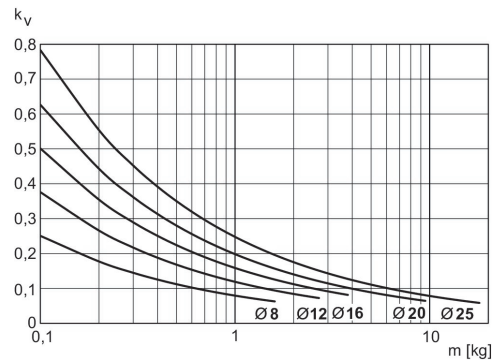
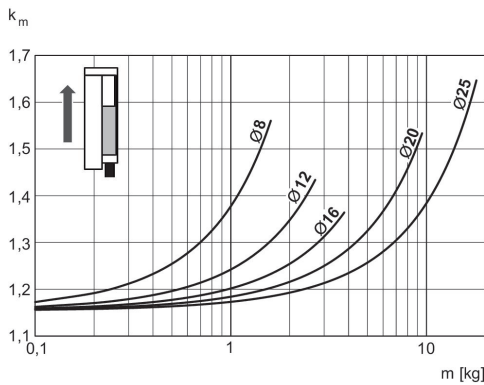

$V = s/1000 \cdot t \cdot k_m$
 $V = \text{velocity [m/s]}$
 $S = \text{stroke [mm]}$
 $t = \text{time [s] for one stroke}$
 $m = \text{mass}$

$V = \sqrt{s \cdot k_v}$
 $V = \text{velocity [m/s]}$
 $S = \text{stroke [mm]}$
 $m = \text{mass}$

Mini slide, Series MSC-HG-HM

R412019005

AVENTICS
Series
MSC Guide
cylinders

2024-04-06

Max. additional moving mass, vertical

Max. additional moving mass,
horizontal

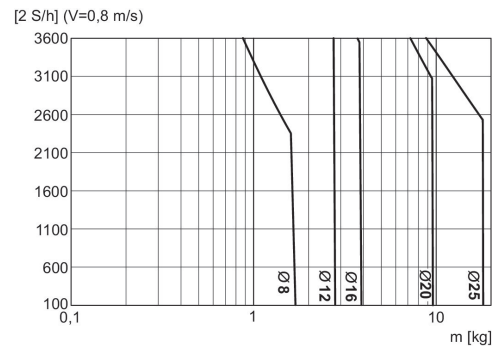
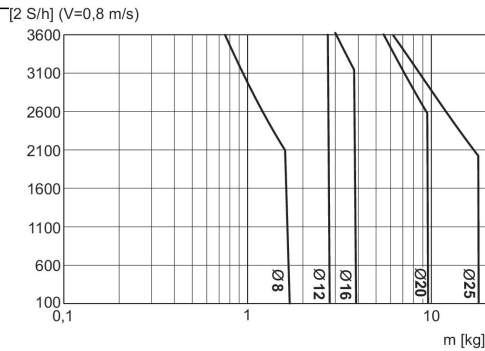

S = stroke [mm]
2 x S = 1 cycle
V = velocity [m/s]
m = mass

S = stroke [mm]
2 x S = 1 cycle
V = velocity [m/s]
m = mass

Load capacity

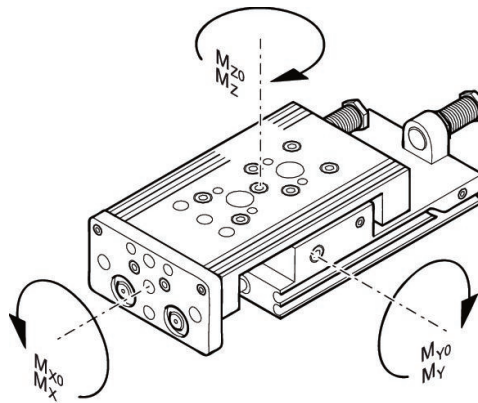

M = max. permissible torque

Correction factor (a)

Part No.	Piston Ø	S	a [mm]	d [mm]	Mx0 Static moment M [Nm]	My0 Static moment M [Nm]	Mz0 Static moment M [Nm]	Mx Dynamic moment M [Nm]	My Dynamic moment M [Nm]
R412019211	8	20	50	14	7	7	7	1.1	1.9
R412019212	8	30	60	14	7	7	7	1.1	1.9
R412019213	8	40	70	14	7	7	7	1.1	1.9
R412019214	8	50	80	14	9	13	13	1.3	2.9
R412019215	8	80	125	14	13	25	25	1.3	3.8
R412019199	12	30	64.5	16	20	14	14	4.2	4.4
R412019200	12	40	74.5	16	20	14	14	4.2	4.4
R412019201	12	50	84.5	16	23	19	19	4.6	5.6
R412019202	12	80	125	16	33	32	32	5.2	8.2
R412019203	12	100	145	16	33	32	32	5.2	8.2
R412019183	16	30	65.5	15	35	25	25	6.5	6.6
R412019184	16	40	75.5	15	35	25	25	6.5	6.6

Mini slide, Series MSC-HG-HM

R412019005

AVENTICS
Series
MSC Guide
cylinders

Part No.	Piston Ø	S	a [mm]	d [mm]	Mx0 Static moment M [Nm]	My0 Static moment M [Nm]	Mz0 Static moment M [Nm]	Mx Dynamic moment M [Nm]	My Dynamic moment M [Nm]
R412019185	16	50	85.5	15	38	29	29	7	7.6
R412019186	16	80	126	15	74	58	58	8.7	12.8
R412019187	16	100	146	15	74	58	58	8.7	12.8
R412019188	16	125	198.5	15	88	118	118	15.2	31.2
R412019189	16	150	223.5	15	88	119	119	15.2	31.2
R412019000	20	30	70.5	20	87	57	57	9.6	12
R412019001	20	40	80.5	20	87	57	57	9.6	12
R412019002	20	50	90.5	20	93	65	65	10	13.3
R412019003	20	80	130.5	20	116	99	99	11.7	19
R412019004	20	100	150.5	20	116	99	99	11.7	19
R412019006	20	150	233.5	20	126	152	152	19	45.4
R412019007	20	200	296	20	126	179	179	19	53.4
R412019036	25	30	77.5	24	100	90	90	22.9	19.5
R412019037	25	40	87.5	24	100	90	90	22.9	19.5
R412019038	25	50	96.5	24	100	90	90	15.3	13
R412019039	25	80	137	24	110	129	129	18.8	20.8
R412019040	25	100	157	24	110	129	129	18.8	20.8
R412019041	25	125	201	24	145	180	180	20.4	44.1
R412019042	25	150	236.5	24	145	201	201	20.4	49.2
R412019043	25	200	299	24	145	236	236	20.4	57.8

Part No.	Mz Dynamic moment M [Nm]
R412019211	1.9
R412019212	1.9
R412019213	1.9
R412019214	2.9
R412019215	3.8
R412019199	4.4
R412019200	4.4
R412019201	5.6
R412019202	8.2
R412019203	8.2
R412019183	6.6
R412019184	6.6
R412019185	7.6
R412019186	12.8
R412019187	12.8
R412019188	31.2
R412019189	31.2
R412019000	12
R412019001	12
R412019002	13.3
R412019003	19
R412019004	19

Mini slide, Series MSC-HG-HM

R412019005

AVENTICS
Series
MSC Guide
cylinders

2024-04-06

Part No.	Mz Dynamic moment M [Nm]
R412019006	45.4
R412019007	53.4
R412019036	19.5
R412019037	19.5
R412019038	13
R412019039	20.8
R412019040	20.8
R412019041	44.1
R412019042	49.2
R412019043	57.8

Overview drawing

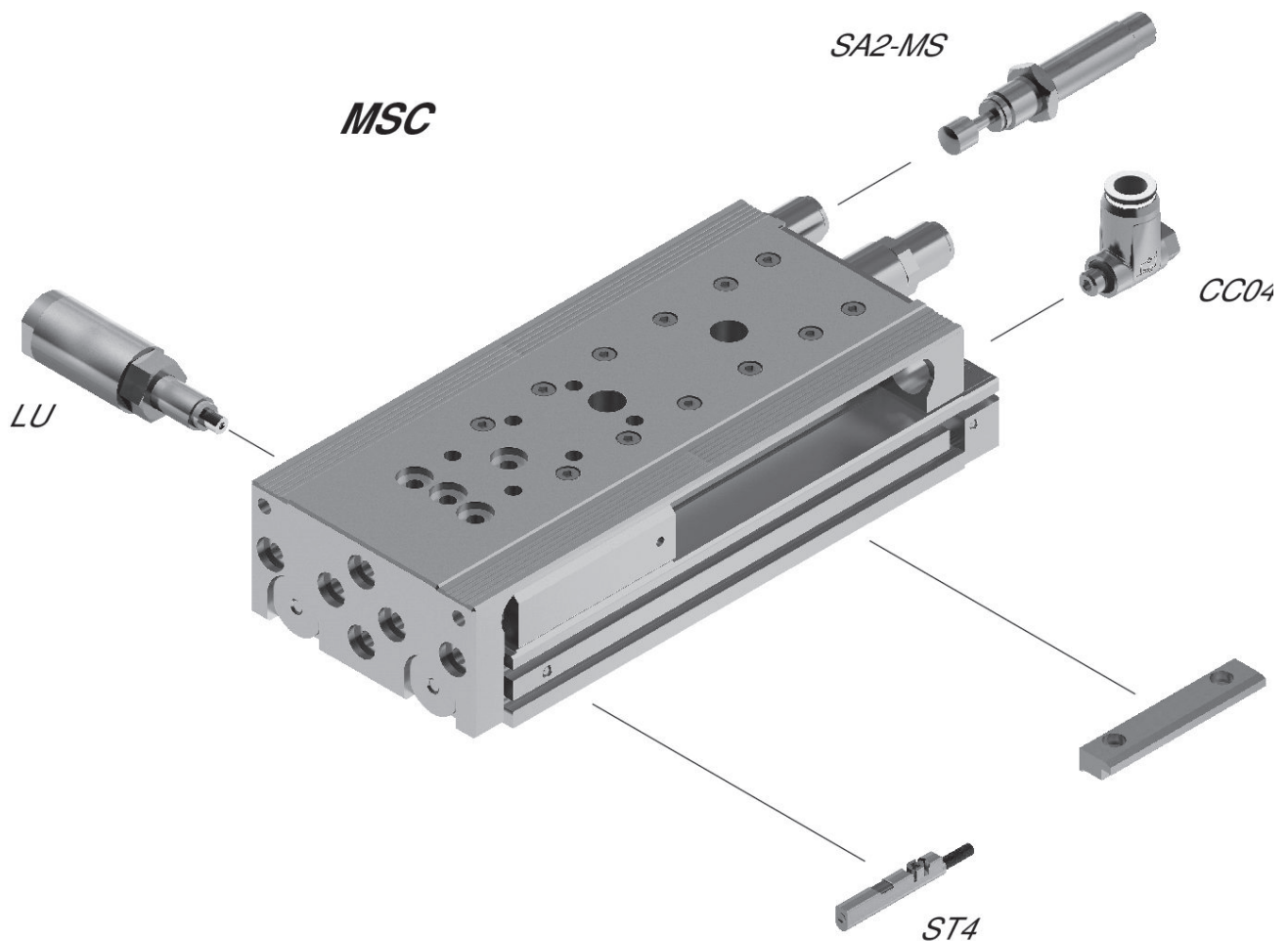

NOTE: This overview drawing is only for orientation to indicate where the various accessory parts can be fastened to the cylinder. The illustration has been simplified for this purpose. It is thus not possible to derive the dimensions from this overview.

Mini slide, Series MSC-HG-HM

R412019005

AVENTICS
Series
MSC Guide
cylinders

2024-04-06

Weight of moving parts [kg]

Piston Ø	S=10	S=20	S=30	S=40	S=50	S=80	S=100	S=125	S=150
8	0.14	0.14	0.155	0.165	0.195	0.265	–	–	–
12	0.255	0.255	0.26	0.28	0.315	0.403	0.46	–	–
16	0.375	0.375	0.375	0.4	0.45	0.615	0.65	0.725	0.765
20	0.655	0.655	0.655	0.69	0.765	0.985	1.035	1.2	1.29
25	1	1	1	1.1	1.225	1.45	1.625	1.885	2.085

Piston Ø	S=200
8	–
12	–
16	–
20	1.54
25	2.445