

Mini cuna, Serie MSC-HG-EE

R412018919

Cilindros
de guído
AVENTICS
serie MSC

2024-04-06

Cilindros de guído AVENTICS serie MSC

Las mini guías de AVENTICS serie MSC tienen un diseño compacto, apenas necesitan espacio de instalación y se pueden configurar de forma óptima para prácticamente cualquier tarea de manipulación automatizada. {1}La versatilidad de sus posibilidades de configuración convierten a la mini guía en un componente de manipulación auténticamente universal. {1} El funcionamiento preciso y fiable acompañado de una configuración y personalización para cada aplicación: estas propiedades hacen que las mini placas deslizantes asuman el papel de actuador en una manipulación eficiente. La serie MSC aporta absorción de par elevada y máxima estabilidad. Además, presenta unas características técnicas que garantizan funciones óptimamente adaptadas y procesos de fácil mantenimiento. Rápido, seguro y conectado de forma eficiente con la Interfaz especial Easy-2-Combine, las mini placas deslizantes se pueden combinar con los otros componentes de un sistema de manipulación sin placas de montaje adicionales.

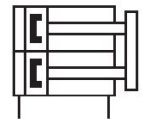
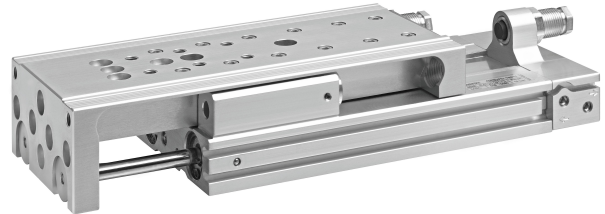

Datos técnicos

Sector	Industria
Ø del émbolo	20 mm
Carrera	200 mm
Principio activo	de efecto doble
Easy2Combine	compatible
émbolo doble	con émbolo doble
Orificio	G 1/8
Amortiguación	elástico
Presión de funcionamiento mín.	1 bar
Presión de funcionamiento máx.	10 bar
Temperatura ambiente mín.	0 °C
Temperatura ambiente máx.	60 °C
Fluido	Aire comprimido
Fuerza de émbolo durante retracción, teórica	297 N
Fuerza de émbolo durante extracción, teórica	396 N
Velocidad máx.	0.8 m/s
Longitud de amortiguación	1.2 mm
Energía de amortiguación	0.4 J
Contenido de aceite del aire comprimido min.	0 mg/m ³

Mini cuna, Serie MSC-HG-EE

R412018919

Cilindros
de guiado
AVENTICS
serie MSC

2024-04-06

Contenido de aceite del aire comprimido máx.	1 mg/m ³
Tamaño de partículas máx.	5 µm
Presión para determinar las fuerzas de émbolo con guía de bolas integrada	6,3 bar Con patín de bolas sobre raíles integrado de alto rendimiento
Peso	4.12 kg

Material

Material carcasa	Aluminio
Superficie Carcasa	anodizado
Material vástago	Acero inoxidable
Material placa frontal	Aluminio
Superficie Placa frontal	anodizado
Material juntas	Poliuretano
Material mesa de guía	Aluminio
Superficie Mesa de guía	anodizado
Material riel de guía	Acero, cromado
Superficie Riel de guía	templado
Material anillos de centraje	Acero inoxidable
Nº de material	R412018919

Información técnica

Precisión de repetición después de 100 carreras consecutivas: 0,3 mm

Versión de la base con conexiones de aire detrás y en el lateral

Las carreras intermedias pueden configurarse.

Volumen de entrega: incl. anillos de centraje

R1 = gama de ajuste de carrera para el avance

R2 = gama de ajuste de carrera para el retorno

Ø 8 tiene otra superficie de referencia.

El punto de condensación de presión se debe situar como mínimo 15 °C por debajo de la temperatura ambiental y del medio, y debe ser como máx. de 3 °C .

El contenido de aceite del aire comprimido debe permanecer constante durante toda la vida útil.

Utilice solo aceites permitidos por AVENTICS. Encontrará más información en el documento "Información técnica" (disponible en el <https://www.emerson.com/en-us/support>).

Mini cuna, Serie MSC-HG-EE

R412018919

Cilindros
de guía
AVENTICS
serie MSC

2024-04-06

Dimensiones

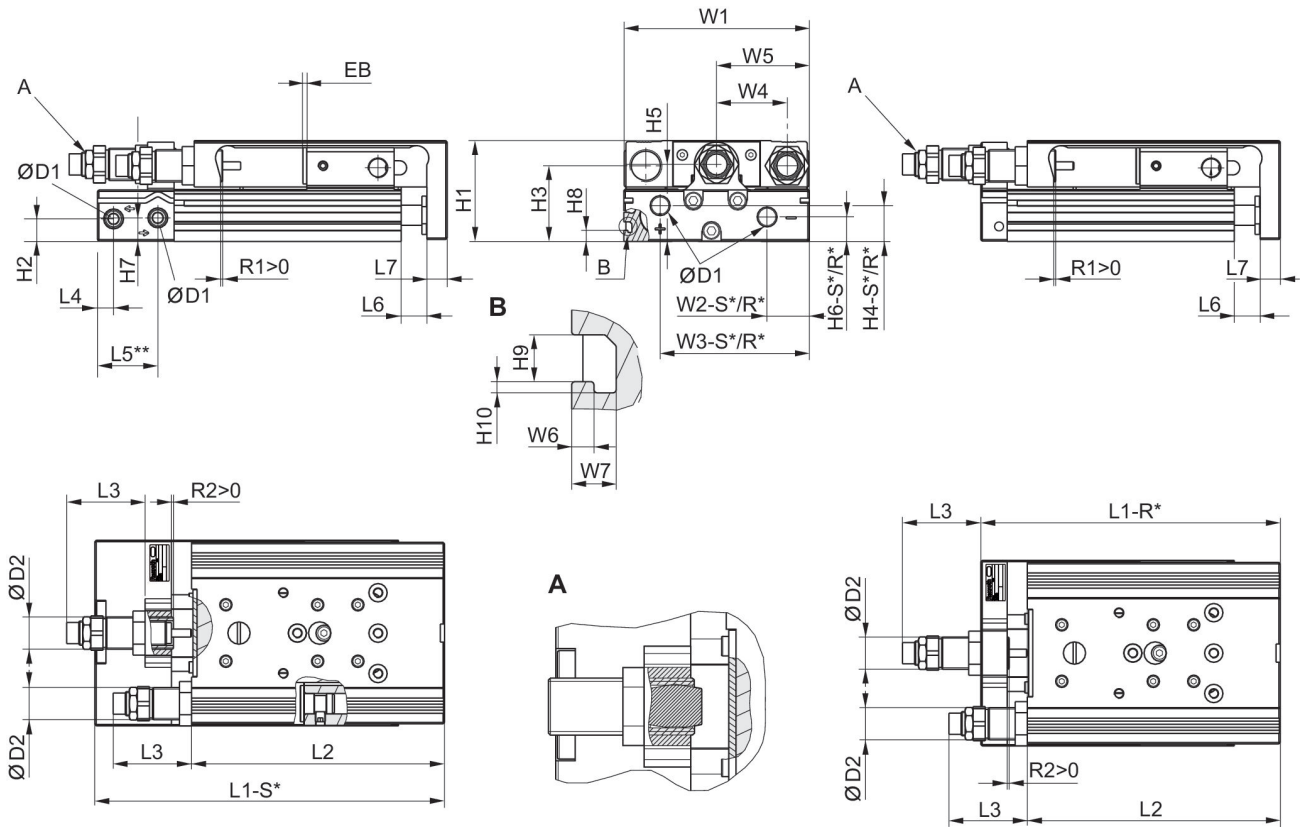

R*: versión de la base con conexiones de aire solo detrás
S*: versión de la base con conexiones de aire detrás y en el lateral
** Ø 8 tiene otra superficie de referencia.

Dimensiones

Ø del émbolo	Ø D1	Ø D2	H1	H2	H3	H4-R	H4-S	H5	H6-R
8	M5	M10x1	28	9.6	20.5	-	7.5	19.5	-
12	M5	M12x1	34	5.7	25	11.2	11.2	24.5	5.7
16	M5	M12x1	40	7.2	29	12.2	12.2	31	7.7
20	G 1/8	M16x1,5	50	11.2	37.5	17.3	17.3	38.2	11.7
25	G 1/8	M18x1,5	60	14.2	44	15.5	22.9	46.5	13.2

Ø del émbolo	H6-S	H7	H8	H9	H10	L3 máx.	L4	L5 2)	L6
8	5.5	18	-	-	-	16	9.8	-	1.9
12	5.7	8.3	-	-	-	20.2	7.2	22.5	2
16	7.7	11.2	-	-	-	18.4	6.5	17.7	2
20	12.2	11.7	5.5	4.2	1	27.9	8	30	2.1
25	21.7	16.2	6.9	5.2	1.5	29.2	9	31	2.1

Ø del émbolo	L7	R2 máx.	W1	W2-R	W2-S	W3-R	W3-S	W4	W5
8	6	9.1	50.2	-	19.3	-	30.5	18	W1/2
12	8	14	66	28.8	28.8	53	53	24.5	W1/2

Mini cuna, Serie MSC-HG-EE

R412018919

Cilindros
de guíado
AVENTICS
serie MSC

Ø del émbolo	L7	R2 máx.	W1	W2-R	W2-S	W3-R	W3-S	W4	W5
16	10	12.4	76	31	31	60.5	60.5	30	W1/2
20	10	19.9	92	10	21	74	74	35	W1/2
25	12	22.2	112	11	14	92	92	44	W1/2

Ø del émbolo	W6	W7
8	-	-
12	-	-
16	-	-
20	2	4
25	2.5	4.8

Medidas en función de la carrera

Ø del émbolo	S=10 EB	S=20 EB	S=30 EB	S=40 EB	S=50 EB	S=80 EB	S=100 EB	S=125 EB	S=150 EB
8	12	2	2	2	2	2	-	-	-
12	22	12	2	2	2	2	2	-	-
16	22	12	2	2	2	2	2	2	2
20	22	12	2	2	2	2	2	2	2
25	22	12	2	2	2	2	2	2	2

Ø del émbolo	S=200 EB	S=10 L1-R	S=20 L1-R	S=30 L1-R	S=40 L1-R	S=50 L1-R	S=80 L1-R	S=100 L1-R	S=125 L1-R
8	-	-	-	-	-	-	-	-	-
12	-	101	101	101	111	126	172	192	-
16	-	103.5	103.5	103.5	113.5	128.5	174.5	194.5	283
20	2	115	115	115	125	140	185	205	289.5
25	2	128.5	128.5	128.5	138.5	151.5	197.5	217.5	294.5

Ø del émbolo	S=150 L1-R	S=200 L1-R	S=10 L1-S	S=20 L1-S	S=30 L1-S	S=40 L1-S	S=50 L1-S	S=80 L1-S	S=100 L1-S
8	-	-	81.7	81.7	91.7	101.7	121.7	171.7	-
12	-	-	117.9	117.9	117.9	127.9	142.9	188.9	208.9
16	308	-	114.4	114.4	114.4	124.4	139.4	185.4	205.4
20	329.5	404.5	139.9	139.9	139.9	149.9	164.9	209.9	229.9
25	334.5	409.5	152.2	152.2	152.2	162.2	175.2	221.2	241.2

Ø del émbolo	S=125 L1-S	S=150 L1-S	S=200 L1-S	S=10 L2	S=20 L2	S=30 L2	S=40 L2	S=50 L2	S=80 L2
8	-	-	-	73.5	73.5	83.5	93.5	113.5	163.5
12	-	-	-	88.8	88.8	88.8	98.8	113.8	159.8
16	293.9	318.9	-	90.4	90.4	90.4	100.4	115.4	161.4
20	314.4	354.4	429.4	100.5	100.5	100.5	110.5	125.5	170.5
25	318.2	358.2	433.2	111.5	111.5	111.5	121.5	134.5	180.5

Ø del émbolo	S=100 L2	S=125 L2	S=150 L2	S=200 L2	S=10 R1 máx.	S=20 R1 máx.	S=30 R1 máx.	S=40 R1 máx.	S=50 R1 máx.
8	-	-	-	-	9.2	9.2	9.2	9.2	9.2
12	179.8	-	-	-	7.7	7.7	7.7	7.7	7.7
16	181.4	269.9	294.9	-	10.7	10.7	10.7	10.7	10.7
20	190.5	275	315	390	18.4	18.4	18.4	18.4	18.4

Mini cuna, Serie MSC-HG-EE

R412018919

Cilindros
de guía
AVENTICS
serie MSC

Ø del émbolo	S=100 L2	S=125 L2	S=150 L2	S=200 L2	S=10 R1 máx.	S=20 R1 máx.	S=30 R1 máx.	S=40 R1 máx.	S=50 R1 máx.
25	200.5	277.5	317.5	392.5	17.5	17.5	17.5	17.5	17.5

2024-04-06

Ø del émbolo	S=80 R1 máx.	S=100 R1 máx.	S=125 R1 máx.	S=150 R1 máx.	S=200 R1 máx.
8	9.2	-	-	-	-
12	7.7	7.7	-	-	-
16	10.7	10.7	10.7	10.7	-
20	18.4	18.4	18.4	18.4	18.4
25	17.5	17.5	17.5	17.5	17.5

Dimensiones MSC-25

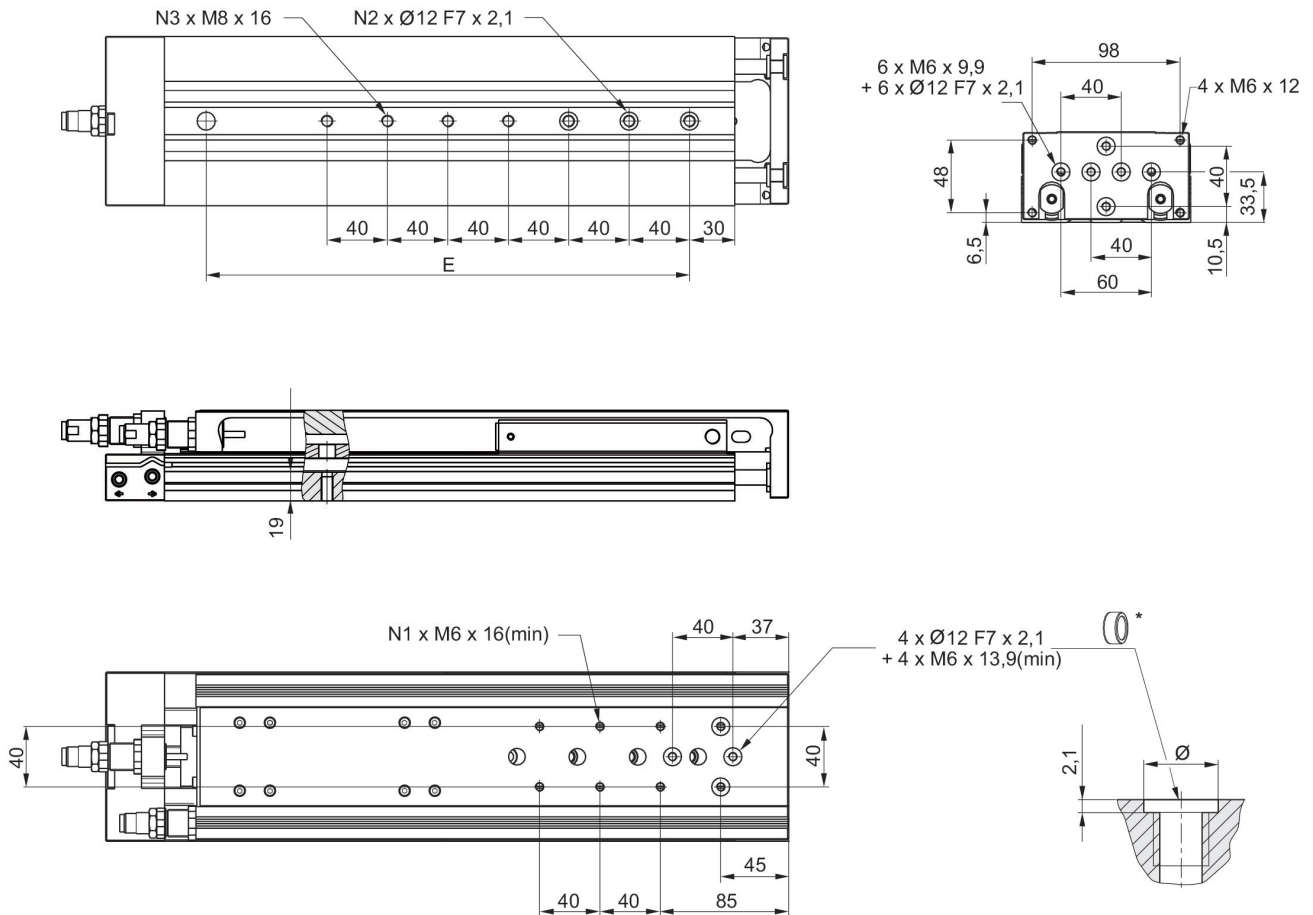

\ast = anillos de centrado

N° de material	Ø del émbolo	Carrera	E	N1	N2	N3
R412019030	25	125	200	4	4	5
R480643827	25	125	200	4	4	5
R412019041	25	125	200	4	4	5

Mini cuna, Serie MSC-HG-EE

R412018919

Cilindros
de guiado
AVENTICS
serie MSC

2024-04-06

N° de material	Ø del émbolo	Carrera	E	N1	N2	N3
R480640211	25	125	200	4	4	5
R412019031	25	150	240	6	4	5
R480643828	25	150	240	6	4	5
R412019042	25	150	240	6	4	5
R480640212	25	150	240	6	4	5
R412019032	25	200	320	6	4	7
R480643829	25	200	320	6	4	7
R412019043	25	200	320	6	4	7
R480640213	25	200	320	6	4	7

Dimensiones MSC-20

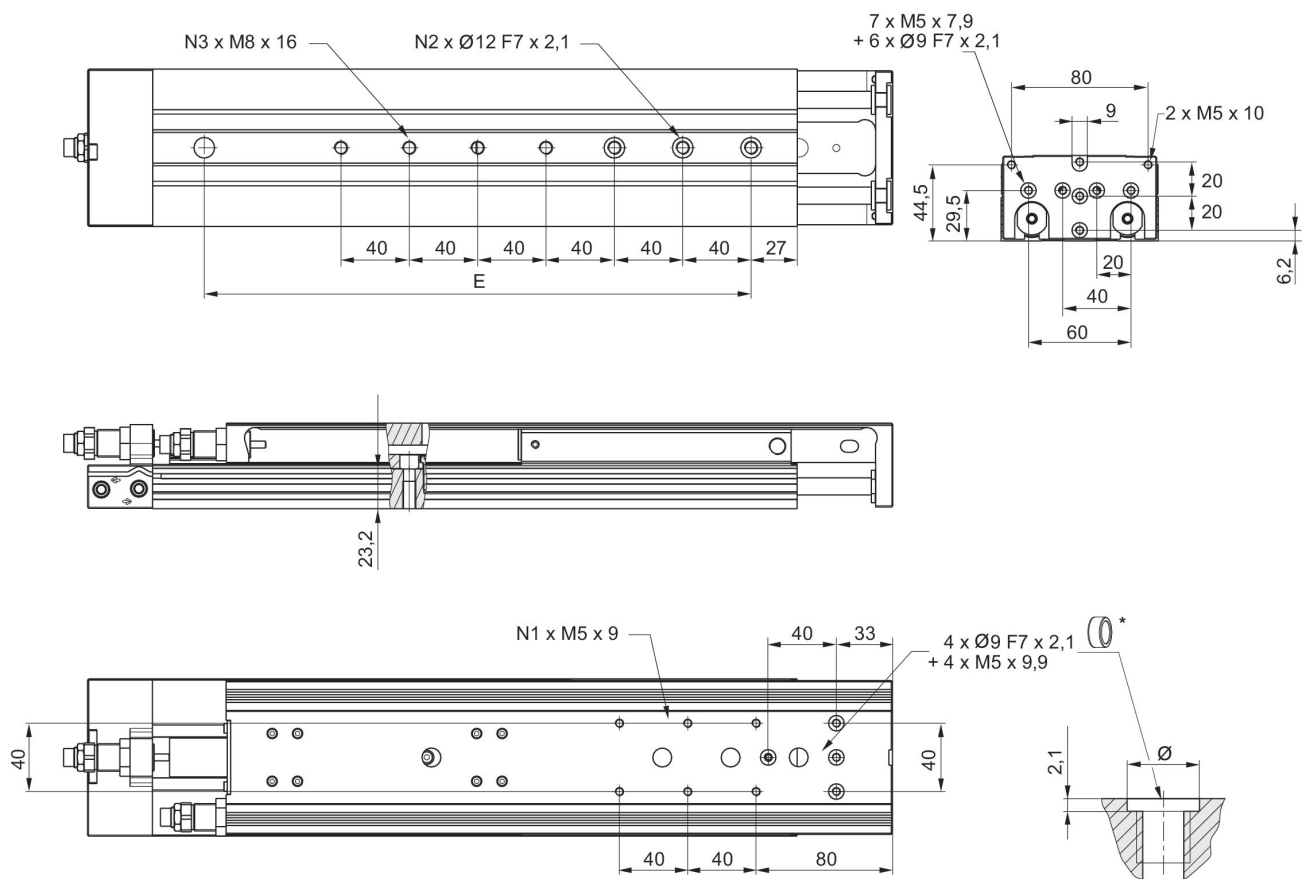

* = anillos de centrado

N° de material	Ø del émbolo	Carrera	E	N1	N2	N3
R412018917	20	125	200	6	4	5
R480643817	20	125	200	6	4	5
R412019005	20	125	200	6	4	5
R480640205	20	125	200	6	4	5

Mini cuna, Serie MSC-HG-EE

R412018919

Cilindros
de guado
AVENTICS
serie MSC

2024-04-06

N de material	∅ del bolo	Carrera	E	N1	N2	N3
R412018918	20	150	240	6	4	5
R480643818	20	150	240	6	4	5
R412019006	20	150	240	6	4	5
R480640206	20	150	240	6	4	5
R412018919	20	200	320	6	4	7
R480643819	20	200	320	6	4	7
R412019007	20	200	320	6	4	7
R480640207	20	200	320	6	4	7

Dimensiones MSC-16

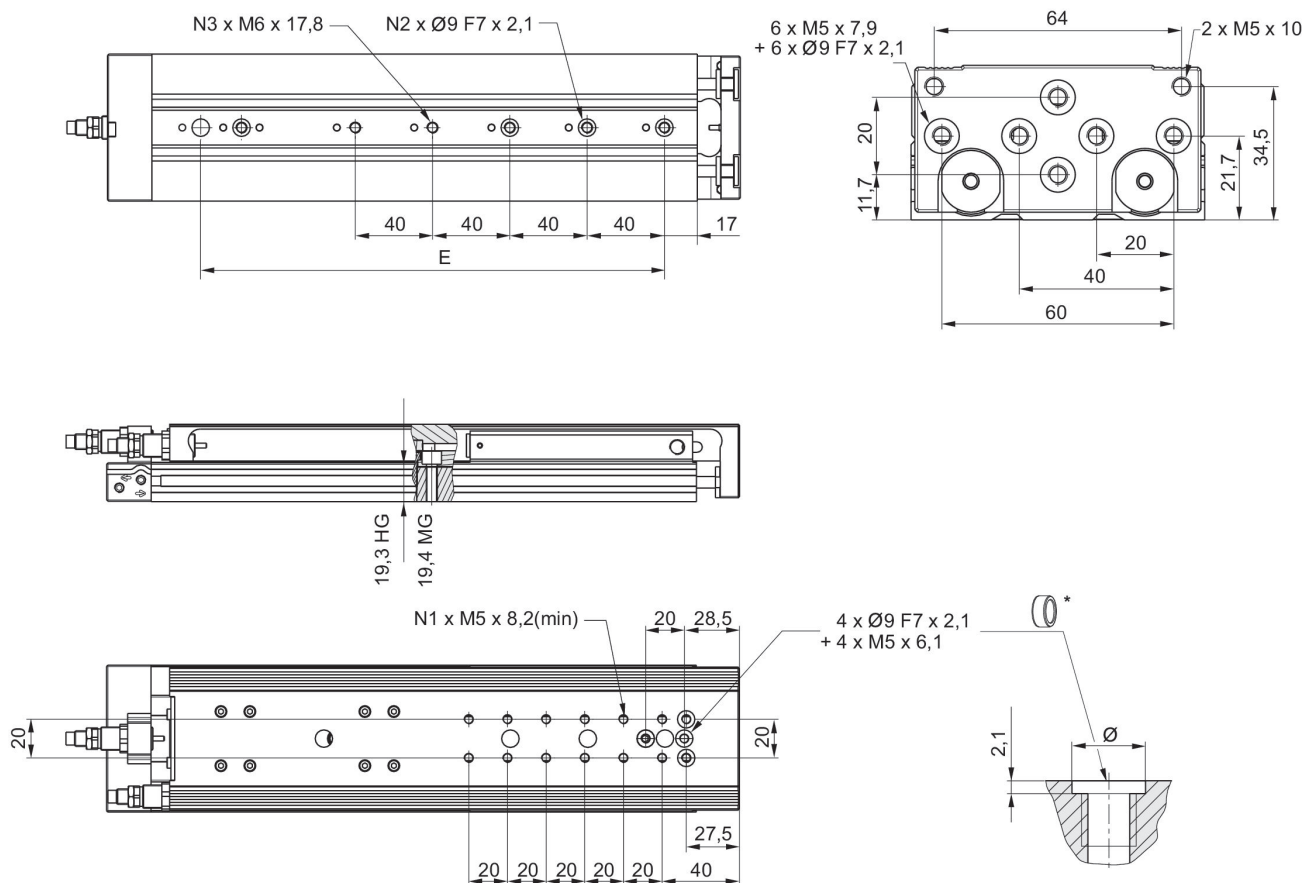

* = anillos de centrado

N de material	∅ del bolo	Carrera	E	N1	N2	N3
R412019175	16	125	200	12	4	5
R480643808	16	125	200	12	4	5
R412019188	16	125	200	12	4	5
R480640200	16	125	200	12	4	5

Mini cuna, Serie MSC-HG-EE

R412018919

Cilindros de guía
AVENTICS
serie MSC

2024-04-06

N° de material	Ø del émbolo	Carrera	E	N1	N2	N3
R412019176	16	150	240	12	4	5
R480643809	16	150	240	12	4	5
R412019189	16	150	240	12	4	5
R480640201	16	150	240	12	4	5

factor de corrección (a, d) vertical

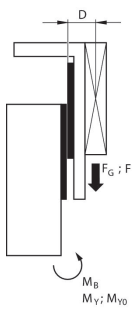

stat.	$M_{B0} = (F_G + F) \cdot D$
dyn.	$M_B = F_G \cdot D$

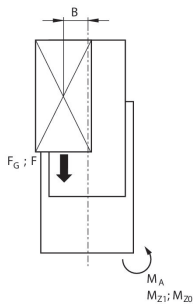

stat.	$M_{A0} = (F_G + F) \cdot B$
dyn.	$M_A = F_G \cdot B$

dyn.	$\frac{M_A}{M_1} + \frac{M_B}{M_2} \leq 1$
stat.	$\frac{M_{A0}}{M_{Z0}} + \frac{M_{B0}}{M_{Y0}} \leq 1$

factor de corrección (a, d) horizontal

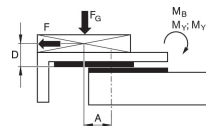

stat.	$M_{B0} = F_G \cdot A + F \cdot D$
dyn.	$M_B = F_G \cdot A$

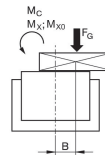

stat.	$M_{C0} = F_G \cdot B$
dyn.	$M_C = F_G \cdot B$

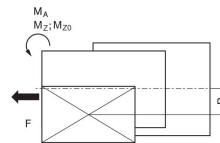

stat.	$M_{A0} = F \cdot B$
dyn.	$M_A = 0$

dyn.	$\frac{M_A}{M_1} + \frac{M_B}{M_2} + \frac{M_C}{M_3} \leq 1$
stat.	$\frac{M_{A0}}{M_{Z0}} + \frac{M_{B0}}{M_{Y0}} + \frac{M_{C0}}{M_{X0}} \leq 1$

$F = m \cdot a$ $F_G = m \cdot g$ $a = 1250 \cdot V^2 / H$

F = fuerza de retardo [N] F_G = fuerza de peso [N] m = masa de carga [kg] a = retardo [m/s²] g = aceleración de la gravedad 9,81 [m/s²] V = velocidad H = longitud de carrera de amortiguador [mm]

$F = m \cdot a$ $F_G = m \cdot g$ $a = 1250 \cdot V^2 / H$

F = fuerza de retardo [N] F_G = fuerza de peso [N] m = masa de carga [kg] a = retardo [m/s²] g = aceleración de la gravedad 9,81 [m/s²] V = velocidad H = longitud de carrera de amortiguador [mm]

Mini cuna, Serie MSC-HG-EE

R412018919

Cilindros
de guía
AVENTICS
serie MSC

2024-04-06

factor de corrección (a, d)

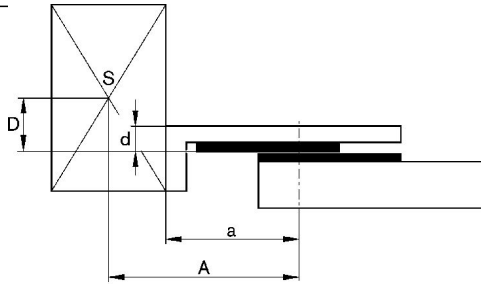

Masa móvil máxima

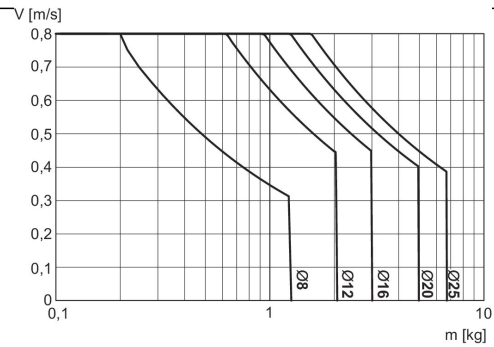

V = velocidad [m/s]
m = masa

Factor de corrección velocidad
necesaria de retracción y
extracción, horizontal

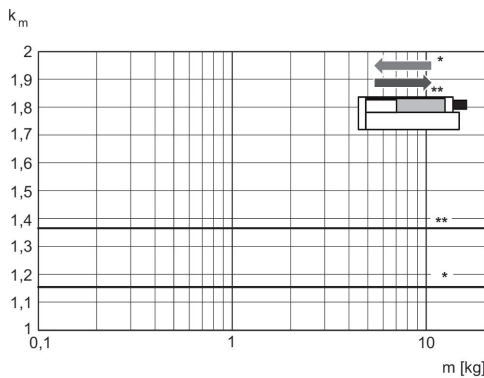

Factor de corrección velocidad
necesaria de extracción, vertical,
hacia abajo

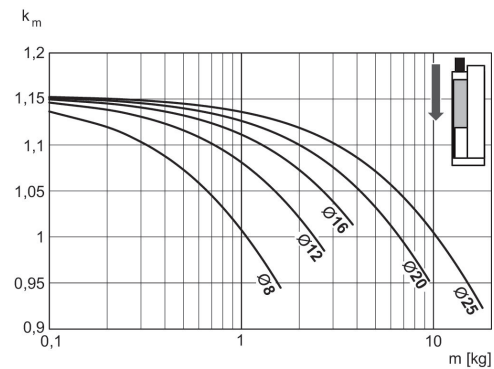

* en retracción
** en extracción
 $V = s/1000 \cdot t \cdot km$
V = velocidad [m/s]
S = carrera

$V = s/1000 \cdot t \cdot km$
V = velocidad [m/s]
S = carrera [mm]
t = tiempo [s] para una carrera
m = masa

Mini cuna, Serie MSC-HG-EE

R412018919

Cilindros
de guía
AVENTICS
serie MSC

2024-04-06

Factor de corrección velocidad
necesaria de retracción, vertical,
hacia abajo

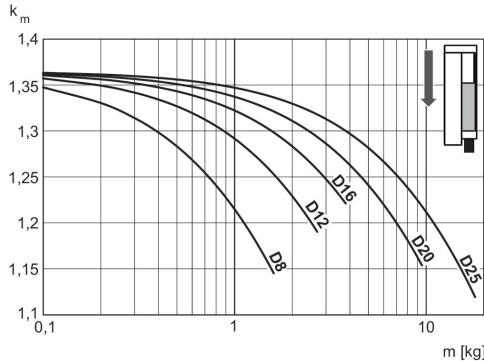

$V = s/1000 \cdot t \cdot km$
V = velocidad [m/s]
S = carrera [mm]
t = tiempo [s] para una carrera
m = masa

Factor de corrección velocidad
necesaria de retracción, vertical,
hacia arriba

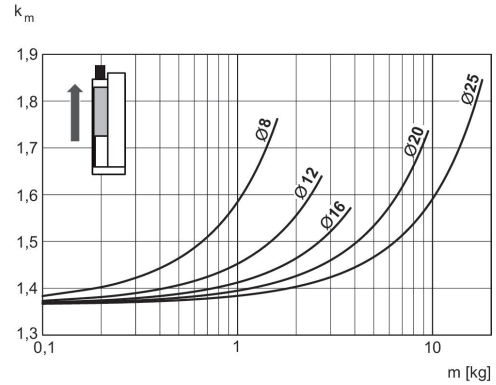

$V = s/1000 \cdot t \cdot km$
V = velocidad [m/s]
S = carrera [mm]
t = tiempo [s] para una carrera
m = masa

Factor de corrección velocidad
necesaria de extracción, vertical,
hacia arriba

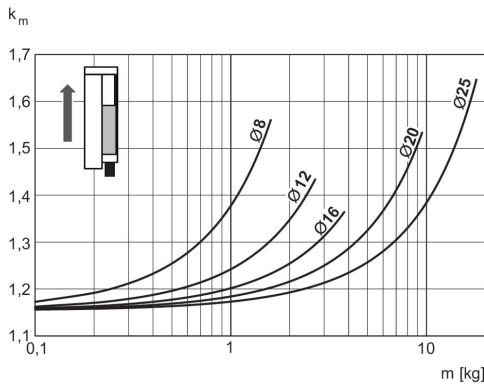

$V = s/1000 \cdot t \cdot km$
V = velocidad [m/s]
S = carrera [mm]
t = tiempo [s] para una carrera
m = masa

Velocidad de extracción máx.

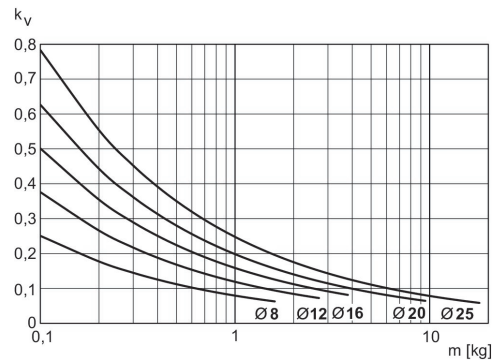

$V = \sqrt{s \cdot kv}$
V = velocidad [m/s]
S = carrera [mm]
m = masa

Capacidad de carga

Mini cuna, Serie MSC-HG-EE

R412018919

Cilindros
de guía
AVENTICS
serie MSC

2024-04-06

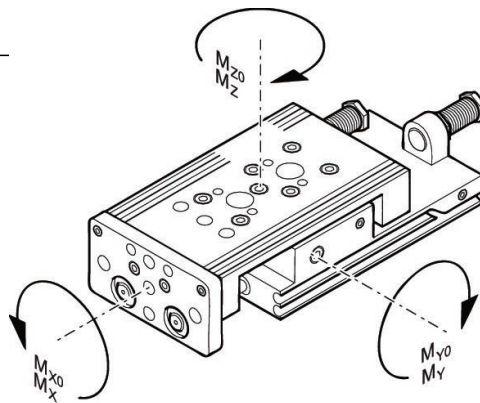

M = par de giro máx. admisible

factor de corrección (a)

N° de material	Ø del émbolo	Carrera	a [mm]	d [mm]	Mx0 par estático M [Nm]	My0 par estático M [Nm]	Mz0 par estático M [Nm]	Mx par dinámico M [Nm]	My par dinámico M [Nm]
R412019204	8	10	45	14	7	7	7	1.1	1.9
R412019205	8	20	50	14	7	7	7	1.1	1.9
R412019206	8	30	60	14	7	7	7	1.1	1.9
R412019207	8	40	70	14	7	7	7	1.1	1.9
R412019208	8	50	80	14	9	13	13	1.3	2.9
R412019209	8	80	125	14	13	25	25	1.3	3.8
R412019190	12	10	54.5	16	20	14	14	4.2	4.4
R412019191	12	20	59.5	16	20	14	14	4.2	4.4
R412019192	12	30	64.5	16	20	14	14	4.2	4.4
R412019193	12	40	74.5	16	20	14	14	4.2	4.4
R412019194	12	50	84.5	16	23	19	19	4.6	5.6
R412019195	12	80	125	16	33	32	32	5.2	8.2
R412019196	12	100	145	16	33	32	32	5.2	8.2
R412019168	16	10	55.5	15	35	25	25	6.5	6.6
R412019169	16	20	60.5	15	35	25	25	6.5	6.6
R412019170	16	30	65.5	15	35	25	25	6.5	6.6
R412019171	16	40	75.5	15	35	25	25	6.5	6.6
R412019172	16	50	85.5	15	38	29	29	7	7.6
R412019173	16	80	126	15	74	58	58	8.7	12.8
R412019174	16	100	146	15	74	58	58	8.7	12.8
R412019175	16	125	198.5	15	88	118	118	15.2	31.2
R412019176	16	150	223.5	15	88	119	119	15.2	31.2
R412018910	20	10	60.5	20	87	57	57	9.6	12
R412018911	20	20	65.5	20	87	57	57	9.6	12
R412018912	20	30	70.5	20	87	57	57	9.6	12
R412018913	20	40	80.5	20	87	57	57	9.6	12
R412018914	20	50	90.5	20	93	65	65	10	13.3
R412018915	20	80	130.5	20	116	99	99	11.7	19
R412018916	20	100	150.5	20	116	99	99	11.7	19

Mini cuna, Serie MSC-HG-EE

R412018919

Cilindros
de guíado
AVENTICS
serie MSC

N° de material	Ø del émbolo	Carrera	a [mm]	d [mm]	Mx0 par estático M [Nm]	My0 par estático M [Nm]	Mz0 par estático M [Nm]	Mx par dinámico M [Nm]	My par dinámico M [Nm]
R412018917	20	125	201	20	126	136	136	19	40.6
R412018918	20	150	233.5	20	126	152	152	19	45.4
R412018919	20	200	296	20	126	179	179	19	53.4
R412019023	25	10	67.5	24	100	90	90	22.9	19.5
R412019024	25	20	72.5	24	100	90	90	22.9	19.5
R412019025	25	30	77.5	24	100	90	90	22.9	19.5
R412019026	25	40	87.5	24	100	90	90	22.9	19.5
R412019027	25	50	96.5	24	100	90	90	15.3	13
R412019028	25	80	137	24	110	129	129	18.8	20.8
R412019029	25	100	157	24	110	129	129	18.8	20.8
R412019030	25	125	201	24	145	180	180	20.4	44.1
R412019031	25	150	236.5	24	145	201	201	20.4	49.2
R412019032	25	200	299	24	145	236	236	20.4	57.8

N° de material	Mz par dinámico M [Nm]
R412019204	1.9
R412019205	1.9
R412019206	1.9
R412019207	1.9
R412019208	2.9
R412019209	3.8
R412019190	4.4
R412019191	4.4
R412019192	4.4
R412019193	4.4
R412019194	5.6
R412019195	8.2
R412019196	8.2
R412019168	6.6
R412019169	6.6
R412019170	6.6
R412019171	6.6
R412019172	7.6
R412019173	12.8
R412019174	12.8
R412019175	31.2
R412019176	31.2
R412018910	12
R412018911	12
R412018912	12
R412018913	12
R412018914	13.3
R412018915	19
R412018916	19
R412018917	40.6
R412018918	45.4

Mini cuna, Serie MSC-HG-EE

R412018919

Cilindros
de guíado
AVENTICS
serie MSC

2024-04-06

N° de material	Mz par dinámico M [Nm]
R412018919	53.4
R412019023	19.5
R412019024	19.5
R412019025	19.5
R412019026	19.5
R412019027	13
R412019028	20.8
R412019029	20.8
R412019030	44.1
R412019031	49.2
R412019032	57.8

Plano de vista general

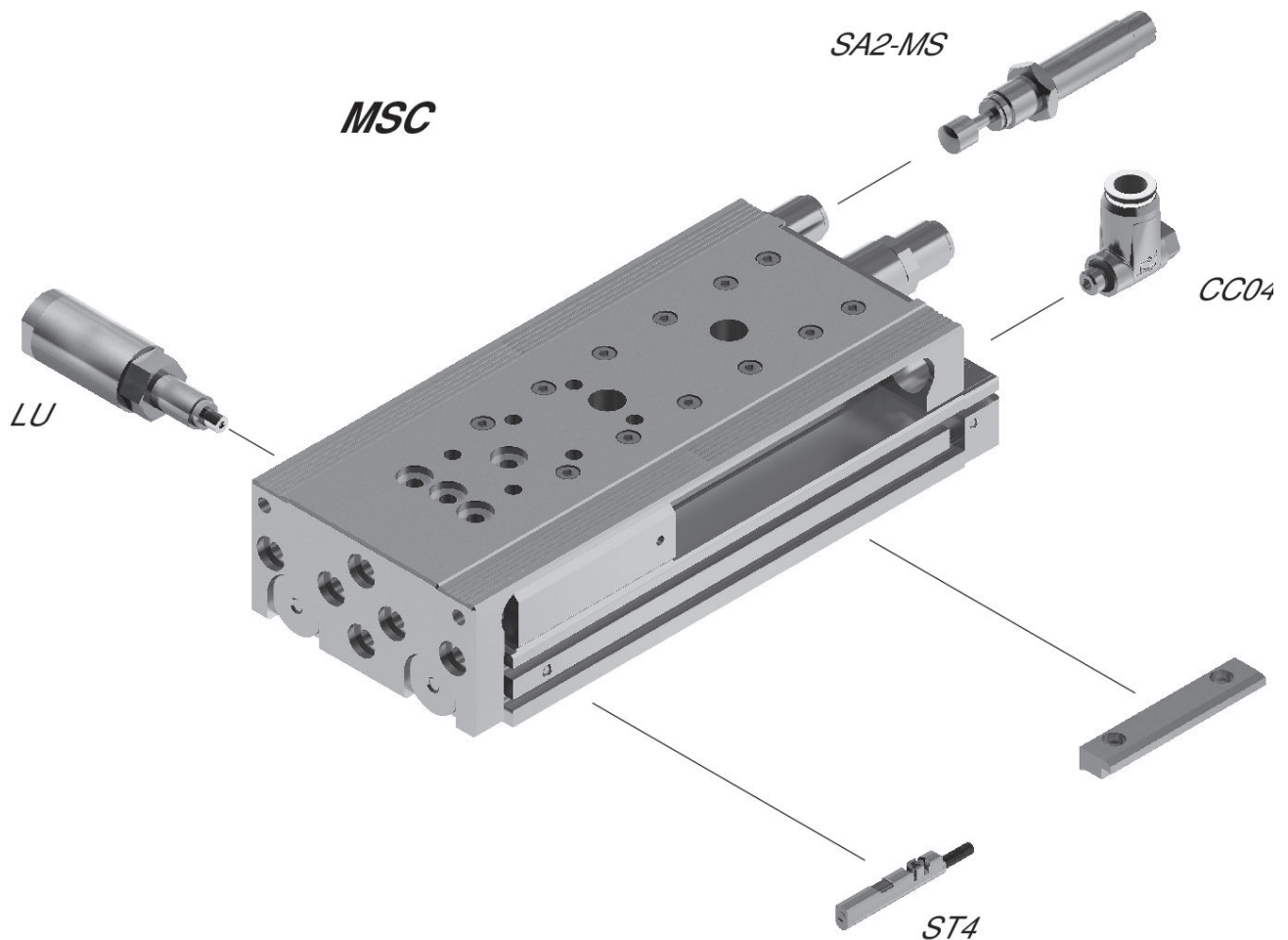

INDICACIÓN: Este plano de vista general sirve como orientación para saber en qué lugares pueden fijarse al cilindro los diferentes accesorios. Para ello se ha simplificado la representación. En consecuencia, no está permitido hacer deducciones concretas sobre datos de medidas.

Mini cuna, Serie MSC-HG-EE

R412018919

Cilindros
de guado
AVENTICS
serie MSC

2024-04-06

Peso de las piezas móviles [kg]

Ø del émbolo	S=10	S=20	S=30	S=40	S=50	S=80	S=100	S=125	S=150
8	0.14	0.14	0.155	0.165	0.195	0.265	–	–	–
12	0.255	0.255	0.26	0.28	0.315	0.403	0.46	–	–
16	0.375	0.375	0.375	0.4	0.45	0.615	0.65	0.725	0.765
20	0.655	0.655	0.655	0.69	0.765	0.985	1.035	1.2	1.29
25	1	1	1	1.1	1.225	1.45	1.625	1.885	2.085

Ø del émbolo	S=200
8	–
12	–
16	–
20	1.54
25	2.445