

AVENTICS Series CL03-EV Directional valves

The AVENTICS Series CL03-EV spool valves are hygienically designed. They easily resist wet cleaning with aggressive cleaning detergents. The Series complies with protection class IP69K, is suitable for class NSF-H1 lubricants and designed for intensive application in the food and beverage industry.

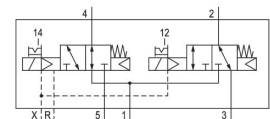

Technical data

Industry	Industrial
Activation	Electrically
Valve type	Spool valve, positive overlapping
Switching principle	2x 3/2 NO/NC, with spring return
Valve function	NO/NC
Sealing principle	Soft seal
Connection type	Plate connection
Manual override	with detent
Compressed air connection input	G 1/8
Compressed air connection output	G 1/8
Compressed air connection, exhaust	G 1/8
Pilot control exhaust	With collective pilot air exhaust
Compressed air connection pilot input	M5
Compressed air connection pilot exhaust	M5
Nominal flow Qn	700 l/min
Flow conductance b	0.22
Flow conductance C	2.9 l/(s*bar)

2x3/2-directional valve, Series CL03-EV

2024-04-02

R412017961

Min. working pressure	-0.9 bar
Max. working pressure	10 bar
Min. control pressure	3 bar
Max. control pressure	10 bar
Protection class with connection	IP65 IP67 IP69K
Protective circuit	Z-diode
Reverse polarity protection	Protected against polarity reversal
Operational voltage	24 V DC
Operational voltage DC	24 V
Voltage tolerance DC	-15% / +20%
Pilot	External
Pilot valve width	16 mm
LED status display	Yellow
Power consumption DC	0.35 W
Duty cycle	100 %
Typ. switch-on time	16 ms
Typ. switch-off time	25 ms
Blocking principle	Single base plate principle
suitable for use in food processing	suitable for use in food processing
Certificates	UR (Underwriters Laboratories)
Min. ambient temperature	0 °C
Max. ambient temperature	50 °C
Min. medium temperature	0 °C
Max. medium temperature	50 °C
Medium	Compressed air
Min. oil content of compressed air	0 mg/m ³
Max. oil content of compressed air	5 mg/m ³
Max. particle size	5 µm
Mounting screws	M5
Mounting screw tightening torque	2 Nm
Tightening torque tolerance	±0,2 mT
Weight	0.165 kg

Material

Housing material	Polyamide fiber-glass reinforced
Seal material	Hydrogenated acrylonitrile butadiene rubber
Part No.	R412017961

Technical information

For series QR2 fittings, see "Pneumatic connection technologies".

The inner valve can be replaced by all series CL03 valves described under "Valve systems".

The pilot valve is UL (Underwriters Laboratories) certified.

The min. control pressure must be adhered to, since otherwise faulty switching and valve failure may result!

The pressure dew point must be at least 15 °C less than ambient and medium temperature and may not exceed 3 °C.

The oil content of compressed air must remain constant during the life cycle.

Use only the approved oils from AVENTICS. Further information can be found in the "Technical information" document (available in <https://www.emerson.com/en-us/support>).

2x3/2-directional valve, Series CL03-EV

2024-04-02

R412017961

Dimensions

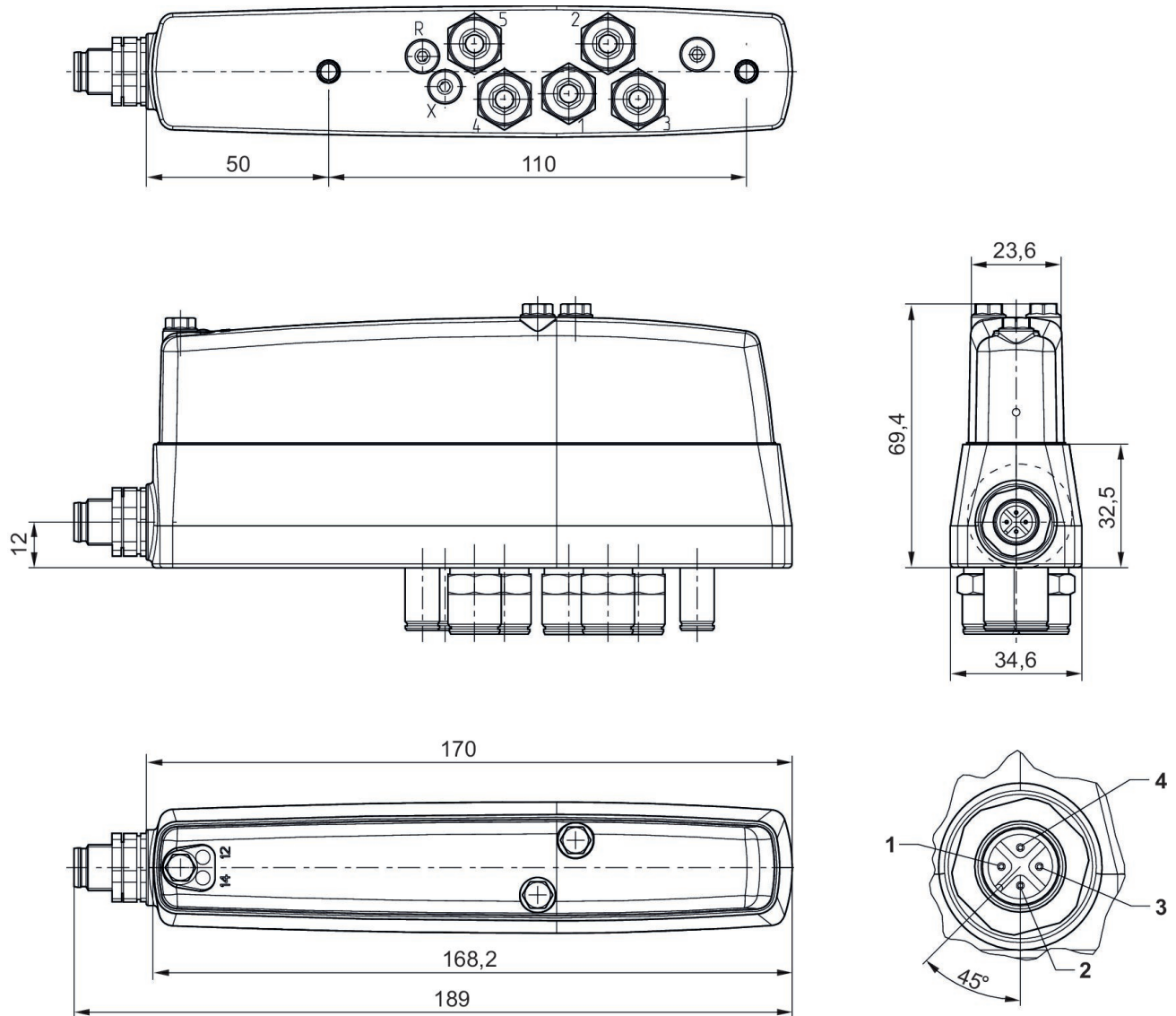

Electrical connection:

1) Not connected 2) Solenoid 12 3) 0 V 4) Solenoid 14