

5/2-directional valve, Series CD04

2023-09-07

R412012840

Series CD04

Qn max. 900 l/min

3/2, 5/2, 5/3 spool valves with metal housing

For demanding environments

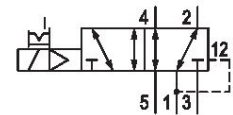

Technical data

Industry

Industrial

Activation

Electrically

Valve type

Spool valve, positive overlapping

Switching principle

5/2, with air spring return

Actuating control

Single Solenoid

Sealing principle

soft seal

Connection type

Pipe connection

Manual override

with detent

Standard compressed air connection

according to ANSI B1.20.3

Compressed air connection input

1/8-27 PTF

Compressed air connection output

1/8-27 PTF

Compressed air connection, exhaust

1/8-27 PTF

Compressed air connection pilot exhaust

M5

Nominal flow Qn

900 l/min

Nominal flow Qn 1 to 2

900 l/min

Nominal flow Qn 2 to 3

900 l/min

5/2-directional valve, Series CD04

2023-09-07

R412012840

Working pressure min.	3 bar
Working pressure max	10 bar
Control pressure min.	3 bar
Control pressure max.	10 bar
Electrical connection type	Plug
Electrical connection size	EN 175301-803, form B
Electrical connection number of poles	3-pin
Connector standard	EN 175301-803:2006
Protection class with connection	IP65
Operational voltage	12 V DC
DC operating voltage	12 V
Voltage tolerance DC	-10% / +10%
Pilot	Internal
Coil width	22 mm
Pilot valve width	26 mm
Compatibility index	14
Power consumption DC	4.6 W
Duty cycle	100 %
Typ. switch-on time	12 ms
Typ. switch-off time	21 ms
Min. ambient temperature	-15 °C
Max. ambient temperature	50 °C
Min. medium temperature	-15 °C
Max. medium temperature	50 °C
Medium	Compressed air
Oil content of compressed air min.	0 mg/m ³
Oil content of compressed air max.	1 mg/m ³
Max. particle size	50 µm
Mounting on manifold strip	P-strip
Weight	0.38 kg
Material	
Housing material	Die cast zinc

5/2-directional valve, Series CD04

2023-09-07

R412012840

Seal material

Polyamide fiber-glass reinforced

Acrylonitrile butadiene rubber

Part No.

R412012840

Technical information

The min. control pressure must be adhered to, since otherwise faulty switching and valve failure may result!

The pressure dew point must be at least 15 °C less than ambient and medium temperature and may not exceed 3 °C.

The oil content of compressed air must remain constant during the life cycle.

Use only the approved oils from AVENTICS. Further information can be found in the "Technical information" document (available in <https://www.emerson.com/en-us/support>).

Dimensions in inches

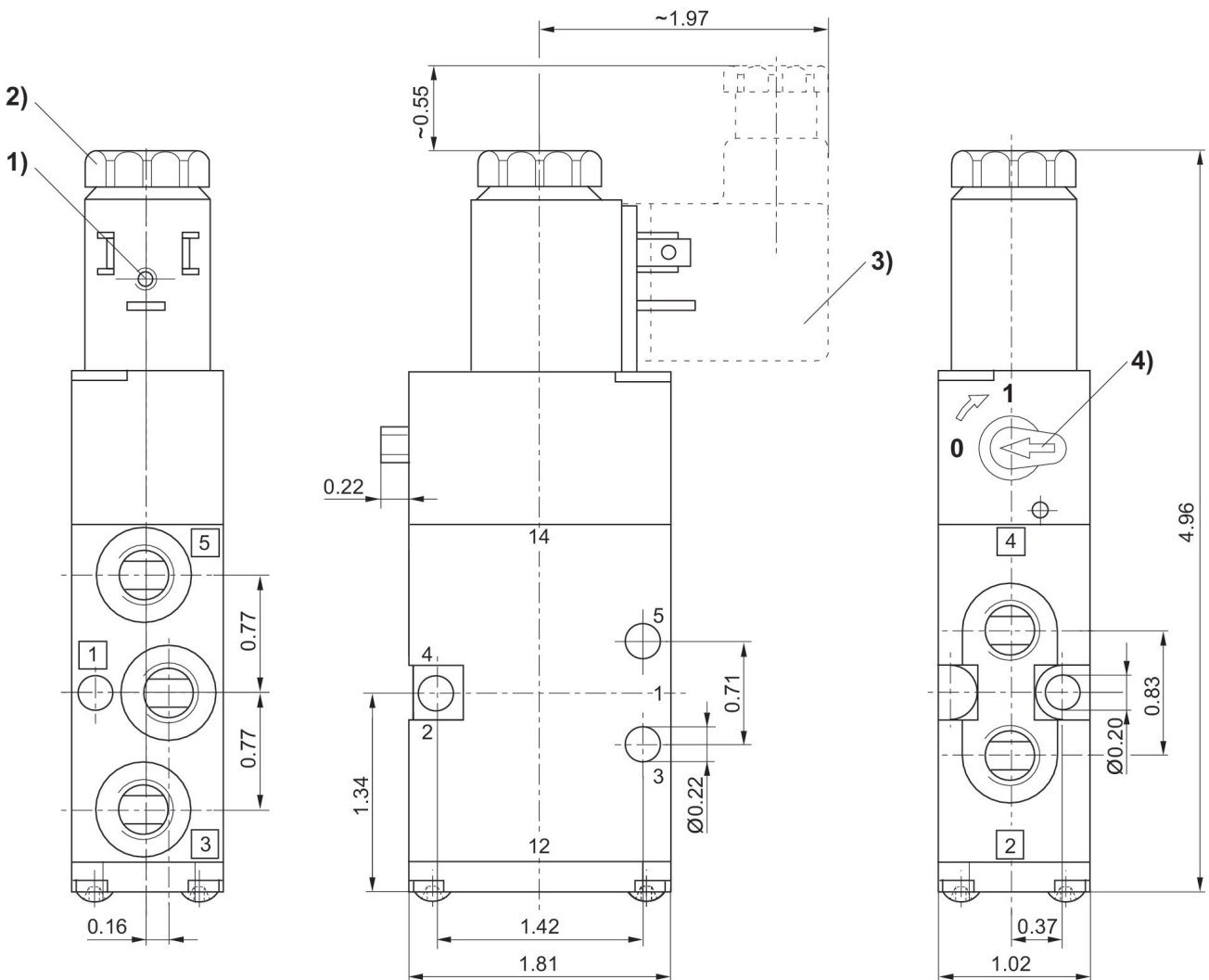

1) Coil can be rotated at 90° intervals

5/2-directional valve, Series CD04

2023-09-07

R412012840

- 2) After removal of cap M5 internal thread
- 3) Valve plug connector can be plugged at 180° intervals
- 4) Manual override