

Manifold strip

R412012677

2024-08-07



Technical data

Industry	Industrial
Type	Manifold strip
For series	TC08
Type	Manifold strip
Nominal flow Qn	800 l/min
Min. ambient temperature	-10 °C
Max. ambient temperature	50 °C
Medium	Compressed air
Max. number of valve positions	8
Weight	0.313 kg

Material

Material base plate	Aluminum
Seal material	Acrylonitrile butadiene rubber
Part No.	R412012677

Technical information

The min. control pressure must be adhered to, since otherwise faulty switching and valve failure may result!

The pressure dew point must be at least 15 °C less than ambient and medium temperature and may not exceed 3 °C.

The oil content of compressed air must remain constant during the life cycle.

Use only the approved oils from AVENTICS. Further information can be found in the "Technical information" document (available in <https://www.emerson.com/en-us/support>).

Manifold strip

2024-08-07

R412012677

Dimensions

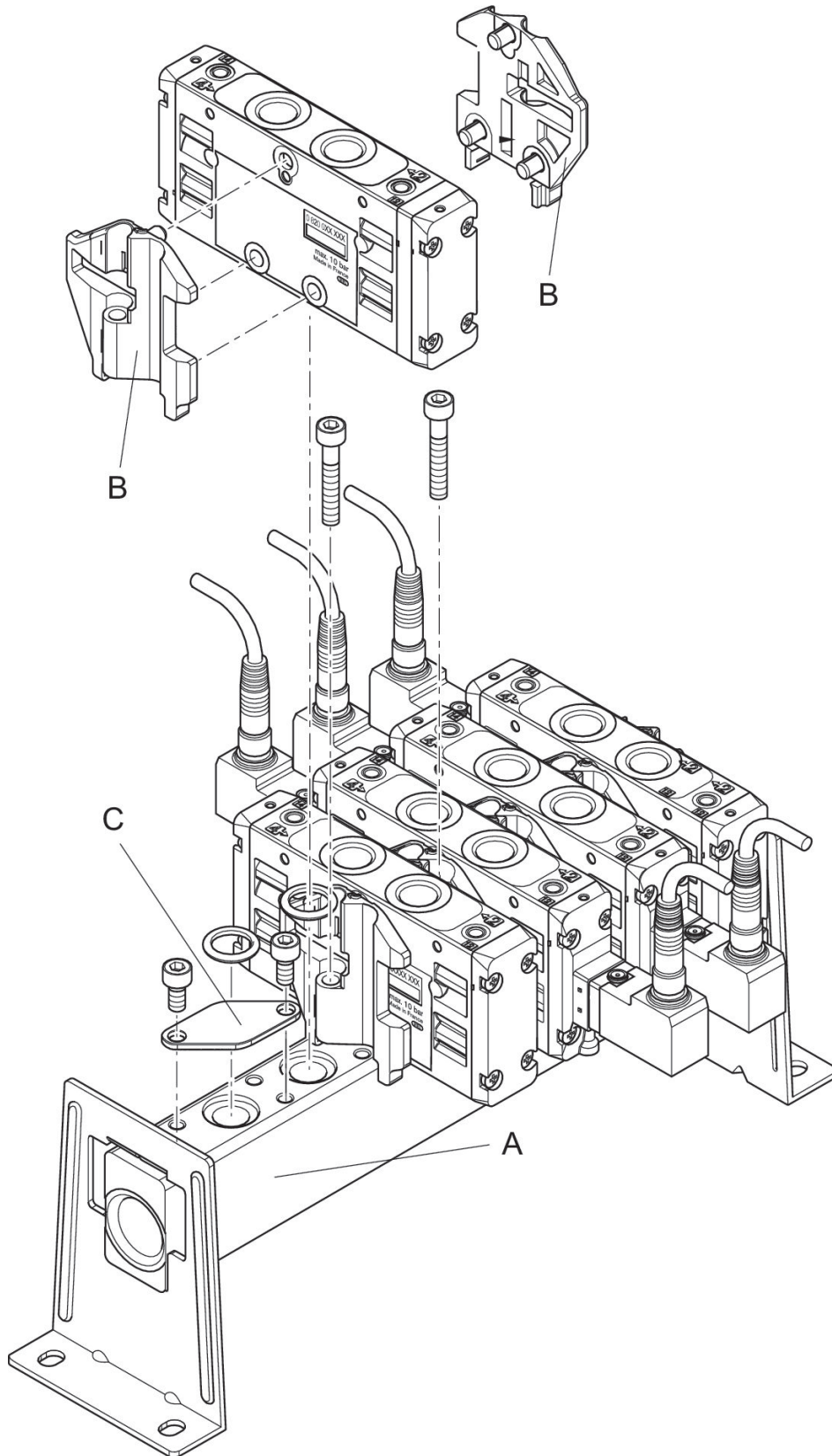

The following must be ordered to mount the valves: manifold strip A and mounting kit B
C = Blanking plate

Part No.	
R422000931	A
R422000932	A
R422000933	A
R422000934	A
R422000935	A
R412012677	A
R412012678	A
R412012679	A
R422000937	B

Dimensions

P-strip with mounting bracket

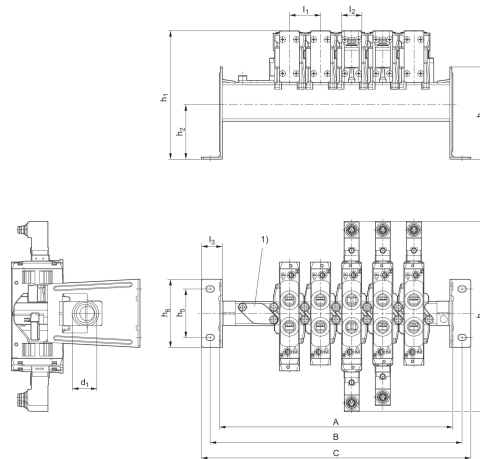

1) Blanking plate

Part No.	n	A	B	C	d1	h1	h2	h3	h4
R422000931	2	90.4	108.4	123.4	G 3/8	102,8	45,5	80	175,6
R422000932	3	116.4	134.4	149,4	G 3/8	102,8	45,5	80	175,6
R422000933	4	142.4	160.4	175,4	G 3/8	102,8	45,5	80	175,6
R422000934	5	168.4	186.4	201,4	G 3/8	102,8	45,5	80	175,6
R422000935	6	194.4	212.4	227,4	G 3/8	102,8	45,5	80	175,6
R412012677	8	246.4	264.4	279,4	G 3/8	102,8	45,5	80	175,6
R412012678	10	298,4	316,4	331,4	G 3/8	102,8	45,5	80	175,6

h5	h6	l1	l2	l3
44	60	26	16,8	19,5
44	60	26	16,8	19,5
44	60	26	16,8	19,5
44	60	26	16,8	19,5
44	60	26	16,8	19,5
44	60	26	16,8	19,5

Manifold strip

2024-08-07

R412012677

h5	h6	l1	l2	l3
44	60	26	16,8	19,5

n = number of valve positions

P-strip with mounting bracket

Dimensions

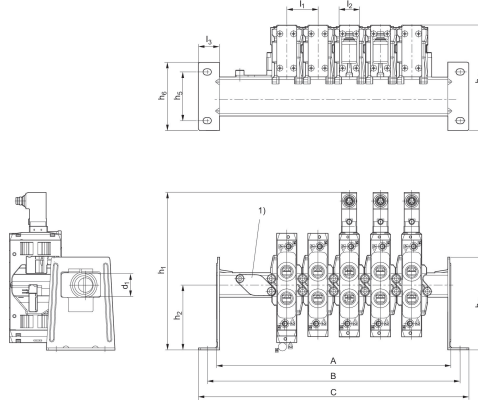

1) Blanking plate

Part No.	n	A	B	C	d1	h1	h2	h3	h4
R422000931	2	90,4	108,4	123,4	G 3/8	127,8	51,5	80	86,4
R422000932	3	116,4	134,4	149,4	G 3/8	127,8	51,5	80	86,4
R422000933	4	142,4	160,4	175,4	G 3/8	127,8	51,5	80	86,4
R422000934	5	168,4	186,4	201,4	G 3/8	127,8	51,5	80	86,4
R422000935	6	194,4	212,4	227,4	G 3/8	127,8	51,5	80	86,4
R412012677	8	246,4	264,4	279,4	G 3/8	127,8	51,5	80	86,4
R412012678	10	298,4	316,4	331,4	G 3/8	127,8	51,5	80	86,4

h5	h6	l1	l2	l3
44	60	26	16,8	19,5
44	60	26	16,8	19,5
44	60	26	16,8	19,5
44	60	26	16,8	19,5
44	60	26	16,8	19,5
44	60	26	16,8	19,5
44	60	26	16,8	19,5

n = number of valve positions

p-strip with support bracket

Dimensions

Manifold strip

2024-08-07

R412012677

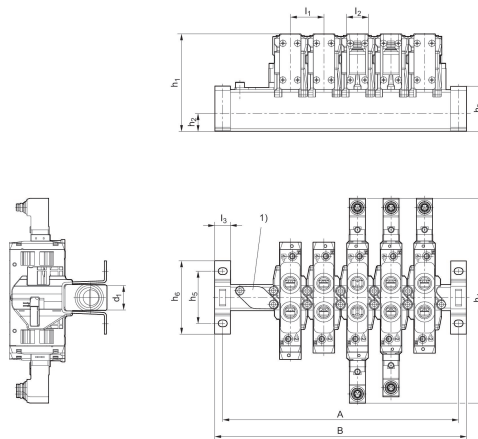

1) Blanking plate

Part No.	n	A	B	d1	h1	h2	h3	h4	h5
R422000931	2	76,4	90,4	G 3/8	70,8	13,5	33,5	175,6	44
R422000932	3	102,4	116,4	G 3/8	70,8	13,5	33,5	175,6	44
R422000933	4	128,4	142,4	G 3/8	70,8	13,5	33,5	175,6	44
R422000934	5	154,4	168,4	G 3/8	70,8	13,5	33,5	175,6	44
R422000935	6	180,4	194,4	G 3/8	70,8	13,5	33,5	175,6	44
R412012677	8	232,4	246,4	G 3/8	70,8	13,5	33,5	175,6	44
R412012678	10	284,4	298,4	G 3/8	70,8	13,5	33,5	175,6	44

h6	l1	l2	l3
58	26	16,8	14
58	26	16,8	14
58	26	16,8	14
58	26	16,8	14
58	26	16,8	14
58	26	16,8	14
58	26	16,8	14

n = number of valve positions