

5/2-directional valve, Series CD12

R412008096

General series information Series CD12

- The AVENTICS Series CD consists of various spool valves with an extremely durable die-cast zinc housing. Its electrical, pneumatic, or mechanical actuating controls (roller, lever, pedal, or plunger) make the Series CD ideal for applications in harsh environments.

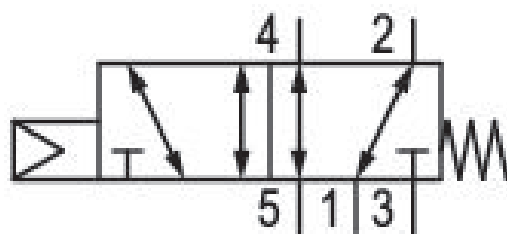

Technical data

Industry
Industrial

Activation
Electrically

Nominal flow Q_n
4100 l/min

Switching principle
5/2

Compressed air connection output
G 1/2

Working pressure min.
2 bar

Working pressure max
10 bar

Electrical connection type
Plug

Electrical connection size
EN 175301-803, form A

Electrical connection number of poles
3-pin

Actuating control
Single Solenoid

Sealing principle
Soft Seal

Pilot
Internal

ATEX
ATEX optional

Pilot valve width

30 mm

Valve type

Spool valve, positive overlapping

basic valve with electrical connector

Basic valve without coil

Connection type

Pipe connection

Return

With spring return

Control pressure min.

2 bar

Control pressure max.

10 bar

Min. ambient temperature

-15 °C

Max. ambient temperature

50 °C

Min. medium temperature

-15 °C

Max. medium temperature

50 °C

Medium

Compressed air

Max. particle size

50 µm

Oil content of compressed air min.

0 mg/m³

Oil content of compressed air max.

1 mg/m³

Standard compressed air connection

according to ISO 228-1

Compressed air connection input

G 1/2

Compressed air connection, exhaust

G 1/2

Pilot control exhaust

with directional pilot air exhaust

Compatibility index

13

14

Duty cycle

100 %

Pilot valve width

30 mm

Weight

0.85 kg

Housing material

Aluminum

Polyamide fiber-glass reinforced

Polyurethane

Part No.

R412008096

Seal material

Acrylonitrile butadiene rubber

Technical information

ATEX optional: ATEX version can be produced by combining the basic valve without coil with an ATEX coil. ATEX ID: see ATEX coils catalog page.

*Note: Basic valves feature a maximum working pressure of 16 bar. When combined with standard CNOMO pilots, the maximum working pressure is 10 bar.

The min. control pressure must be adhered to, since otherwise faulty switching and valve failure may result!

The pressure dew point must be at least 15 °C under ambient and medium temperature and may not exceed 3 °C .

The oil content of compressed air must remain constant during the life cycle.

Use only the approved oils from AVENTICS. Further information can be found in the "Technical information" document (available in <https://www.emerson.com/en-us/support>).

Dimensions

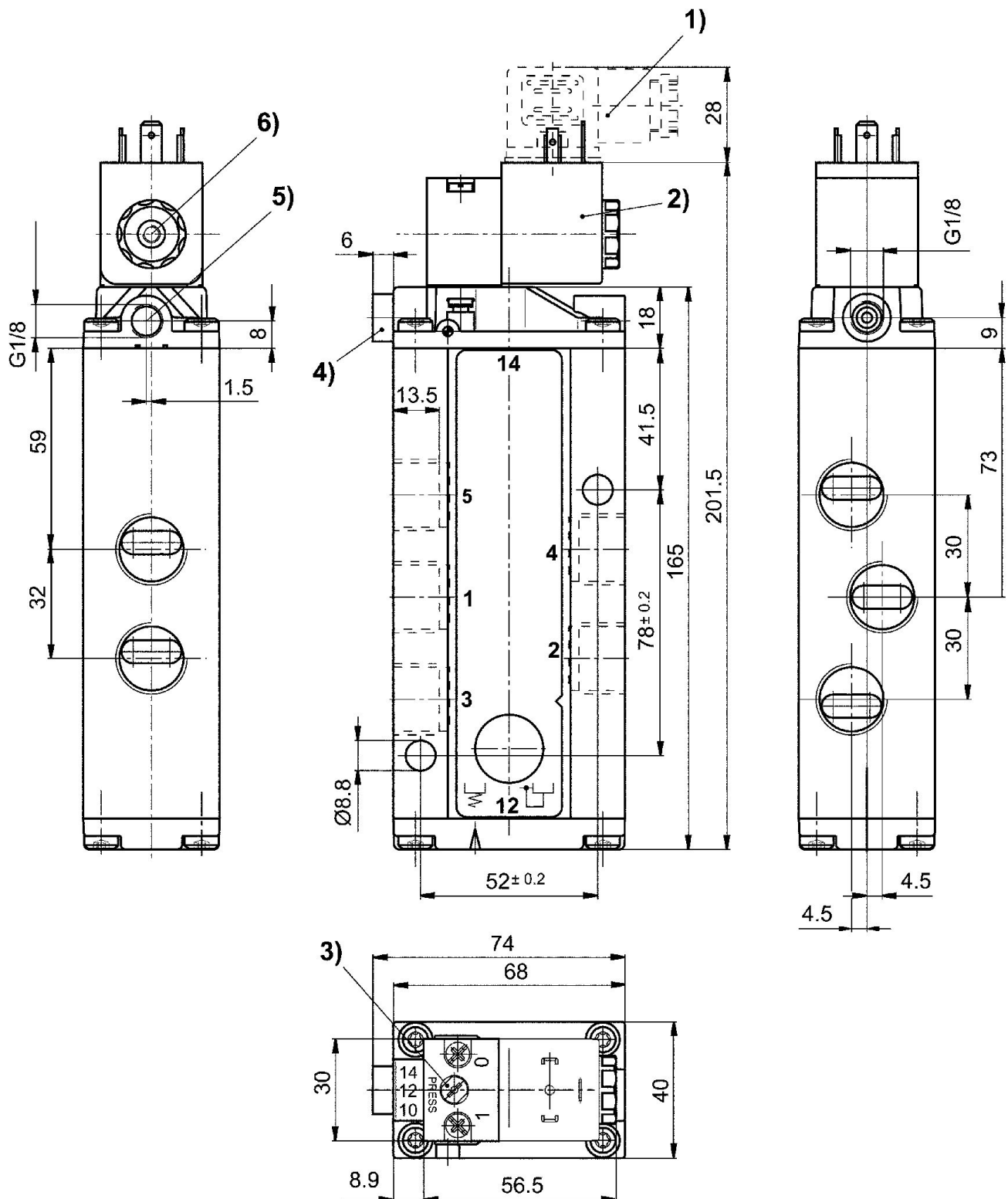

- 1) Valve plug connector 2) Coil can be rotated at 90° intervals 3) Manual override
4) Port X (only for externally piloted valves) 5) Exhaust port of piston 6) Pilot valve exhaust, M5