

Series DDL

The AVENTICS Series DDL allows for a flexible fieldbus strategy and extended diagnostic functionality. Extended diagnostic functionality up to the pilot valve provides detailed information in case of an error. I/O-modules and E/P pressure regulators complete the product portfolio.



Technical data

Industry	Industrial
Note	M8x1, M12x1
Signal connection E/A type	Socket (female)
Signal connection E/A thread size	M12
Signal connection E/A number of poles	5-pin
Signal connection E/A coding	A-coded
Fieldbus design	B-design
Min. ambient temperature	0 °C
Max. ambient temperature	50 °C
Operational voltage electronics	24 V DC
Protection class	IP65
Weight	0.47 kg

Material

Housing material	Die-cast aluminum
Part No.	R412000871

Technical information

Max. 6 input or 6 output modules may be used.

You will find assignment schemes for the product in the operating instructions, or contact the nearest AVENTICS sales office.

Fig. 2

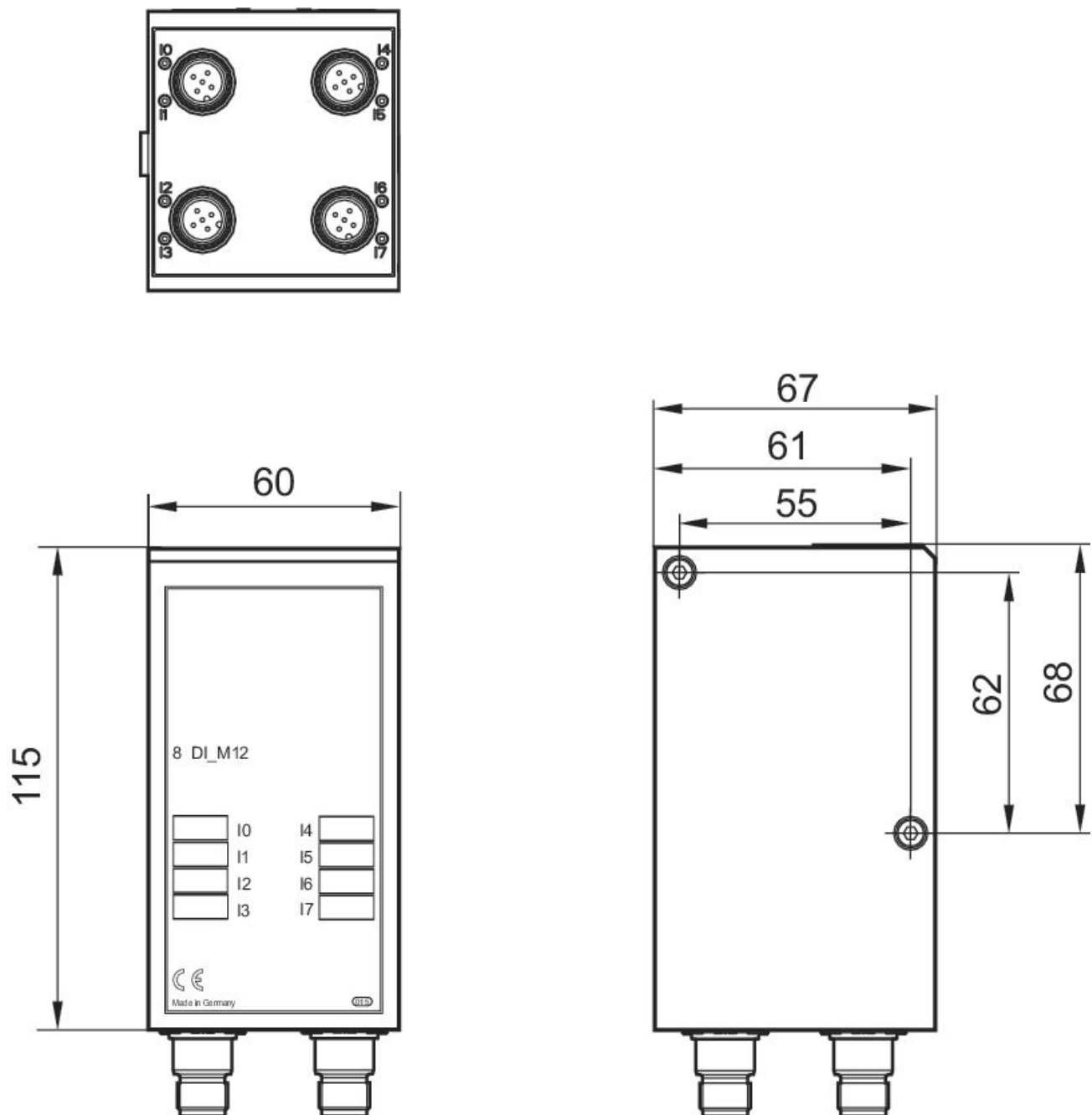

Fig. 1

