

Fissaggio a flangia, Serie MF1, MF2

7472ZZ1409

Fissaggi a
flangia

2023-11-14

Montajes de brida AVENTICS

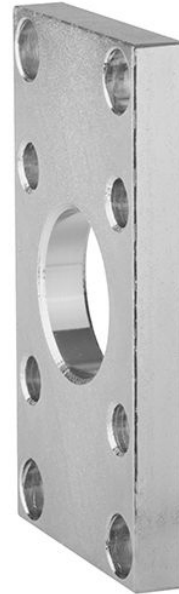

Dati tecnici

Settore

Industria

Diametro pistone

200 mm

Ø cuscinetto oscillante

30 mm

Materiale

Materiale corpo

Acciaio, cromato

Superficie Corpo

zincato

Codice

7472ZZ1409

Dimensioni

Fissaggio a flangia, Serie MF1, MF2

7472ZZ1409

Fissaggi a
flangia

2023-11-14

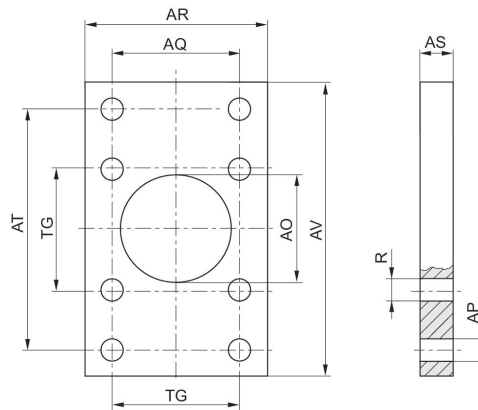

Ø pistone	Codice	AO H11	AP H13	AQ JS14	AR	AS	AT JS14	AV	R
25	1827005926	25	9	28	40	8	68	80	7
32	1827005927	25	9	33	45	8	68	80	7
40	1827005928	32	9	40	52	8	78	90	7
50	1827005929	32	11	49	65	10	94	110	9
63	1827005930	45	11	59	75	10	104	120	9
80	1827005931	45	14	75	95	12	130	150	11
100	1827005932	55	14	90	115	12	150	170	11
125	1827005933	55	18	110	140	16	180	205	14
160	7472ZZ1408	65	22	140	180	20	228	260	18
200	7472ZZ1409	65	22	175	220	20	268	300	18

Ø pistone	TG
25	28
32	33
40	40
50	49
63	59
80	75
100	90
125	110
160	140
200	175