

5811111710

AVENTICS Series 581 - Size 1 Standardized valves

The AVENTICS series 581 complies with the ISO 5599-1 valve standard. Due to the high degree of modularity, the series offers all valve functions, integrated throttle valves, various pilot coils and an extensive range of accessories. Qn = 950 ... 1400 l/min

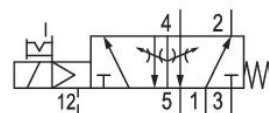

Technical data

| | |
|---------------------------------------|-------------------------|
| Industry | Industrial |
| Activation | Electrically |
| Nominal flow Qn | 1400 l/min |
| Switching principle | 5/2, with spring return |
| Compressed air connection output | Base plate ISO 5599-1 |
| Min. working pressure | -0.95 bar |
| Max. working pressure | 10 bar |
| Operational voltage | 24 V DC |
| Operational voltage DC | 24 V |
| Voltage tolerance DC | -10% / +10% |
| Manual override | without detent |
| Electrical connection type | Plug |
| Electrical connection size | M12 |
| Electrical connection number of poles | 4-pin |
| Actuating control | Single Solenoid |
| Sealing principle | Soft seal |
| Pilot | Internal |
| Standards | ISO 5599-1 |
| Pilot valve width | 22 mm |

5/2-directional valve, Series 581, size 1

2023-11-28

5811111710

| | |
|---|----------------------------------|
| Valve type | Spool valve |
| Blocking principle | Single base plate principle |
| Connection type | Plate connection |
| Return | With spring return |
| Compressed air connection input | Base plate ISO 5599-1 |
| Compressed air connection, exhaust | Base plate ISO 5599-1 |
| Compressed air connection pilot exhaust | M5 |
| Power consumption DC | 0.35 W |
| Flow conductance C | 5.2 l/(s*bar) |
| Throttle | with throttle |
| Frame size | ISO 1 |
| Min. control pressure | 3 bar |
| Max. control pressure | 10 bar |
| Min. ambient temperature | 0 °C |
| Max. ambient temperature | 50 °C |
| Min. medium temperature | 0 °C |
| Max. medium temperature | 50 °C |
| Medium | Compressed air |
| Max. particle size | 5 µm |
| Min. oil content of compressed air | 0 mg/m ³ |
| Max. oil content of compressed air | 5 mg/m ³ |
| Protection class with connection | IP65 |
| Duty cycle | 100 % |
| Typ. switch-on time | 12 ms |
| Typ. switch-off time | 25 ms |
| Mounting screws | with hexagon socket |
| Mounting screw tightening torque | 2 Nm |
| Weight | 0.18 kg |
| Housing material | Polyamide fiber-glass reinforced |
| Seal material | Acrylonitrile butadiene rubber |
| Part No. | 5811111710 |

Technical information

Switch-on power: 1 W for 40 ms

The min. control pressure must be adhered to, since otherwise faulty switching and valve failure may result!

The pressure dew point must be at least 15 °C less than ambient and medium temperature and may not exceed 3 °C.

The oil content of compressed air must remain constant during the life cycle.

Use only the approved oils from AVENTICS. Further information can be found in the “Technical information” document (available in <https://www.emerson.com/en-us/support>).

5/2-directional valve, Series 581, size 1

2023-11-28

5811111710

Dimensions

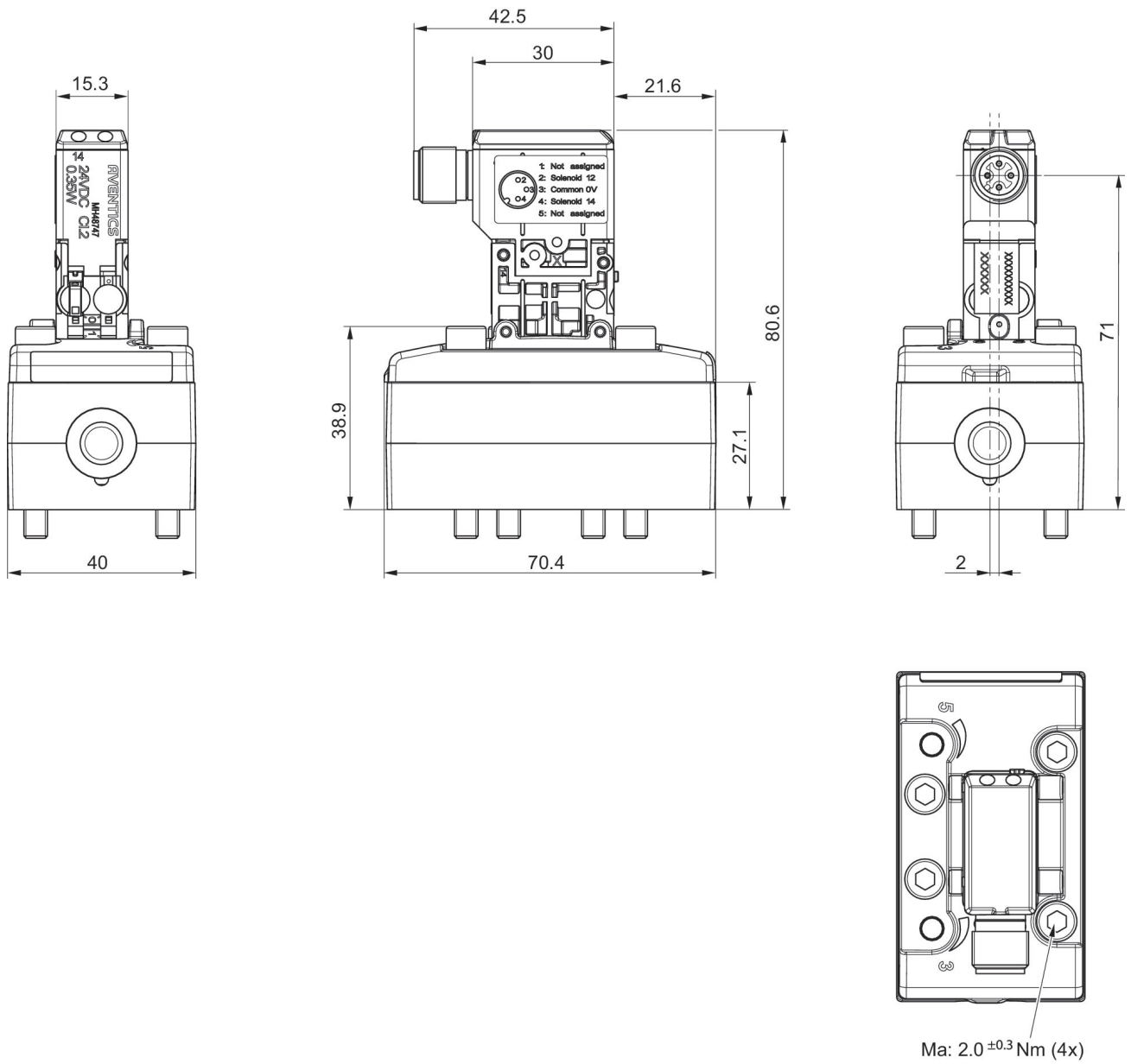

Pin assignments



-
- 1) not assigned
 - 2) Coil 12
 - 3) 0 V DC
 - 4) Coil 14