

3/2-directional valve, Series 579

5794425370

Series
490/579/589

2026-02-03

AVENTICS Series 490/579/589 Directional Control Valves

The AVENTICS Series 490/579/589 have a robust polymer housing that can be mounted individually or as a block. They cover a large range of voltages and feature fast connections for pneumatic tubing.

- Integrated connections
- Individual or block assemblies available
- Extensive voltage range
- Series suitable for dusty environments

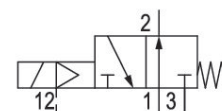

Technical data

Industry	Industrial
Activation	Electrically
Frame size	579
Valve type	Poppet valve
Switching principle	3/2, with spring return
Valve function	NO
Sealing principle	Soft seal
Connection type	Pipe connection

Compressed air connection input	Ø 1/4"
Compressed air connection output	Ø 1/4"

Min. working pressure	0.5 bar
Max. working pressure	8 bar
Min. control pressure	2 bar
Max. control pressure	8 bar

Protection class with connection	IP65
----------------------------------	------

3/2-directional valve, Series 579

5794425370

Series
490/579/589

2026-02-03

Reverse polarity protection	Protected against polarity reversal
Operational voltage	110 V AC
Operational voltage AC at 50 Hz	110 V
Operational voltage AC at 60 Hz	110 V
Voltage tolerance AC 60 Hz	-10 % / +15 %

Pilot	External
Coil width	20 mm
Holding power AC 50 Hz	3 VA
Holding power AC 60 Hz	2.4 VA
Switch-on power AC 50 Hz	4.2 VA
Switch-on power AC 60 Hz	3.4 VA

Duty cycle	100 %
Typ. switch-on time	18 ms
Typ. switch-off time	18 ms

Blocking principle	Single valve
Min. ambient temperature	-15 °C
Max. ambient temperature	50 °C
Min. medium temperature	-15 °C
Max. medium temperature	50 °C
Medium	Compressed air
Min. oil content of compressed air	0 mg/m ³
Max. oil content of compressed air	1 mg/m ³
Max. particle size	5 µm

Weight	0.093 kg
--------	----------

Material

Housing material	Polyamide
Seal material	Acrylonitrile butadiene rubber Polyurethane

Part No.	5794425370
----------	------------

Technical information

At an ambient temperature of $[[40]]$ °C the max. working pressure is $[[10]]$ bar].

Versions with voltage of less than 50 V DC do not have a protective ground.

The control pressure must be at least as high as the working pressure.

The min. control pressure must be adhered to, since otherwise faulty switching and valve failure may result!

The pressure dew point must be at least 15 °C less than ambient and medium temperature and may not exceed 3 °C.

The oil content of compressed air must remain constant during the life cycle.

Use only the approved oils from AVENTICS. Further information can be found in the “Technical information” document (available in <https://www.emerson.com/en-us/support>).

3/2-directional valve, Series 579

5794425370

Series
490/579/589

2026-02-03

Dimensions in inches

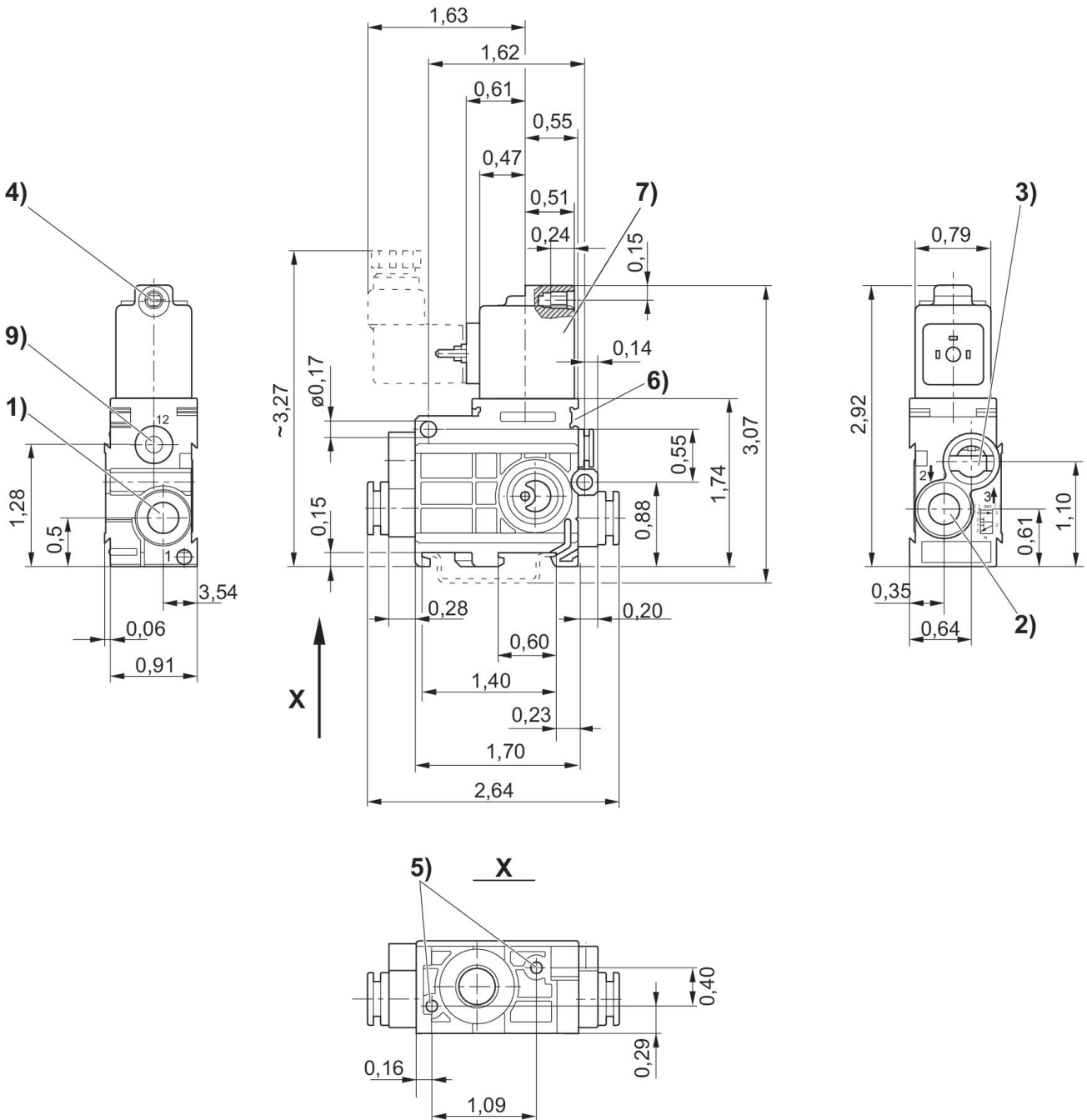

1) port 1 2) port 2 3) port 3 4) core Ø for M 5 5) pocket hole 6 mm deep for 3.5 self-tapping screw 6) manual override 7) Pilot valve 8) coil can be rotated at 180° intervals