

3/2-directional valve, Series 579

5791600010

Series 579, 589

■ $Q_n = [[520 \dots 850] \text{ l/min}]$

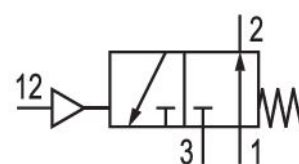
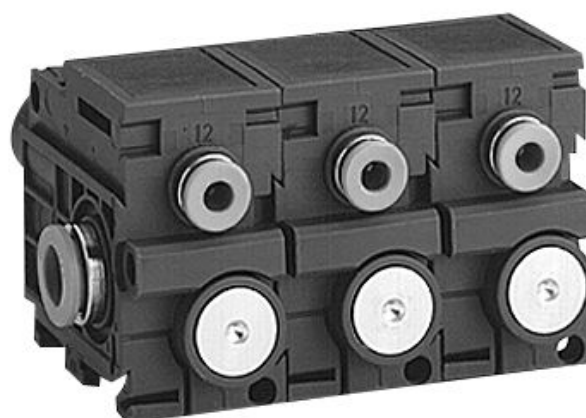

Technical data

Industry
Industrial

Activation
Pneumatically

Nominal flow Q_n
600 l/min

Switching principle
3/2

Return type
With spring return

Actuating control
Single Air Pilot

Compressed air connection output
 $\varnothing 8 \times 1$

Connection type
Pipe connection

Working pressure min.
0.5 bar

Working pressure max
8 bar

Sealing principle
Soft Seal

Valve type
Poppet valve

Can be assembled into blocks
Can be assembled into blocks

Blocking principle
Stacking valve

Blocking principle
Plate principle

Control pressure min.
2 bar

Min. ambient temperature
 $-15 \text{ }^\circ\text{C}$

Max. ambient temperature
 $60 \text{ }^\circ\text{C}$

Min. medium temperature
-15 °C

Max. medium temperature
60 °C

Medium
Compressed air

Max. particle size
5 µm

Oil content of compressed air min.
0 mg/m³

Oil content of compressed air max.
1 mg/m³

version pneumatic port
NO

Compressed air connection pilot exhaust
Ø 4

Weight
0.057 kg

Housing material
Polyamide

Seal material
Acrylonitrile butadiene rubber

Part No.
5791600010

Technical information

At an ambient temperature of [[40] °C] the max. working pressure is [[10] bar].

The min. control pressure must be adhered to, since otherwise faulty switching and valve failure may result!

The pressure dew point must be at least 15 °C under ambient and medium temperature and may not exceed 3 °C .

The oil content of compressed air must remain constant during the life cycle.

Use only the approved oils from AVENTICS. Further information can be found in the "Technical information" document (available in <https://www.emerson.com/en-us/support>).

Dimensions

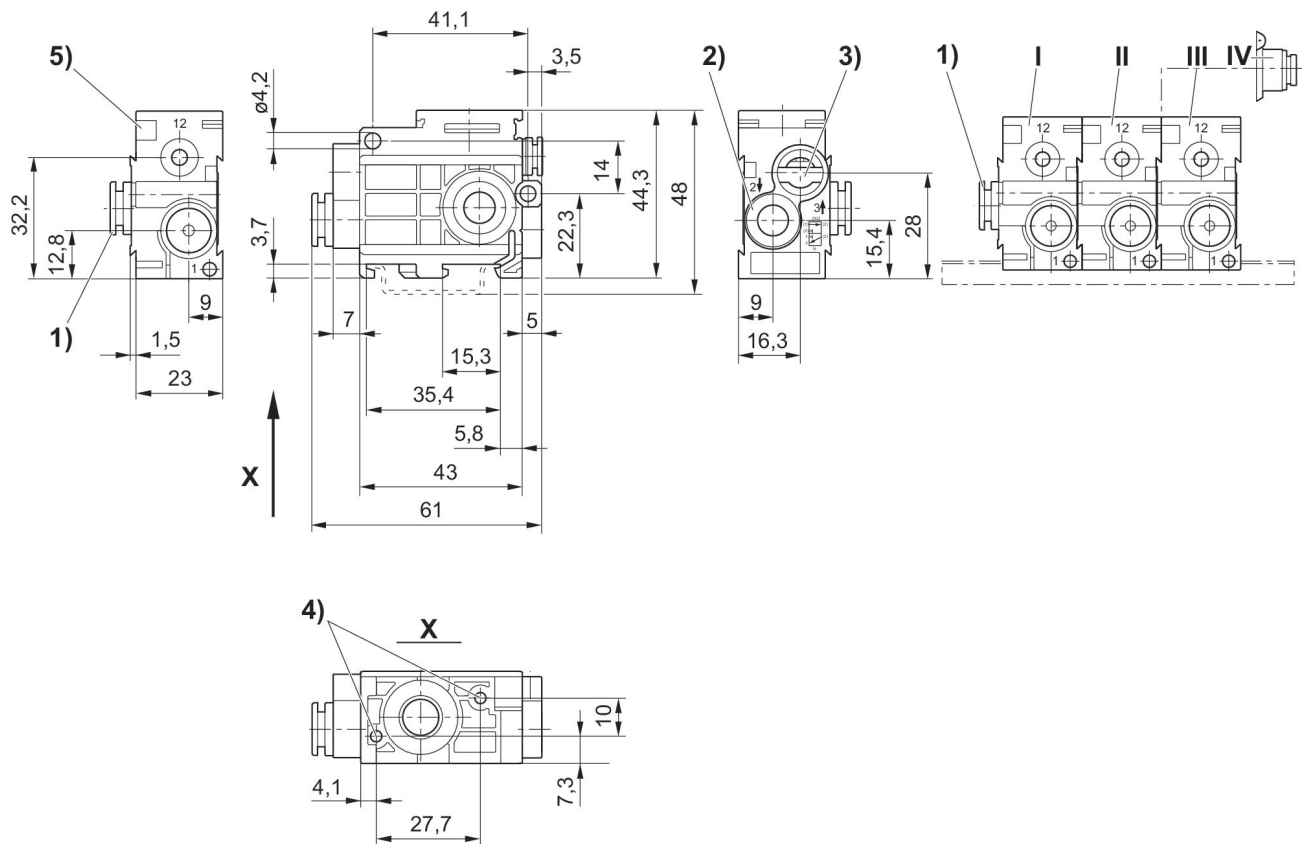

1) port 1 2) port 2 3) port 3 exhaust must not be throttled 4) pocket hole 6 mm deep for 3.5 self-tapping screw 5) mounting space for name plate * Air conn. module (item IV) mounted onto stacking valve (item II) permits additional air supply from right hand side. End valve (item III) not required. Inlet valve (pos. I)