

5/2-directional valve, Series CD07, single solenoid

5776085280

CD07

2025-12-08

AVENTICS Series CD07 Directional valves

The AVENTICS Series CD consists of various spool valves with an extremely durable die-cast zinc housing. Its electrical, pneumatic, or mechanical actuating controls (roller, lever, pedal, or plunger) make the Series CD ideal for applications in harsh environments.

For demanding environments

- Durable design
- Assembly on base plate
- Suitable for extreme ambient temperatures
- ATEX version available

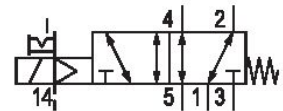
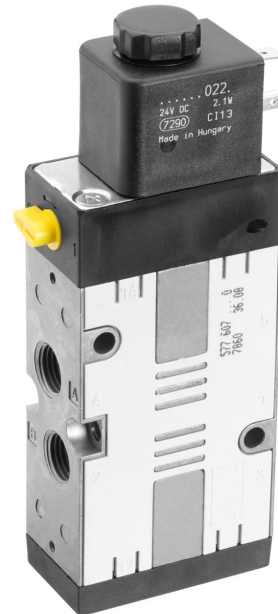

Technical data

Industry

Industrial

Activation

Electrically operated

Frame size

CD07

Valve type

Spool valve, positive overlapping

Switching principle

5/2, with spring return

Sealing principle

Soft seal

Connection type

Pipe connection

Manual override

with detent

Compressed air connection

G 1/4

Compressed air connection type

Internal thread

Standard compressed air connection

according to ISO 228-1

Compressed air connection input

G 1/4

Compressed air connection output

G 1/4

Compressed air connection, exhaust

G 1/4

Pilot control exhaust

with directional pilot air exhaust

Compressed air connection pilot input

G 1/8

Compressed air connection pilot exhaust

M5

5/2-directional valve, Series CD07, single solenoid

5776085280

CD07

2025-12-08

Nominal flow Qn	1200 l/min
Nominal flow Qn 1 to 2	1200 l/min
Nominal flow Qn 2 to 3	1200 l/min
Min. working pressure	-0.95 bar
Max. working pressure	10 bar
Min. control pressure	3 bar
Max. control pressure	10 bar
Electrical connection type	Plug
Electrical connection size	EN 175301-803, form A
Electrical connection number of poles	3-pin
Connector standard	EN 175301-803:2006
Protection class with connection	IP65
Reverse polarity protection	Protected against polarity reversal
Operational voltage	230 V AC
Operational voltage AC at 50 Hz	230 V
Voltage tolerance AC 50 Hz	-20 % / +10 %
Operational voltage AC at 60 Hz	230 V
Voltage tolerance AC 60 Hz	-10 % / +20 %
Pilot	External
Coil width	30 mm
Pilot valve width	30 mm
Compatibility index	52
Holding power AC 50 Hz	4.8 VA
Holding power AC 60 Hz	4.1 VA
Switch-on power AC 50 Hz	6.9 VA
Switch-on power AC 60 Hz	5.8 VA
Duty cycle	100 %
Typ. switch-on time	25 ms
Typ. switch-off time	45 ms
Temperature resistance	-25 °C cold-resistant
Min. ambient temperature	-25 °C
Max. ambient temperature	50 °C
Min. medium temperature	-25 °C
Max. medium temperature	50 °C

5/2-directional valve, Series CD07, single solenoid

5776085280

CD07

2025-12-08

Medium	Compressed air
Min. oil content of compressed air	0 mg/m ³
Max. oil content of compressed air	1 mg/m ³
Max. particle size	50 µm
Mounting on manifold strip	P-strip PRS strip
Weight	0.57 kg

Material

Housing material	Die cast zinc Polyamide, fiber-glass reinforced
Seal material	Acrylonitrile butadiene rubber
Part No.	5776085280

Technical information

Nominal flow Qn at 6 bar and $\Delta p = 1$ bar

ATEX optional: ATEX version can be produced by combining the basic valve without coil with an ATEX coil. ATEX ID: see ATEX coils catalog page.

Nickel-plated armature guide (only suitable for DC variant), i.e. the base must not be equipped with AC coils.

The min. control pressure must be adhered to, since otherwise faulty switching and valve failure may result!

The pressure dew point must be at least 15 °C less than ambient and medium temperature and may not exceed 3 °C.

The oil content of compressed air must remain constant during the life cycle.

Use only the approved oils from AVENTICS. Further information can be found in the "Technical information" document (available in <https://www.emerson.com/en-us/support>).

5/2-directional valve, Series CD07, single solenoid

5776085280

CD07

2025-12-08

Dimensions in mm

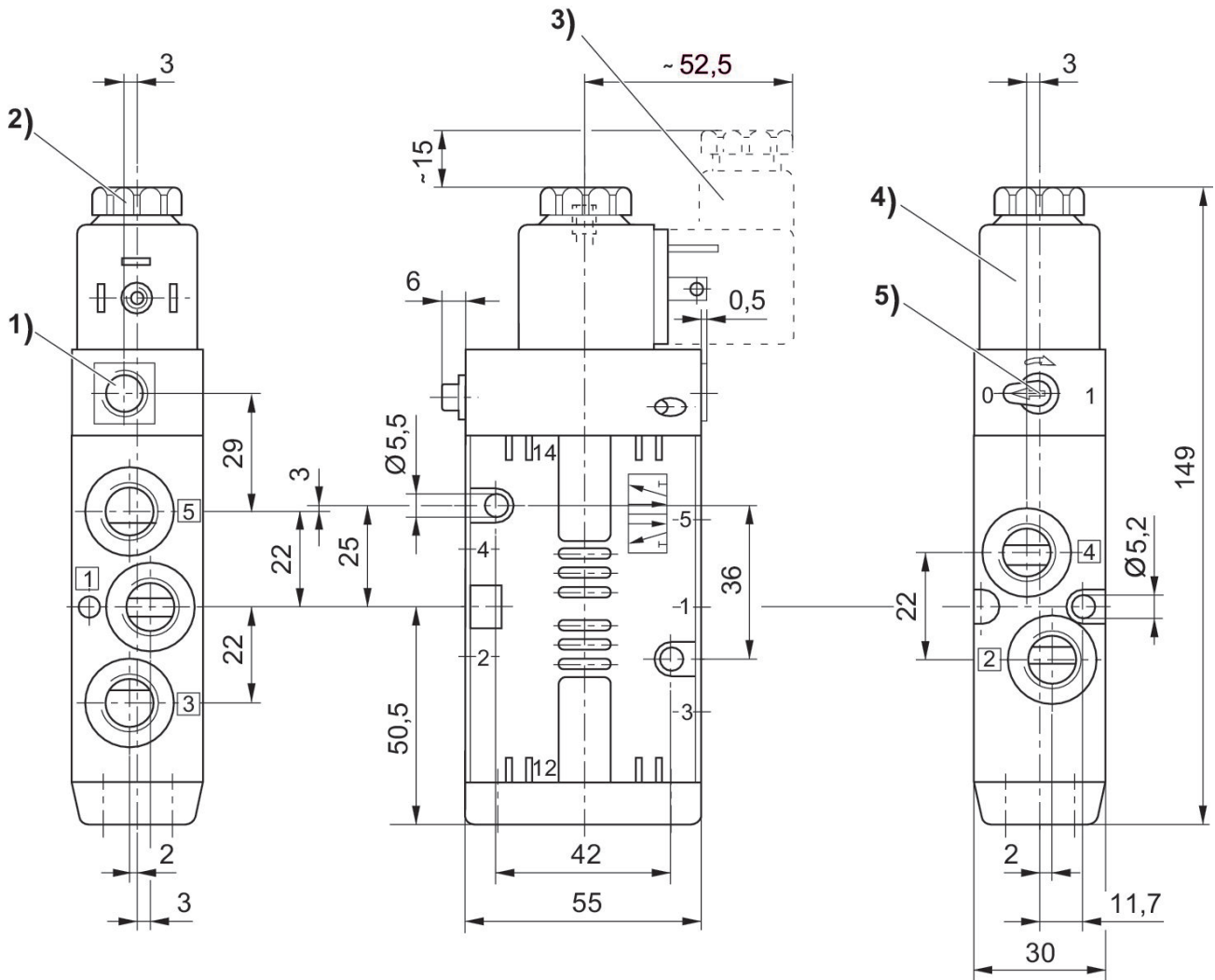

- 1) Only with separate pilot control G 1/8
- 2) After removal of cap M 5 internal thread
- 3) Valve plug connector
- 4) Coil pluggable at 45° intervals
- 5) Manual override