

3/2-directional valve, Series CD07, single solenoid

5772025270

CD07

2025-12-08

AVENTICS Series CD07 Directional valves

The AVENTICS Series CD consists of various spool valves with an extremely durable die-cast zinc housing. Its electrical, pneumatic, or mechanical actuating controls (roller, lever, pedal, or plunger) make the Series CD ideal for applications in harsh environments.

For demanding environments

- Durable design
- Assembly on base plate
- Suitable for extreme ambient temperatures
- ATEX version available

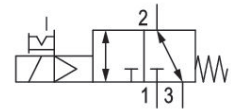

Technical data

Industry	Industrial
Activation	Electrically operated
Frame size	CD07
Valve type	Spool valve, positive overlapping
Switching principle	3/2, with spring return
Valve function	NC/NO
Sealing principle	Soft seal
Connection type	Pipe connection
Manual override	with detent
Compressed air connection	M14x1,5
Compressed air connection type	Internal thread
Pilot control exhaust	with directional pilot air exhaust
Nominal flow Qn	1400 l/min
Nominal flow Qn 1 to 2	1400 l/min
Nominal flow Qn 2 to 3	1400 l/min
Min. working pressure	3 bar
Max. working pressure	10 bar
Min. control pressure	3 bar
Max. control pressure	10 bar

3/2-directional valve, Series CD07, single solenoid

5772025270

CD07

2025-12-08

Electrical connection type	Plug
Electrical connection size	EN 175301-803, form A
Electrical connection number of poles	3-pin
Connector standard	EN 175301-803:2006
Protection class with connection	IP65
Reverse polarity protection	Protected against polarity reversal
Operational voltage	110 V AC
Operational voltage AC at 50 Hz	110 V
Voltage tolerance AC 50 Hz	-20 % / +10 %
Operational voltage AC at 60 Hz	110 V
Voltage tolerance AC 60 Hz	-10 % / +20 %

Pilot	Internal
Coil width	30 mm
Pilot valve width	30 mm
Compatibility index	52
Holding power AC 50 Hz	4.3 VA
Holding power AC 60 Hz	3.3 VA
Switch-on power AC 50 Hz	6.8 VA
Switch-on power AC 60 Hz	5.7 VA

Duty cycle	100 %
Typ. switch-on time	25 ms
Typ. switch-off time	45 ms

Temperature resistance	-25 °C cold-resistant
Min. medium temperature	-25 °C
Max. medium temperature	50 °C
Medium	Compressed air
Min. oil content of compressed air	0 mg/m ³
Max. oil content of compressed air	1 mg/m ³
Max. particle size	50 µm

Weight	0.54 kg
--------	---------

Material

Housing material	Die cast zinc Polyamide, fiber-glass reinforced
------------------	--

3/2-directional valve, Series CD07, single solenoid

5772025270

CD07

2025-12-08

Seal material Acrylonitrile butadiene rubber

Part No. 5772025270

Technical information

Nominal flow Q_n at 6 bar and $\Delta p = 1$ bar

ATEX optional: ATEX version can be produced by combining the basic valve without coil with an ATEX coil. ATEX ID: see ATEX coils catalog page.

option valve: The input and output compressed air connections can be exchanged. The valve can thereby be used in the NC or NO operating mode.

The min. control pressure must be adhered to, since otherwise faulty switching and valve failure may result!

The pressure dew point must be at least 15 °C less than ambient and medium temperature and may not exceed 3 °C.

The oil content of compressed air must remain constant during the life cycle.

Use only the approved oils from AVENTICS. Further information can be found in the "Technical information" document (available in <https://www.emerson.com/en-us/support>).

3/2-directional valve, Series CD07, single solenoid

5772025270

CD07

2025-12-08

Dimensions in mm

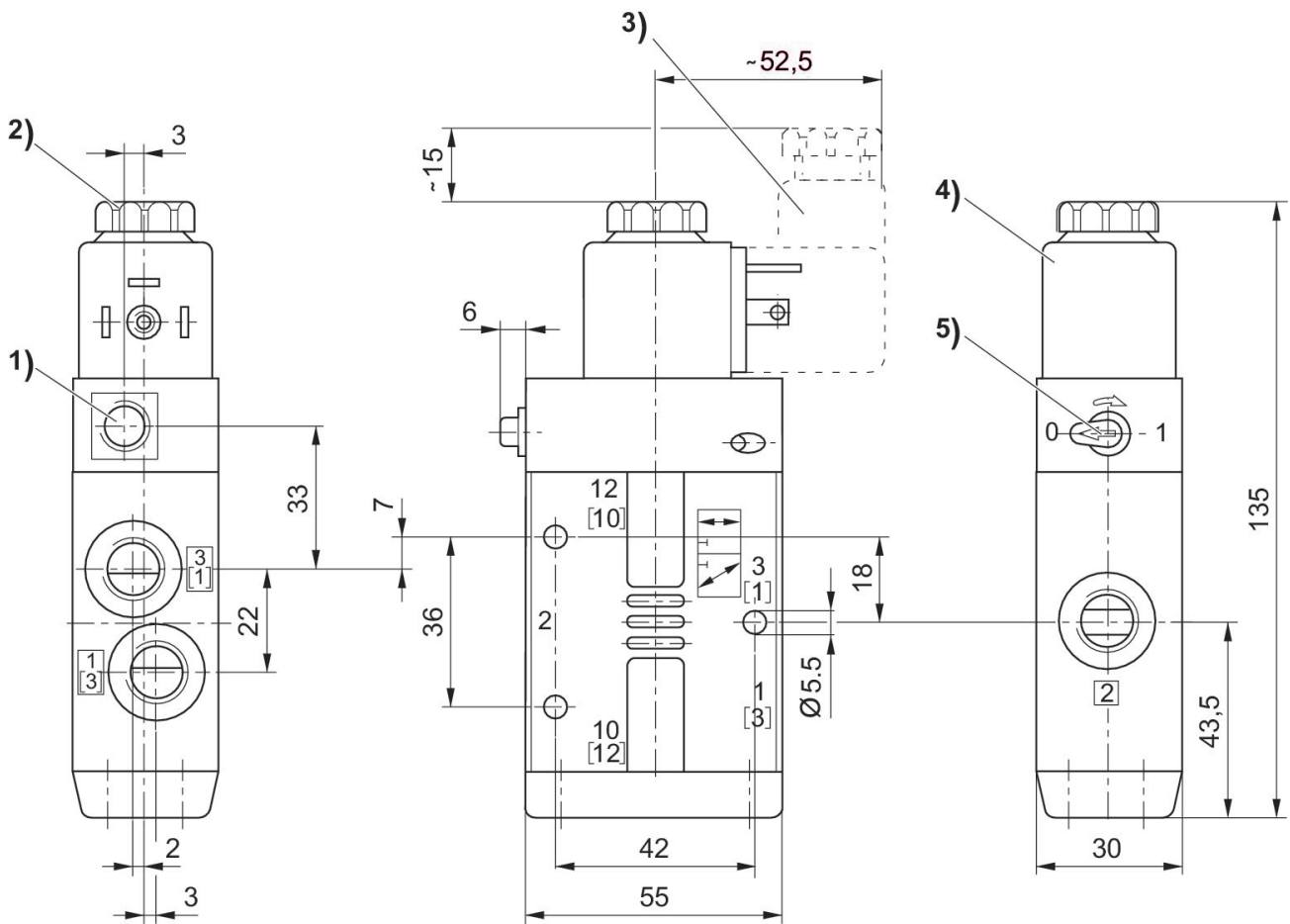

- 1) Only with separate pilot control G 1/8
- 2) After removal of cap M 5 internal thread
- 3) Valve plug connector
- 4) Coil can be plugged at 45° intervals
- 5) Manual override