

## Series 840

The AVENTICS Series 740/840 feature directional valves with soft, abrasion-free diaphragm technology. The simple, reliable and robust design is suitable for all air qualities and ensures high repeatability and unsurpassed service life. Due to its high resilience, the corrosion-resistant polyamide housing is also suited for dusty and damp environments.

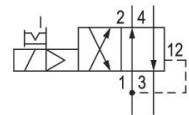

## Technical data

|                                         |                             |
|-----------------------------------------|-----------------------------|
| Industry                                | Industrial                  |
| Activation                              | Electrically                |
| Valve type                              | Diaphragm poppet valve      |
| Switching principle                     | 4/2, with air spring return |
| Actuating control                       | Double Solenoid             |
| Sealing principle                       | Soft seal                   |
| Connection type                         | Pipe connection             |
| Manual override                         | with detent                 |
| Compressed air connection input         | Ø 6x1                       |
| Compressed air connection output        | Ø 6                         |
| Compressed air connection, exhaust      | Ø 6x1                       |
| Compressed air connection pilot exhaust | Ø 4,5                       |
| Nominal flow Qn                         | 200 l/min                   |
| Min. working pressure                   | 1.8 bar                     |
| Max. working pressure                   | 10 bar                      |

# 4/2-directional valve, Series 840

Series 840

5728455680

2025-07-21

|                                    |                                                                                                                                                                                                                                          |
|------------------------------------|------------------------------------------------------------------------------------------------------------------------------------------------------------------------------------------------------------------------------------------|
| Note                               | The maximum operating pressure depends on the ambient temperature. The following values are applicable: -15 °C ... 50 °C: Operating pressure 1,8 bar... 8 bar possible. -15 °C ... 40 °C: Operating pressure 1,8 bar... 10 bar possible. |
| Min. control pressure              | 1.5 bar                                                                                                                                                                                                                                  |
| Max. control pressure              | 10 bar                                                                                                                                                                                                                                   |
| Electrical connection type         | Plug                                                                                                                                                                                                                                     |
| Electrical connection size         | EN 175301-803, form C                                                                                                                                                                                                                    |
| Connector standard                 | EN 175301-803, form C                                                                                                                                                                                                                    |
| Protection class with connection   | IP65                                                                                                                                                                                                                                     |
| Reverse polarity protection        | Protected against polarity reversal                                                                                                                                                                                                      |
| Operational voltage                | 230 V AC                                                                                                                                                                                                                                 |
| Operational voltage AC at 50 Hz    | 230 V                                                                                                                                                                                                                                    |
| Voltage tolerance AC 50 Hz         | -10 % / +15 %                                                                                                                                                                                                                            |
| Operational voltage AC at 60 Hz    | 230 V                                                                                                                                                                                                                                    |
| Voltage tolerance AC 60 Hz         | -10 % / +15 %                                                                                                                                                                                                                            |
| Pilot                              | Internal                                                                                                                                                                                                                                 |
| Coil width                         | 20 mm                                                                                                                                                                                                                                    |
| Pilot valve width                  | 22.5 mm                                                                                                                                                                                                                                  |
| LED status display                 | Red                                                                                                                                                                                                                                      |
| Holding power AC 50 Hz             | 2.5 VA                                                                                                                                                                                                                                   |
| Holding power AC 60 Hz             | 2.2 VA                                                                                                                                                                                                                                   |
| Switch-on power AC 50 Hz           | 3.5 VA                                                                                                                                                                                                                                   |
| Switch-on power AC 60 Hz           | 3 VA                                                                                                                                                                                                                                     |
| Duty cycle                         | 100 %                                                                                                                                                                                                                                    |
| Typ. switch-on time                | 12 ms                                                                                                                                                                                                                                    |
| Typ. switch-off time               | 12 ms                                                                                                                                                                                                                                    |
| Min. ambient temperature           | -15 °C                                                                                                                                                                                                                                   |
| Max. ambient temperature           | 50 °C                                                                                                                                                                                                                                    |
| Min. medium temperature            | -15 °C                                                                                                                                                                                                                                   |
| Max. medium temperature            | 50 °C                                                                                                                                                                                                                                    |
| Medium                             | Compressed air                                                                                                                                                                                                                           |
| Min. oil content of compressed air | 0 mg/m <sup>3</sup>                                                                                                                                                                                                                      |
| Max. oil content of compressed air | 1 mg/m <sup>3</sup>                                                                                                                                                                                                                      |
| Max. particle size                 | 50 µm                                                                                                                                                                                                                                    |

Mounting on manifold strip

PRS strip

Weight

0.102 kg

## Material

Housing material

Polyoxymethylene

Seal material

Acrylonitrile butadiene rubber

Part No.

5728455680

## Technical information

Versions with voltage of less than 50 V DC do not have a protective ground.

The min. control pressure must be adhered to, since otherwise faulty switching and valve failure may result!

The pressure dew point must be at least 15 °C less than ambient and medium temperature and may not exceed 3 °C.

The oil content of compressed air must remain constant during the life cycle.

Use only the approved oils from AVENTICS. Further information can be found in the "Technical information" document (available in <https://www.emerson.com/en-us/support>).

## Dimensions

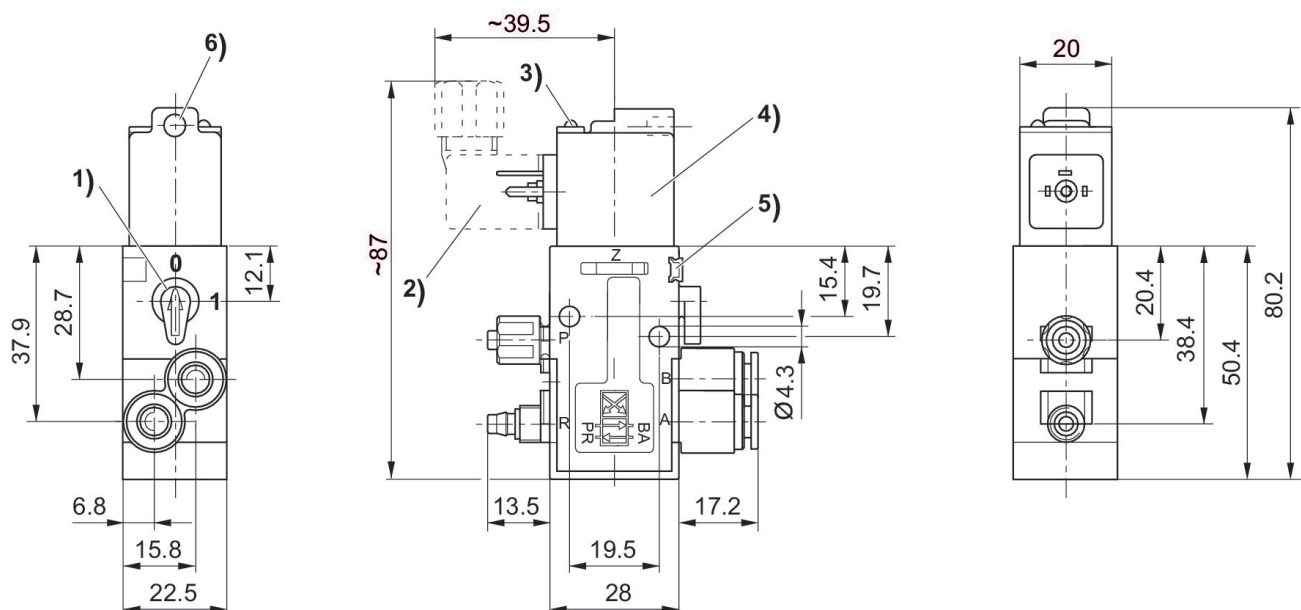

1) Manual override 2) Valve plug connector 3) LED display 4) Coil can be rotated at 180° intervals  
5) Mounting space for name plate 6) Hole for M5 fitting or silencer Ø 4.5 mm