

AVENTICS Series CD07 Directional valves

Qn = 900 ... 1400 l/min

- Durable design
- Assembly on base plate
- Suitable for extreme ambient temperatures
- ATEX version available

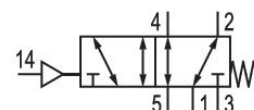

Technical data

Industry	Industrial
Activation	Pneumatically operated
Frame size	CD07
Valve type	Spool valve, positive overlapping
Switching principle	5/2, with spring return
Sealing principle	Soft seal
Connection type	Pipe connection
Compressed air connection	M14x1,5
Compressed air connection input	M14x1,5
Compressed air connection output	M14x1,5
Compressed air connection, exhaust	M14x1,5
Compressed air connection pilot exhaust	M10x1
Nominal flow Qn	1200 l/min
Min. working pressure	-0.95 bar
Max. working pressure	10 bar
Min. control pressure	3 bar

Temperature resistance	-25 °C cold-resistant
Certificates	Suitable for ATEX
ATEX	Suitable for ATEX
Min. ambient temperature	-25 °C
Max. ambient temperature	80 °C
Min. medium temperature	-25 °C
Max. medium temperature	80 °C
Medium	Compressed air
Min. oil content of compressed air	0 mg/m ³
Max. oil content of compressed air	1 mg/m ³
Max. particle size	50 µm
Mounting on manifold strip	P-strip PRS strip
Weight	0.5 kg

Material

Housing material	Die cast zinc
Seal material	Acrylonitrile butadiene rubber
Part No.	5710509300

Technical information

Nominal flow Q_n at 6 bar and $\Delta p = 1$ bar

The min. control pressure must be adhered to, since otherwise faulty switching and valve failure may result!

The pressure dew point must be at least 15 °C less than ambient and medium temperature and may not exceed 3 °C.

The oil content of compressed air must remain constant during the life cycle.

Use only the approved oils from AVENTICS. Further information can be found in the "Technical information" document (available in <https://www.emerson.com/en-us/support>).

5/2-directional valve, Series CD07

5710509300

CD07

2026-01-07

Dimensions in mm

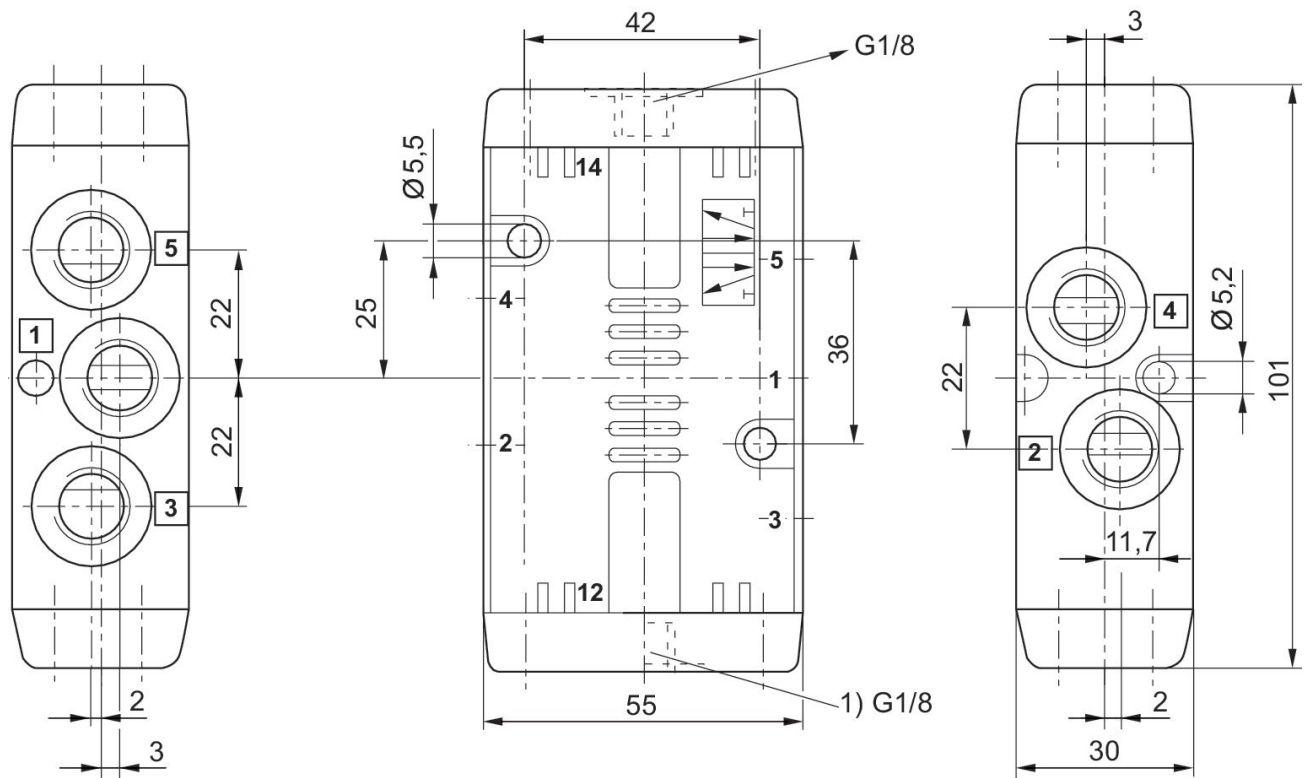

1) Part No.: 5710501100
5710509300: Protected against dust