

# 5/2-directional valve, Series CD07

5710500100

AVENTICS Series CD07 Directional valves

- $Q_n = 900 \dots 1400$  l/min

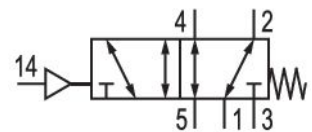

## Technical data

Industry	Industrial
Activation	Pneumatically
Frame size	CD07
Valve type	Spool valve, positive overlapping
Switching principle	5/2, with spring return
Sealing principle	soft seal
Connection type	Pipe connection
Compressed air connection	G 1/4
Standard compressed air connection	according to ISO 228-1
Compressed air connection input	G 1/4
Compressed air connection output	G 1/4
Compressed air connection, exhaust	G 1/4
Compressed air connection pilot input	G 1/8

Nominal flow Qn	1200 l/min
Working pressure min.	-0.95 bar
Working pressure max	10 bar
Control pressure min.	3 bar
Control pressure max.	10 bar
Certificates	Suitable for ATEX
ATEX	Suitable for ATEX
Min. ambient temperature	-25 °C
Max. ambient temperature	80 °C
Min. medium temperature	-25 °C
Max. medium temperature	80 °C
Medium	Compressed air
Oil content of compressed air min.	0 mg/m <sup>3</sup>
Oil content of compressed air max.	1 mg/m <sup>3</sup>
Max. particle size	50 µm
Mounting on manifold strip	P-strip PRS strip
Weight	0.5 kg

## Material

Housing material	Die cast zinc
Seal material	Acrylonitrile butadiene rubber
Part No.	5710500100

## Technical information

The min. control pressure must be adhered to, since otherwise faulty switching and valve failure may result!

The pressure dew point must be at least 15 °C less than ambient and medium temperature and may not exceed 3 °C.

The oil content of compressed air must remain constant during the life cycle.

Use only the approved oils from AVENTICS. Further information can be found in the "Technical information" document (available in <https://www.emerson.com/en-us/support>).

## Dimensions

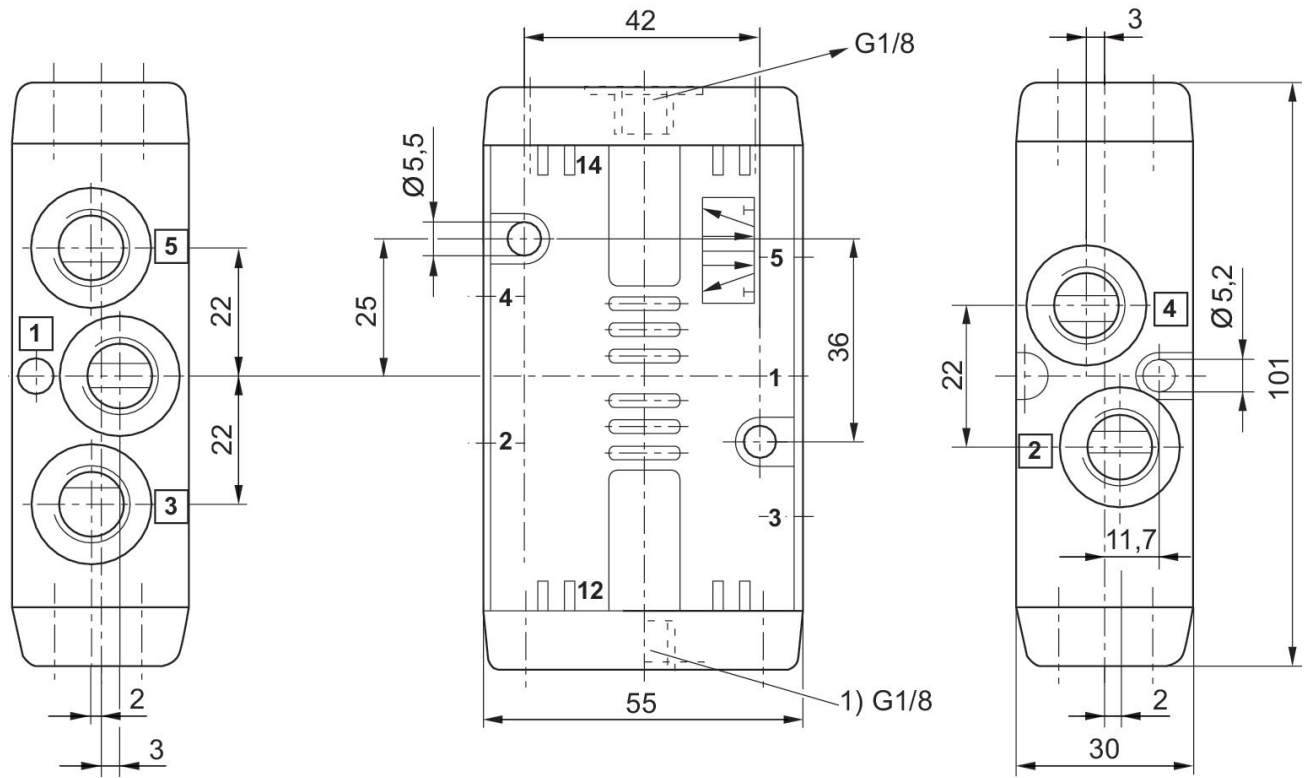

1) Part No.: 5710501100  
5710509300: Protected against dust