

AVENTICS Series LU6 Locking units

The AVENTICS Series LU6 is a mechanical locking unit/brake for piston rods in pneumatic cylinders according to ISO 15552 or comparable round bars. It is a safety component in accordance with the Machinery Directive 2006/42/EC (CE mark) and can be used in safety-relevant controls.



Technical data

Industry	Industrial
Function	Static holding Dynamic braking
Function	Holding and braking: non-adjustable spring Release: compressed air
Type	Clamping jaw lock
Piston Ø	40 mm
Piston diameter	40 mm
suitable piston rod Ø	16 mm
Piston rod extension	125 mm
Compressed air connection	G 1/8
Max. piston speed v max.	1 m/s
Min. release pressure	4 bar
Max. release pressure	10 bar
Min. medium temperature	-25 °C
Max. medium temperature	80 °C
Medium	Compressed air
Max. particle size	5 µm
Min. ambient temperature	-25 °C
Max. ambient temperature	80 °C

Locking unit, Series LU6

5231996402

Locking
units

2023-11-07

Min. oil content of compressed air	0 mg/m ³
Required flow rate Qn	70 l/min
Braking energy per braking cycle related to B10d, EB10d	3 J
Max. braking energy per braking cycle ELU6	9 J
Max. braking energy per hour PLU6	1350 J
Max. total braking energy E _{total}	6 MJ
Max. moving mass m _{max} , external	122 kg
Max. torsional moment of piston rod	1 Nm
B10d value static	5.000.000
B10d value dynamic	2.000.000
Buckling protection of the piston rod 1), max. cylinder stroke for Euler case 1	1100 mm
Buckling protection of the piston rod 1), max. cylinder stroke for Euler case 2	550 mm
Max. holding/braking force FLU6	1200 N
Brake response time t _{brake} (4 bar)	0.08 s
Brake response time t _{brake} (6.3 bar)	0.1 s
Brake response time t _{brake} (10 bar)	0.12 s
Weight	1 kg

Material

Housing	Aluminum
Surface housing	anodized
Scraper	Nitrile butadiene rubber
Seals	Nitrile butadiene rubber
Part No.	5231996402

Technical information

The maximum ambient and medium temperature is +70°C for the dynamic braking function.

Note: Before pressurizing the locking unit, make sure that there is a balance of forces at the piston on the drive cylinder. Please see the operating instructions for further safety-relevant information.

The locking unit can be used in controls with a max. performance level e in accordance with DIN EN ISO 13849-1 ("basic and well-tried safety principles"). For applications in category 2 to 4 controls, additional control measures according to DIN EN ISO 13849-1 are required.

The locking unit can be used as an individual component or pre-mounted on a cylinder..

Scope of delivery: LU6, each with 4 flange nuts, washers, and tie rods

Only applies in dynamic cases, and only retracting

The values for the max. braking energy per braking cycle are equivalent to the cushioning energy for cylinder series PRA and TRB.

Locking unit, Series LU6

5231996402

Locking units

2023-11-07

Dimensions

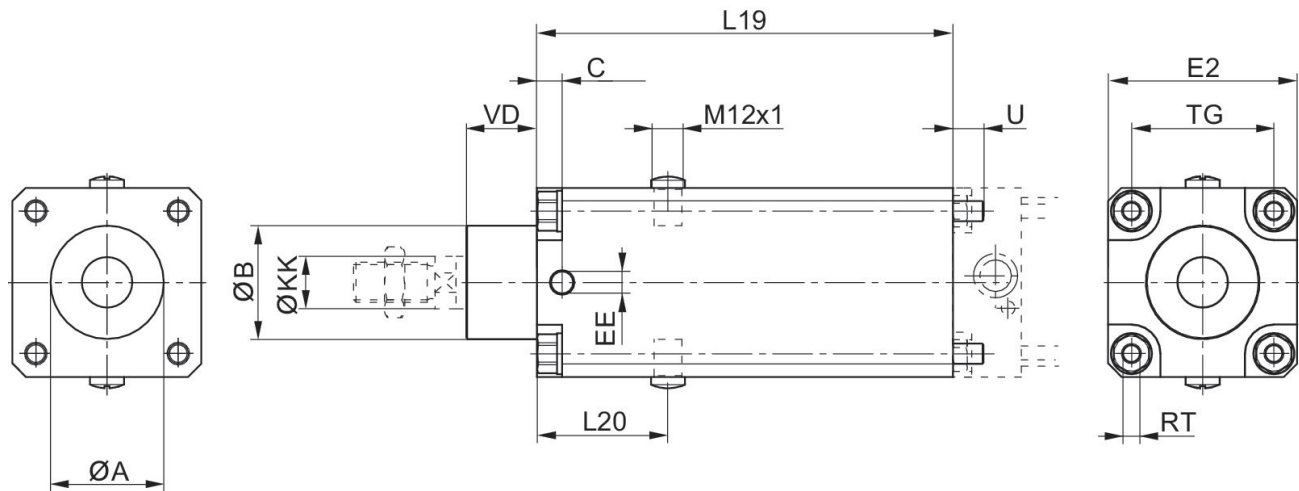

Piston Ø	Part No.	ØA	ØB d11	C	EE	E2	L19	L20	ØKK e8-h9
32	5230996402	30,5	30	9	G1/8	48	125	44	12
40	5231996402	35,5	35	9	G1/8	53	125	44	16
50	5232996402	40,5	40	9	G1/8	63	145	49	20
63	5233996402	45,5	45	10	G1/8	75	165	52	20
80	5234996402	45,5	45	11	G1/8	98	185	61.5	25
100	5235996402	55,5	55	13	G1/8	118	220	68	25
125	5236996402	60,5	60	13	G1/4	142	220	75	32

Piston Ø	TG	RT	U	VD
32	32,5	M6	10	19
40	38	M6	10	21
50	46,5	M8	11	28
63	56,5	M8	11	28
80	72	M10	16	34
100	89	M10	16	37
125	110	M12	16	45

Locking unit, Series LU6

5231996402

Locking units

2023-11-07

Circuit example for safety-related stop functions:

horizontal installation position

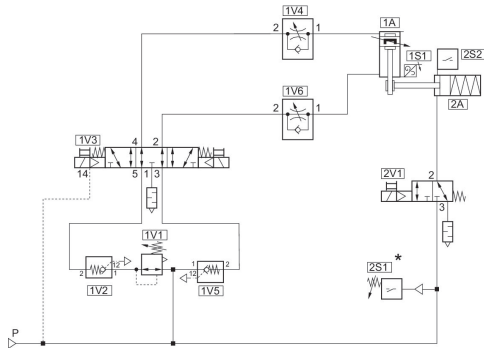

Channel 1: Safe stopping and closing

Channel 2: Safe brake control

* From [[4] bar]: release of 2V1

Circuit example for non-safety relevant functions:

Vertical mounting orientation

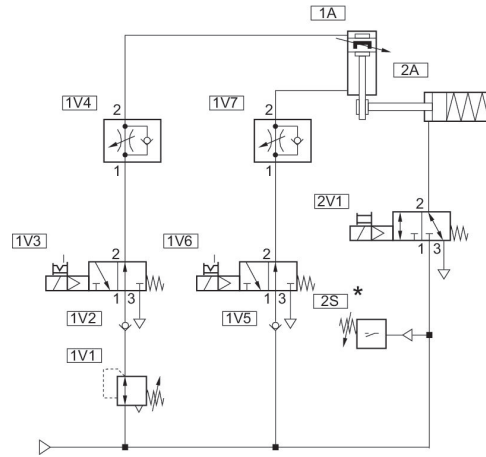

* From [[4] bar]: release of 2V1

Circuit example for non-safety relevant functions:

horizontal installation position

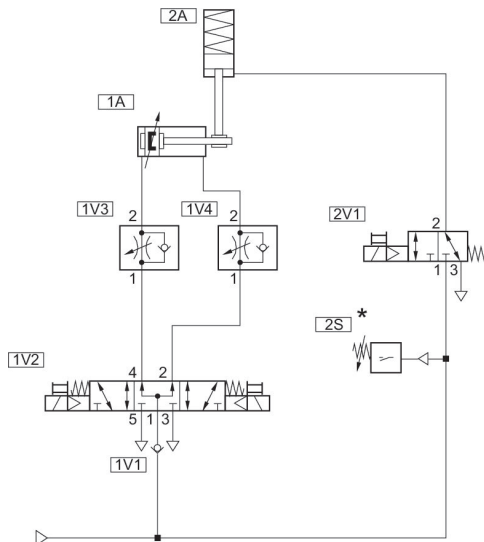

* From [[4] bar]: release of 2V1

Circuit example for safety-related stop functions:

Vertical mounting orientation

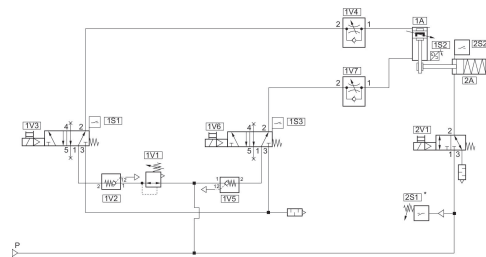

Channel 1: Safe stopping and closing

Channel 2: Safe brake control

* From [[4] bar]: release of 2V1