

3/2-directional valve, Series DP22, Basic valve without coil, Pipe connection, KR, NO

3124A3F13C9N4G8

Series
DP22

2024-09-30

- Coil width 22 mm
- Plate connection

Series DP22

The AVENTICS Series DP offer a simple, reliable and robust solution for all classical pilot control functions with direct electrical operation.

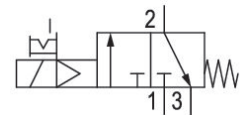

Technical data

Industry	Industrial
Activation	Electrically
Valve type	Poppet valve
Switching principle	3/2, with spring return
Valve function	NC
Actuating control	Double Solenoid
Sealing principle	Soft seal
Manual override	with detent
Compressed air connection input	Plate connection
Compressed air connection output	Plate connection
Compressed air connection, exhaust	M5
Nominal flow Q _n 1 to 2	65 l/min
Nominal flow Q _n 2 to 3	85 l/min
Min. working pressure	0 bar
Max. working pressure	7 bar

3/2-directional valve, Series DP22, Basic valve without coil, Pipe connection, KR, NO

3124A3F13C9N4G8

Series
DP22

2024-09-30

Electrical connection type	Plug
Electrical connection size	Form B
Electrical connection number of poles	3-pin
Protection class with connection	IP65
Coil insulation class	Class F
Operational voltage	24 V DC / 48 V AC
Operational voltage DC	24 V
Voltage tolerance DC	-10 % / +10 %
Operational voltage AC at 50 Hz	48 V
Voltage tolerance AC 50 Hz	-10 % / +10 %
Operational voltage AC at 60 Hz	48 V
Voltage tolerance AC 60 Hz	-10 % / +10 %
Coil width	22 mm
Pilot valve width	22 mm
Compatibility index	44
Power consumption DC	4.8 W
Max. current consumption	230 mA
Holding power AC 50 Hz	7 VA
Holding power AC 60 Hz	6 VA
Switch-on power AC 50 Hz	11 VA
Switch-on power AC 60 Hz	9.4 VA
Duty cycle	100 %
Typ. switch-on time	8.7 ms
Typ. switch-off time	6 ms
Blocking principle	Single valve
Min. ambient temperature	-25 °C
Max. ambient temperature	60 °C
Min. medium temperature	-25 °C
Max. medium temperature	60 °C
Medium	Compressed air
Min. oil content of compressed air	0 mg/m ³
Max. oil content of compressed air	5 mg/m ³
Max. particle size	5 µm
Mounting screws	M3
Weight	0.09 kg

3/2-directional valve, Series DP22, Basic valve without coil, Pipe connection, KR, NO

3124A3F13C9N4G8

Series
DP22

2024-09-30

Material

Housing material	Polyamide fiber-glass reinforced
Material Coil	Polyamide
Seal material	Ethylene acrylate copolymers

Part No. 3124A3F13C9N4G8

Technical information

The min. control pressure must be adhered to, since otherwise faulty switching and valve failure may result!

The pressure dew point must be at least 15 °C less than ambient and medium temperature and may not exceed 3 °C.

The oil content of compressed air must remain constant during the life cycle.

Use only the approved oils from AVENTICS. Further information can be found in the "Technical information" document (available in <https://www.emerson.com/en-us/support>).

3/2-directional valve, Series DP22, Basic valve without coil, Pipe connection, KR, NO

Series
DP22

2024-09-30

3124A3F13C9N4G8
Dimensions

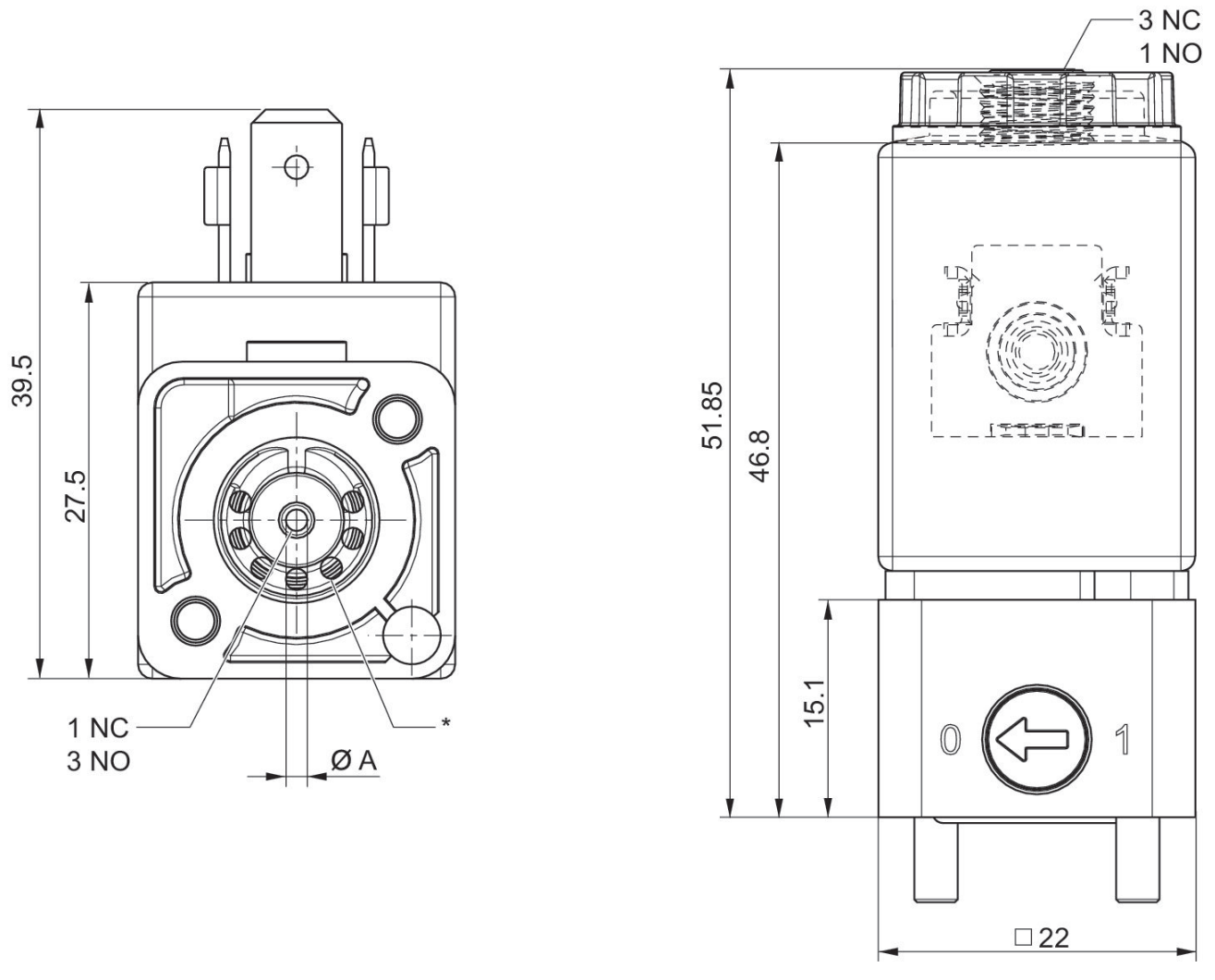

* Port 2 (Output)