

柔性耦合连接件

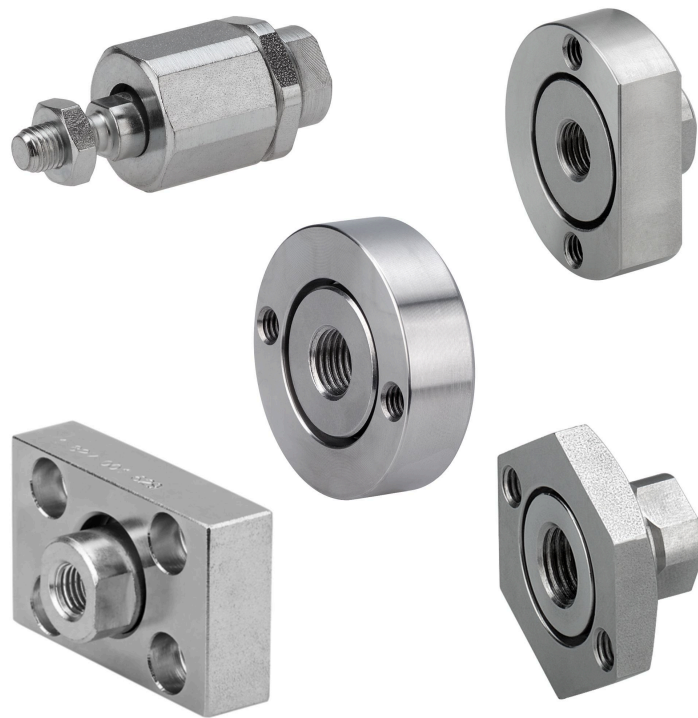

AVENTICS™

AVENTICS 挠性联轴器



柔性耦合连接件

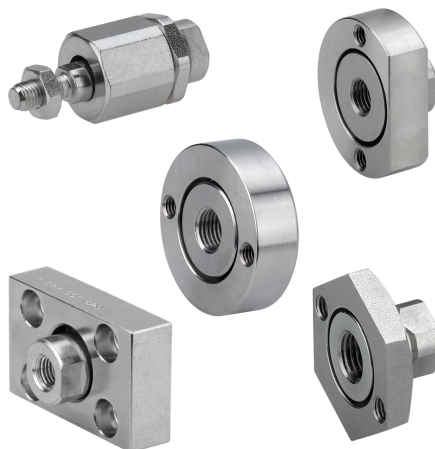

柔性耦合连接件 PM5 , CM2 系列



适合的活塞杆螺纹	用于系列	材料	物料号
M4	MNI	钢, 镀铬	1826409008
M5		钢, 镀铬	R412007860
M6x1	CCL-IC, CCI, MNI	钢, 镀铬	R412026140
M8x1,25	CCL-IC, CCI, MNI	钢, 镀铬	R412026141
M10x1,25	PRA/TRB, CCL-IC/-IS, CCI, SSI, KPZ, 167, CVI, RPC	钢, 镀铬	R412026142
M12x1,25	PRA/TRB, CCL-IC/-IS, CCI, SSI, KPZ, 167, CVI, RPC	钢, 镀铬	R412026143
M16x1,5	PRA/TRB, CCL-IC/-IS, CCI, KPZ, 167, CVI, RPC, RDC	钢, 镀铬	R412026144
M20x1,5	PRA/TRB, CCL-IS, SSI, KPZ, 167, CVI	钢, 镀铬	R412026145
M27x2	PRA/TRB, CCL-IS, CVI	钢, 镀铬	1826409006
M36x2	ITS	钢, 镀铬	1826409007
M42x2	ITS	钢, 镀铬	R412007729

规格

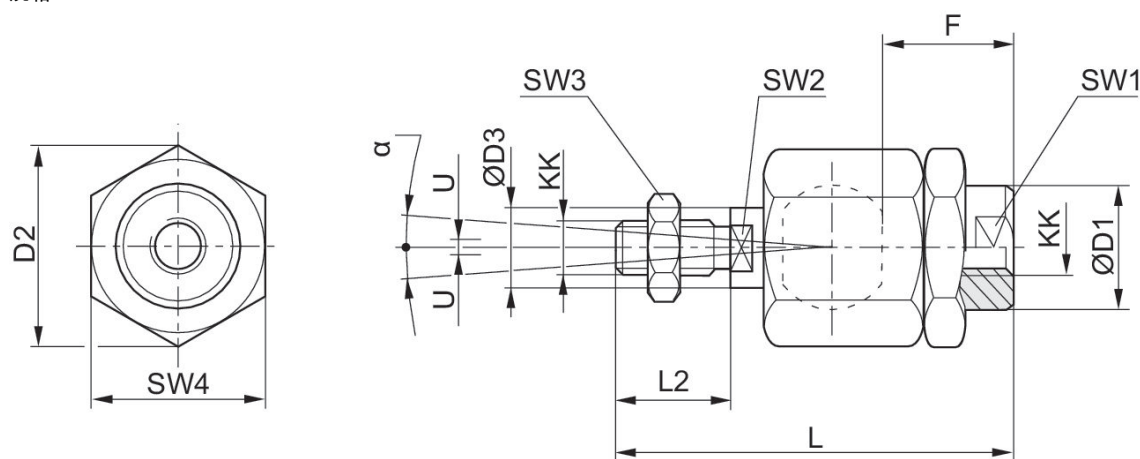

* 的径向平衡

物料号	KK	Ø D1	D2	Ø D3	F	L ±2	L2	SW1	SW2	SW3
1826409008	M4	12	13.5	4	13	33	8	12	3.2	7
R412007860	M5	8.5	14.8	6	12	38.5	13.5	7	5	8

物料号	KK	Ø D1	D2	Ø D3	F	L ±2	L2	SW1	SW2	SW3
R412026140	M6x1	8.5	14.5	6	11	36.5	11	7	5	10
R412026141	M8x1.25	12.5	19	8	21	58	21	11	7	13
R412026142	M10x1.25	22	32	14	23	74.5	23	19	12	17
R412026143	M12x1.25	22	32	14	24	75	24	19	12	19
R412026144	M16x1.5	32	45	22	30	103	30	30	20	24
R412026145	M20x1.5	32	45	22	40	119	40	30	20	30
1826409006	M27x2	62	62	28	48	147	54	32	24	41
1826409007	M36x2	80	80	38	86	241	72	50	32	55
R412007729	M42x2	64	98	42	96	271	82	60	36	65

物料号	SW4	U	α [°]	1)
1826409008	11	0,5	8	0.05-0.2
R412007860	13	0,5	8	0.05-0.2
R412026140	13	0,7	6	0.05-0.5
R412026141	17	0,7	8	0.05-0.5
R412026142	30	1	8	0.05-0.5
R412026143	30	1	7	0.05-0.5
R412026144	41	1	6	0.05-0.5
R412026145	41	1	6	0.05-0.5
1826409006	55	1	8	0.05-0.2
1826409007	75	1	8	0.05-0.2
R412007729	85	1	8	0.05-0.2

1) 轴向间隙

柔性耦合连接件 PM7 , CM2 系列



适合的活塞杆螺纹	用于系列	材料	物料号
M10x1,25	PRA/TRB, CCL-IC/-IS, CCI, SSI, KPZ, 167, RPC	钢, 镀铬	1827001629
M12x1,25	PRA/TRB, CCL-IC/-IS, CCI, SSI, KPZ, 167, RPC	钢, 镀铬	1827001630
M16x1,5	PRA/TRB, CCL-IC/-IS, CCI, SSI, KPZ, 167, RPC	钢, 镀铬	1827001631
M20x1,5	PRA/TRB, CCL-IS, SSI, KPZ, CVI, 167	钢, 镀铬	1827001632
M27x2	PRA/TRB, CCL-IS, CVI	钢, 镀铬	1827001633
M36x2	ITS	钢, 镀铬	1827001634

规格

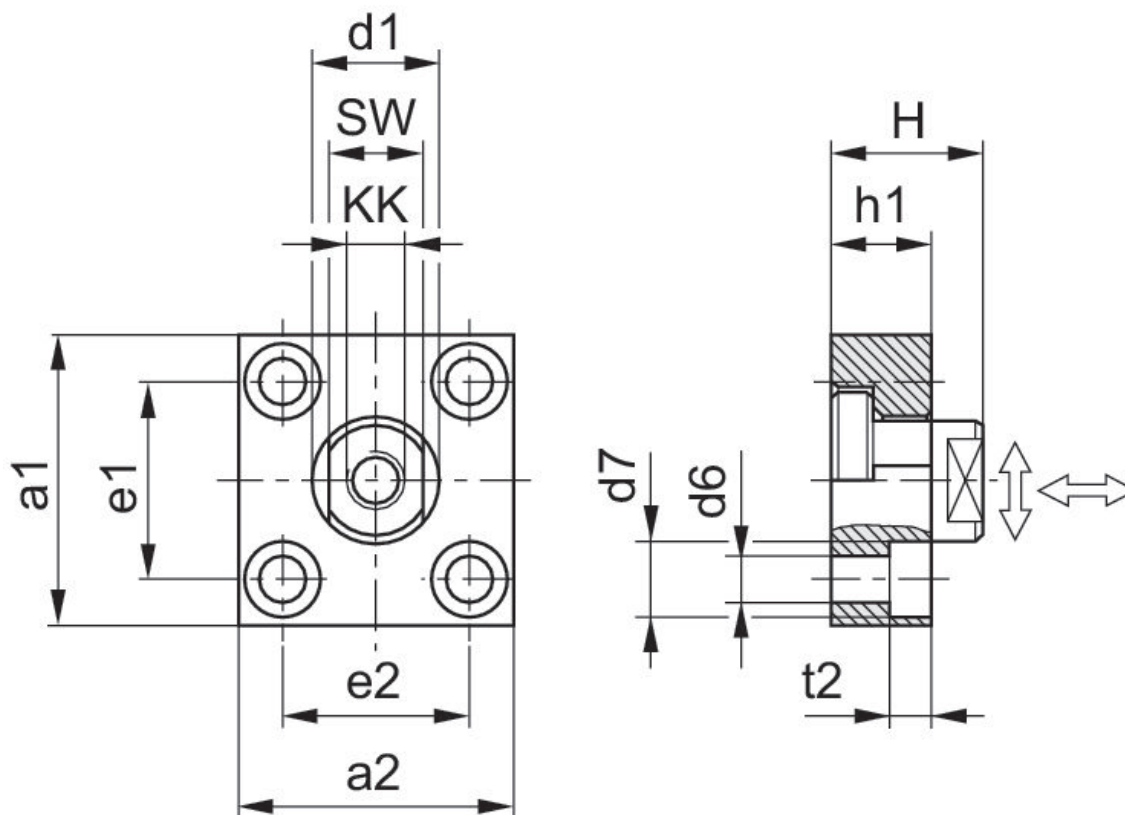

KK	物料号	a1	a2	d1 h11	d6 H13	d7 H13	e1 H13	e2	h1	t2
M10x1.25	1827001629	60	37	20	6.6	11	36 ±0,15	23 ±0,15	15	7
M12x1.25	1827001630	60	56	25	9	15	42 ±0,2	38 ±0,2	20	9
M16x1.5	1827001631	80	80	30	11	18	58 ±0,2	58 ±0,2	20	11
M20x1.5	1827001632	90	90	40	14	20	65 ±0,3	65 ±0,3	20	13
M27x2	1827001633	90	90	40	14	20	65 ±0,3	65 ±0,3	20	13
M36x2	1827001634	125	125	60	18	26	90 ±0,3	90 ±0,3	30	17

KK	H	SW	连接销的拧紧 力矩最大 ± 5%	轴向间隙 最小/最大	径向间隙 最小/最大
M10x1.25	24	17	17 Nm	0,4 - 0,8 mm	1,9 - 2,3 mm
M12x1.25	30	19	29 Nm	0,4 - 0,8 mm	1,9 - 2,3 mm
M16x1.5	32	24	71 Nm	0,4 - 0,8 mm	1,9 - 2,3 mm
M20x1.5	35	36	138 Nm	0,4 - 0,8 mm	1,9 - 2,3 mm
M27x2	35	36	350 Nm	0,4 - 20,31 mm	1,9 - 2,3 mm
M36x2	55	50	1080 Nm	0,4 - 0,95 mm	2,8 - 3,4 mm

柔性耦合连接件 GU3 A 形，CG1 系列



适合的活塞杆螺纹	材料	物料号
M8	不锈钢	R413000277
M10x1,25	不锈钢	R413000278

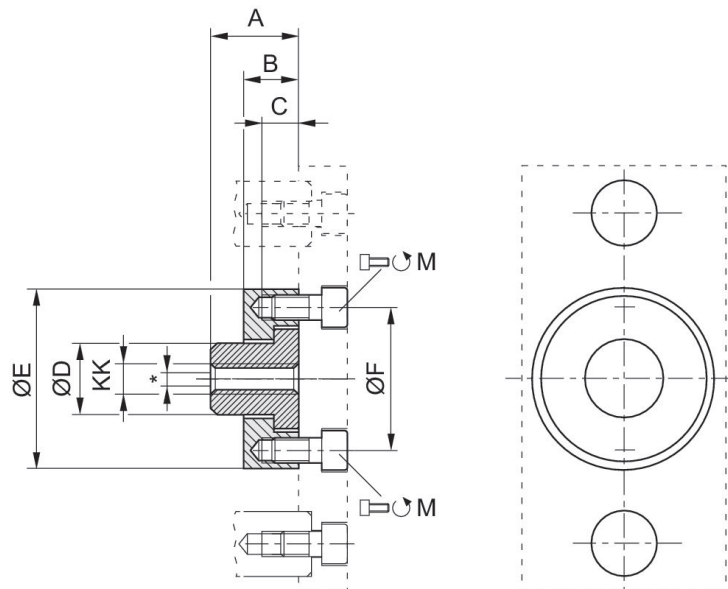

KK	物料号	Ø	M	A	B	C	ØD	ØE	ØF
M10x1,25	R413000279	32	2x M6x12	22	14	8	18	45	36
M20x1,5	R413000282	80/100	4x M6x14	32	14	9.5	30	60	51

柔性耦合连接件 GU3 A 形，CG1 系列



适合的活塞杆螺纹	材料	物料号
M10x1,25	不锈钢	R413000279
M20x1,5	不锈钢	R413000282

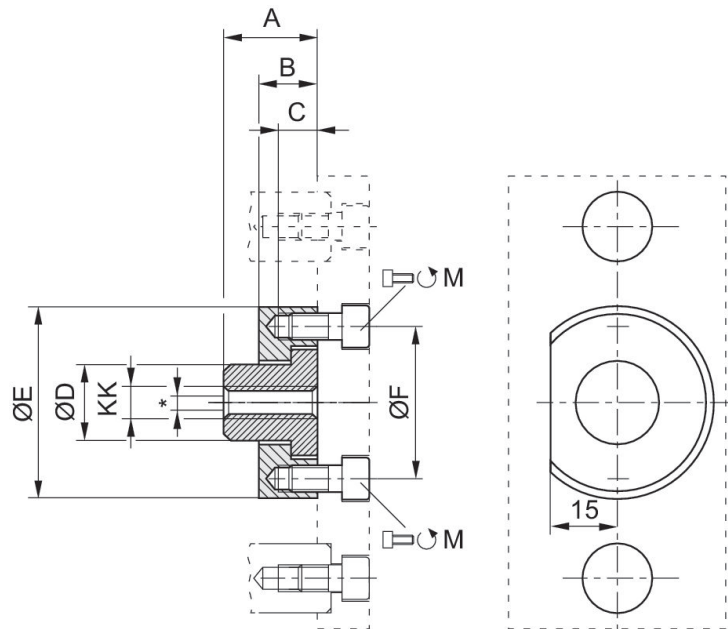

* 1.0 ... 2.5 mm的径向平衡

KK	物料号	Ø	M	A	B	C	ØD	ØE	ØF
M8	R413000277	20	2x M6x12	22	14	8	18	45	36
M10x1,25	R413000278	25	2x M6x12	22	14	8	18	45	36

柔性耦合连接件 GU3 B 形，CG1 系列



适合的活塞杆螺纹	材料	物料号
M8	不锈钢	R413000283
M10x1,25	不锈钢	R413000284
M20x1,5	不锈钢	R413000285

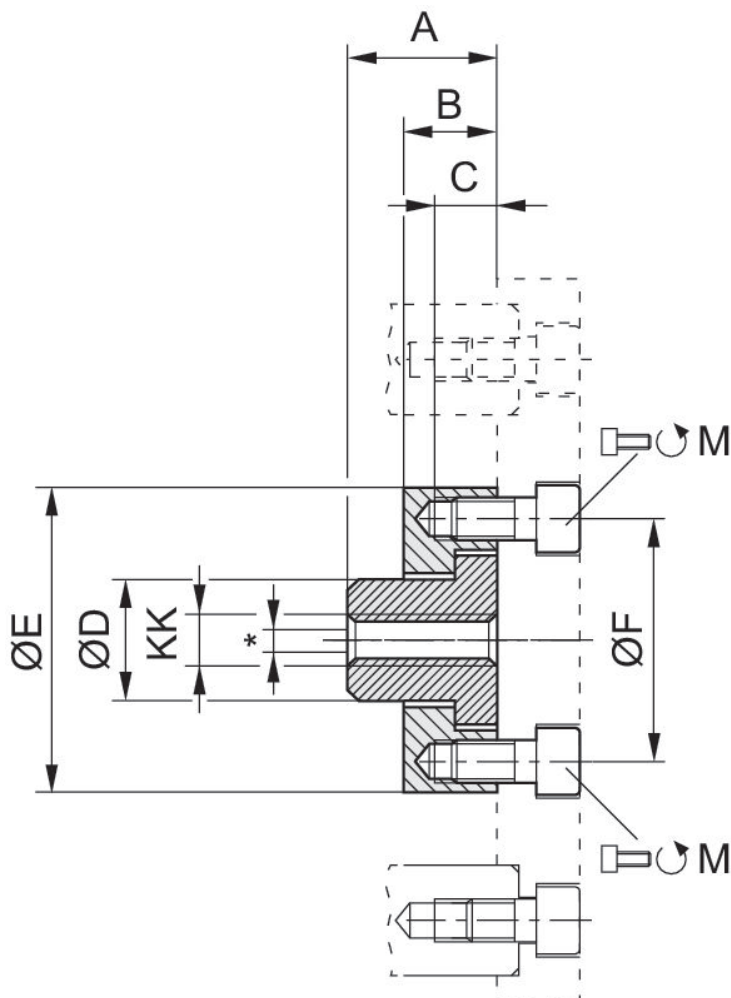

* 1.5 ... 1.8 mm的径向平衡

KK	物料号	Ø	M	A	B	C	D	ØE	ØF
M8	R413000283	20	2x M5x12	22	6	6	14.5	SW 30	26
M10x1,25	R413000284	25/32	2x M5x12	17	6	6	14.5	SW 30	26
M20x1,5	R413000285	80/100	4x M6x20	32	14	9.5	30	60	51

柔性耦合连接件 GU3 C 形，CG1 系列



适合的活塞杆螺纹	材料	物料号
M6	不锈钢	R413000276
M12x1,25	不锈钢	R413000280
M16x1,5	不锈钢	R413000281

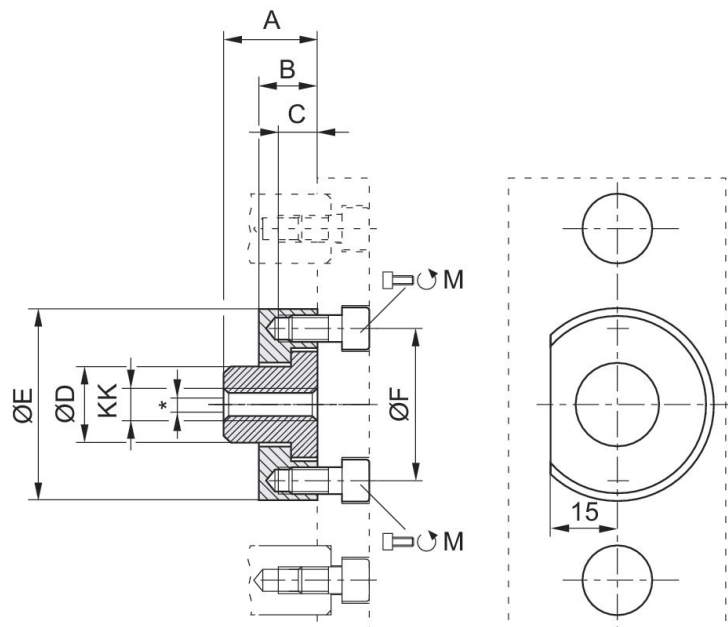

* 1.0 ... 2.5 mm的径向平衡

KK	物料号	Ø	M	A	B	C	D	ØE	ØF
M6	R413000276	12/16	2x M4x10	18	7	7	10	22	15
M12x1,25	R413000280	40	2x M6x12	22	14	8	18	45	36
M16x1,5	R413000281	50/63	4x M6x14	26	14	8	24	54	45

Efficient pneumatic solutions, our program: cylinders and drives, valves and valve systems, air supply management



Visit us: [Emerson.com/Aventics](https://www.emerson.com/Aventics)

Your local contact: [Emerson.com/contactus](https://www.emerson.com/contactus)



[Emerson.com](https://www.emerson.com)



[Facebook.com/EmersonAutomationSolutions](https://www.facebook.com/EmersonAutomationSolutions)



[LinkedIn.com/company/Emerson-Automation-Solutions](https://www.linkedin.com/company/Emerson-Automation-Solutions)



[Twitter.com/EMR_Automation](https://twitter.com/EMR_Automation)

An example configuration is depicted on the title page. The delivered product may thus vary from that in the illustration. Subject to change. This Document, as well as the data, specifications and other information set forth in it, are the exclusive property of AVENTICS GmbH. It may not be reproduced or given to third parties without its consent. Only use the AVENTICS products shown in industrial applications. Read the product documentation completely and carefully before using the product. Observe the applicable regulations and laws of the respective country. When integrating the product into applications, note the system manufacturer's specifications for safe use of the product. The data specified only serve to describe the product. No statements concerning a certain condition or suitability for a certain application can be derived from our information. The information given does not release the user from the obligation of own judgment and verification. It must be remembered that the products are subject to a natural process of wear and aging.

The Emerson logo is a trademark and service mark of Emerson Electric Co. Brand logotype are registered trademarks of one of the Emerson family of companies. All other marks are the property of their respective owners. © 2019 Emerson Electric Co. All rights reserved.



CONSIDER IT SOLVED™