

## 系列 QR1



AVENTICS™

AVENTICS QR1 系列快插接头



## 系列 QR1

安沃驰 QR1 系列推入式接头安装便捷安全，提供多种型号：可用于 3 至 16 mm 的管道直径，还提供塑料、金属和不锈钢变型。QR1 系列的圆柱形螺纹可以重复连接和释放，不会出现问题（快速释放），固定式 O 型圈确保出色的密封性。我们的 QR 计划为各种应用和行业提供适当的解决方案。

- $Q_n = 60 \text{ l/min} \dots 875 \text{ l/min}$
- Na základě optimalizace produktu se může dodaný artikl akutálně odlišovat od zobrazených rozměrů.



QR1-S-RPN 标准系列

直接头  
外螺纹  
快插接头



G	Ø D	供货数量 [件]	物料号
M5	Ø 4	10	2121004050
M5	Ø 6	10	2121006050

2121004050

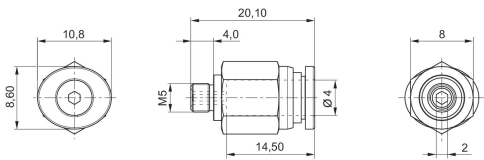

2121006050

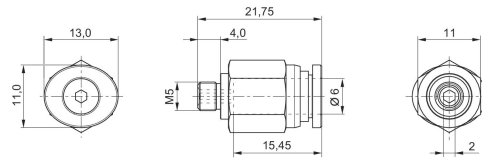

QR1-S-RPN 标准系列

直接头  
外螺纹  
快插接头



G	Ø D	供货数量 [件]	物料号
G 1/8	Ø 4	10	2121004180
G 1/8	Ø 6	10	2121006180
G 1/4	Ø 4	10	2121004140
G 1/4	Ø 6	10	2121006140
G 1/4	Ø 8	10	2121008140
G 3/8	Ø 6	10	R412005000
G 3/8	Ø 8	10	2121008380
G 3/8	Ø 10	10	2121010380
G 1/2	Ø 8	10	R412005001
G 1/2	Ø 10	10	2121010120
G 1/2	Ø 12	10	2121012120

2121004180

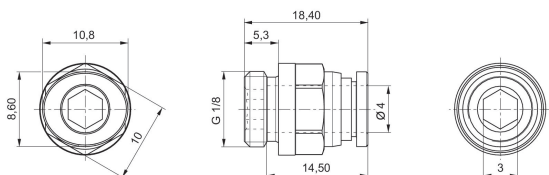

2121006180

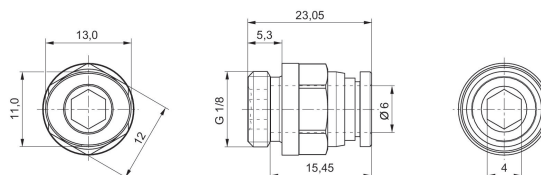

2121004140

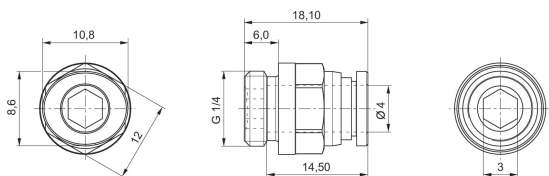

2121006140

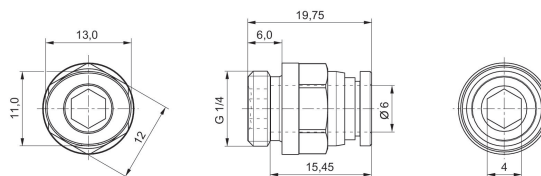



2121008140

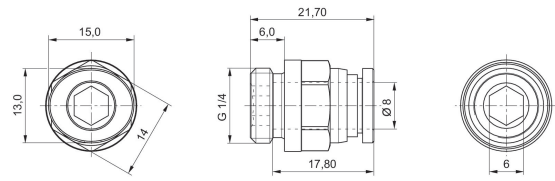

R412005000

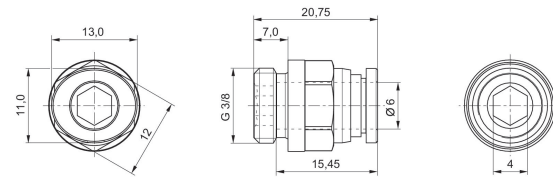

2121008380

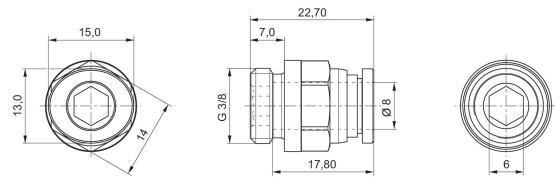

2121010380

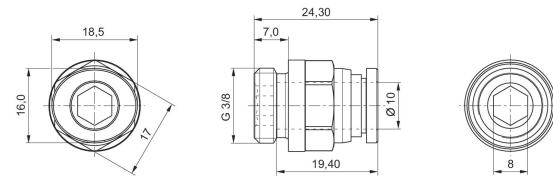

R412005001

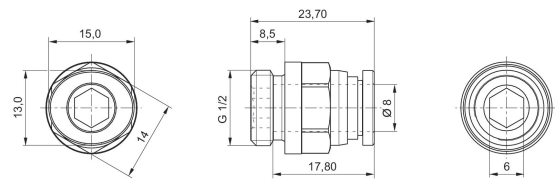

2121010120

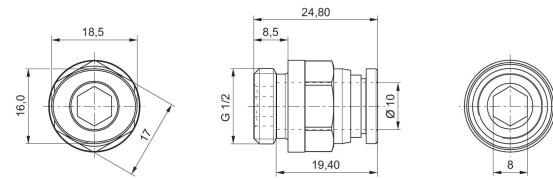

2121012120

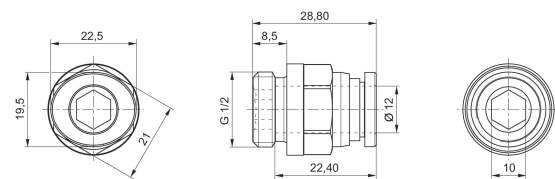

QR1-S-RPN 标准系列

直接头  
外螺纹  
快插接头

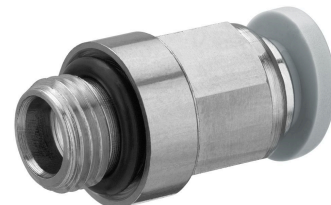

G	Ø D	供货数量 [件]	物料号
G 1/8	Ø 8	10	2121008180
G 1/8	Ø 10	10	R412005002
G 1/8	Ø 12	10	R412005003
G 1/4	Ø 10	10	2121010140
G 1/4	Ø 12	10	2121012140
G 3/8	Ø 12	10	2121012380
G 3/8	Ø 14	10	2121014380
G 3/8	Ø16	10	R412005005
G 1/2	Ø 14	10	2121014120
G 1/2	Ø16	10	R412005006

2121008180

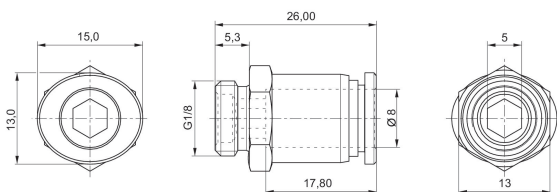

R412005002

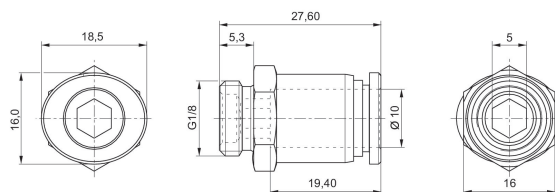

R412005003

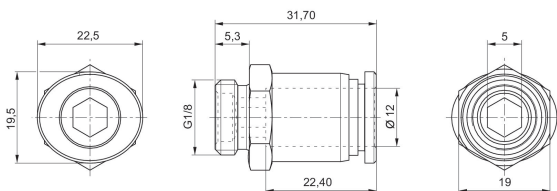

2121010140

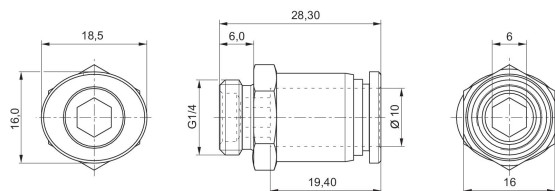

2121012140

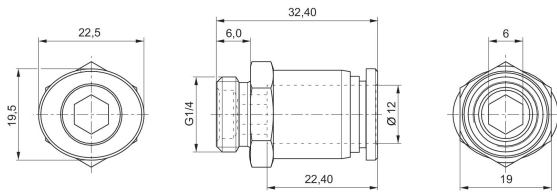

2121012380

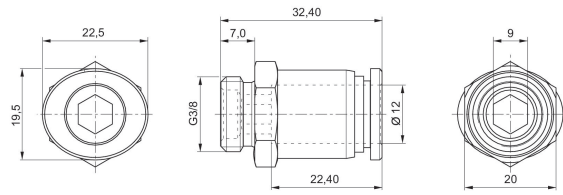

2121014380

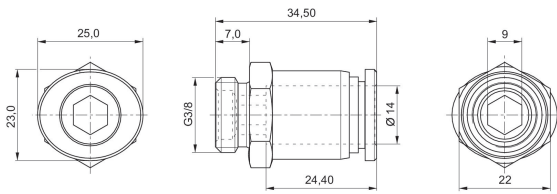

R412005005

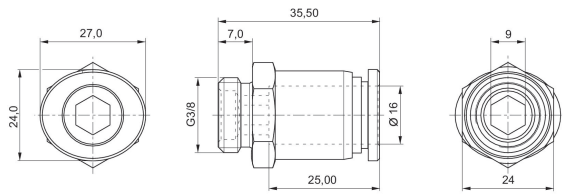

2121014120

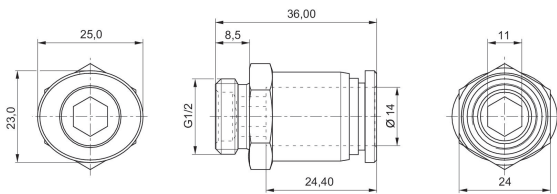

R412005006

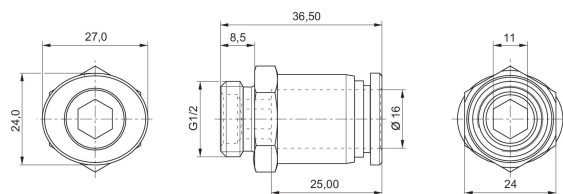

QR1-S-RAS 标准系列

插入式接头  
外螺纹  
针式衬套



G	Ø D	供货数量 [件]	物料号
M5	Ø 4	10	2121604050
M5	Ø 6	10	R412005068
G 1/8	Ø 4	10	2121604180
G 1/8	Ø 6	10	2121606180
G 1/8	Ø 8	10	R412005071
G 1/4	Ø 6	10	2121606140
G 1/4	Ø 8	10	2121608140
G 1/4	Ø 10	10	R412005072
G 1/4	Ø 12	10	R412005073
G 3/8	Ø 10	10	2121610380
G 3/8	Ø 12	10	R412005074
G 1/2	Ø 10	10	2121610120
G 1/2	Ø 12	10	2121612120
G 1/2	Ø 14	5	R412005076
G 1/2	Ø 16	5	R412005078

2121604050

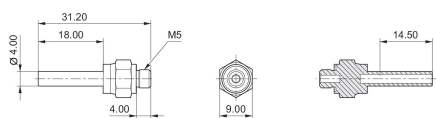

R412005068

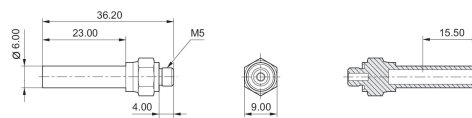

2121604180

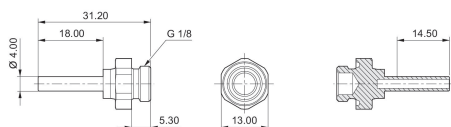

2121606180

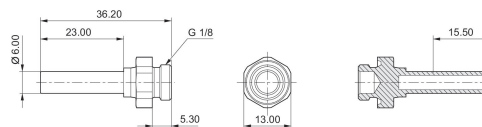

R412005071

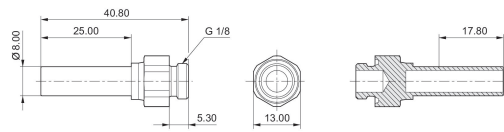

2121606140

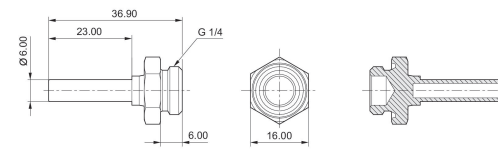

2121608140

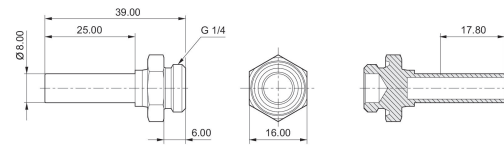

R412005072

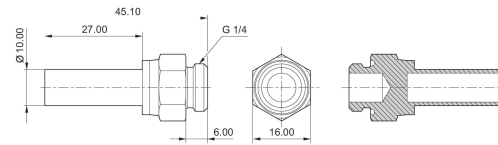

R412005073

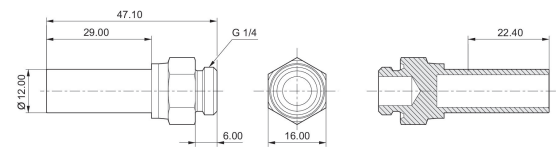

2121610380

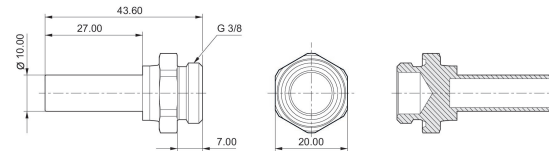

R412005074, 2121610120

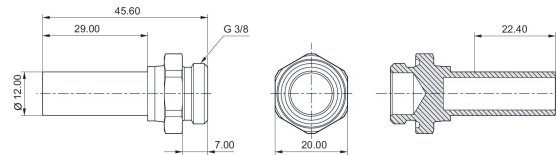

2121612120

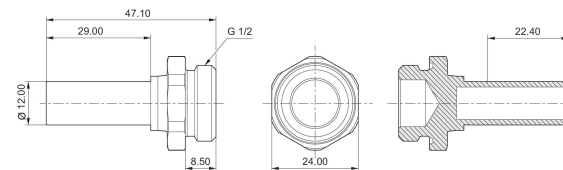

R412005076

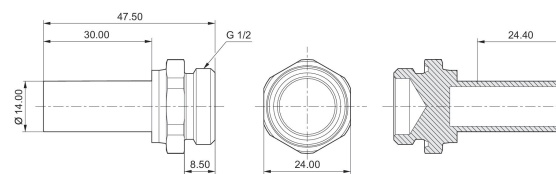

R412005078

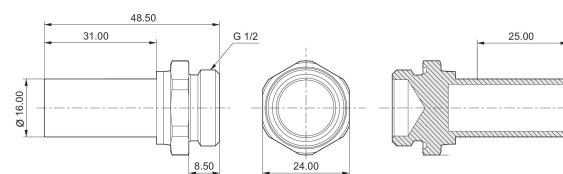

QR1-S-RAI 标准系列

带螺帽的直线型管接头  
内螺纹  
快插接头

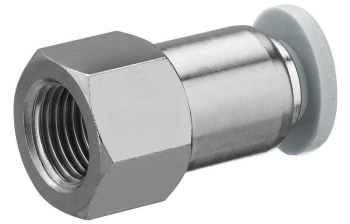

G	Ø D	供货数量 [件]	物料号
G 1/8	Ø 4	10	2121904180
G 1/8	Ø 6	10	2121906180
G 1/8	Ø 8	10	2121908180
G 1/4	Ø 4	10	R412005085
G 1/4	Ø 6	10	2121906140
G 1/4	Ø 8	10	2121908140
G 1/4	Ø 10	10	R412005089
G 1/4	Ø 12	10	R412005091
G 3/8	Ø 6	10	R412005086
G 3/8	Ø 8	10	R412005087
G 3/8	Ø 10	10	2121910380
G 3/8	Ø 12	10	2121912380
G 1/2	Ø 10	10	R412005090
G 1/2	Ø 12	10	2121912120

2121904180

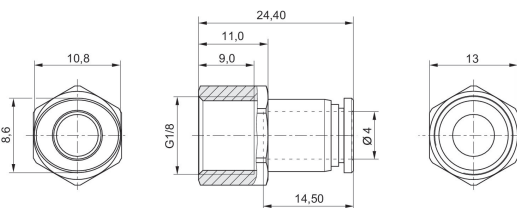

2121906180

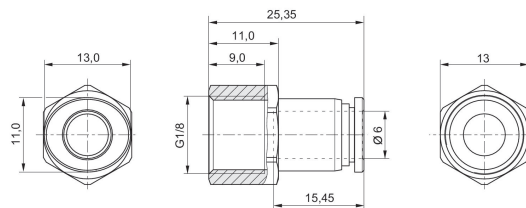

2121908180

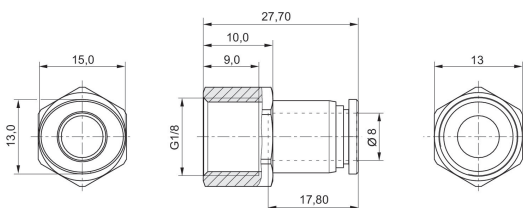

R412005085

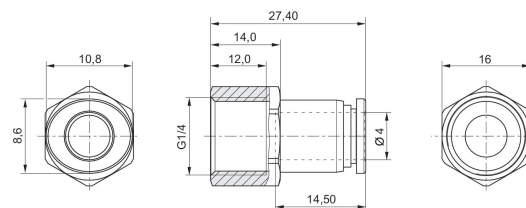



2121906140

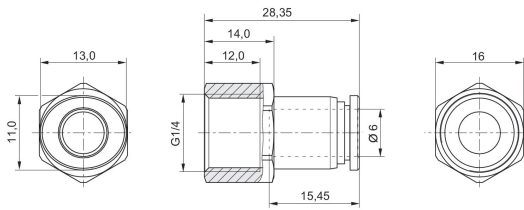

2121908140

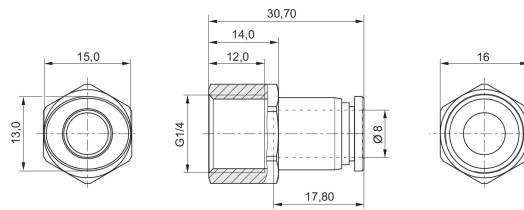

R412005089

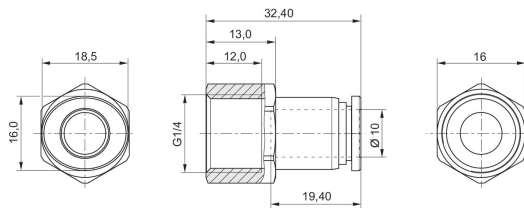

R412005091

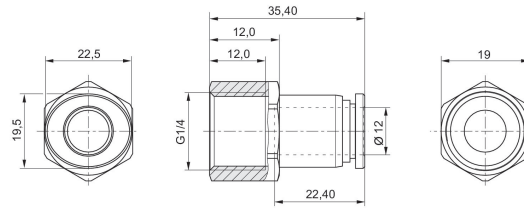

R412005086

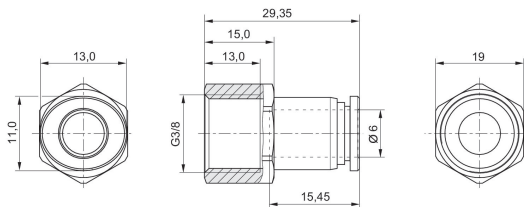

R412005087

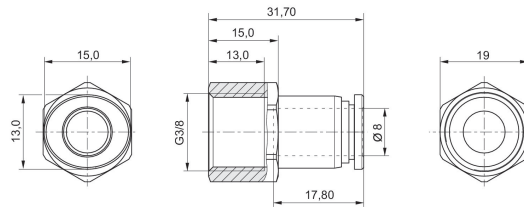

2121910380

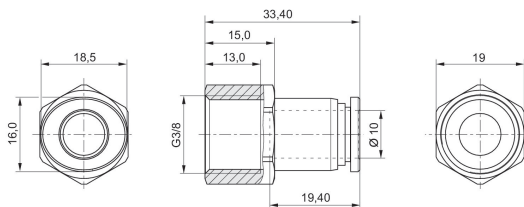

2121912380

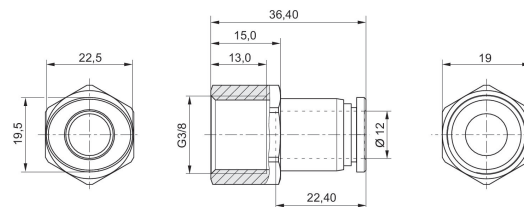

R412005090

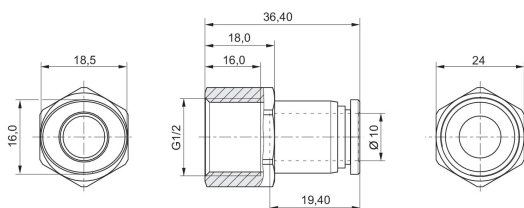

2121912120

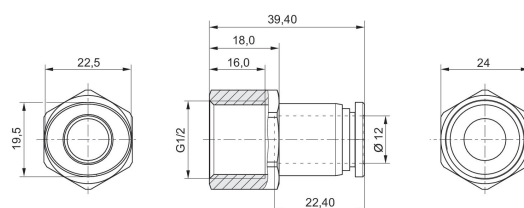

QR1-S-RSI 标准系列

隔板式管接头  
内螺纹  
快插接头

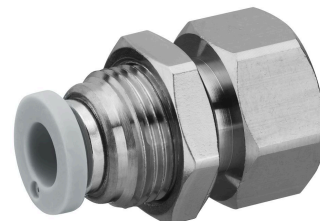

G	Ø D	供货数量 [件]	物料号
G 1/8	Ø 4	10	2122604180
G 1/8	Ø 6	10	2122606180
G 1/8	Ø 8	10	R412005232
G 1/4	Ø 6	10	2122606140
G 1/4	Ø 8	10	2122608140
G 1/4	Ø 10	10	R412005233
G 3/8	Ø 8	10	R412005231
G 3/8	Ø 10	10	2122610380
G 3/8	Ø 12	10	R412005235
G 1/2	Ø 12	10	2122612120

2122604180

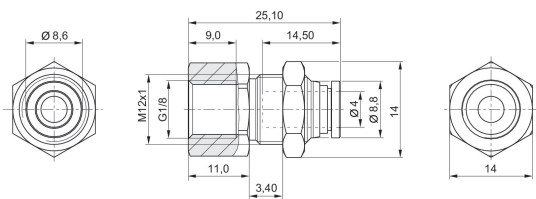

2122606180

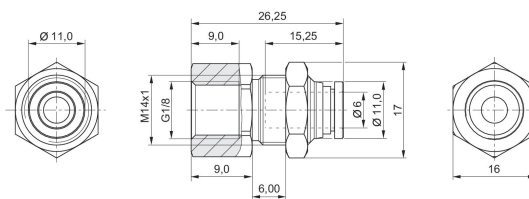

R412005232

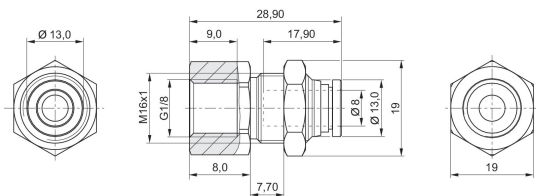

2122606140

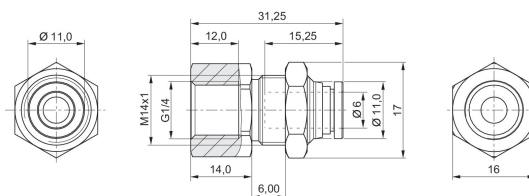

2122608140

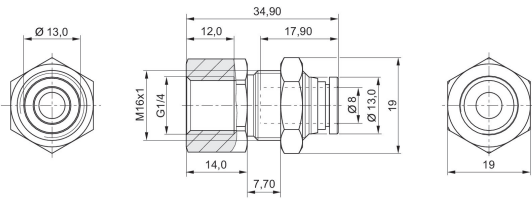

R412005233

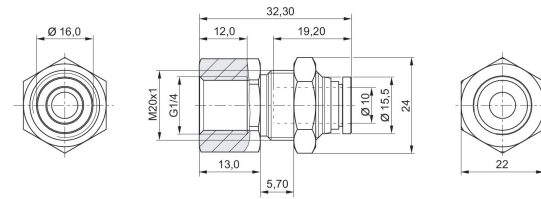

R412005231

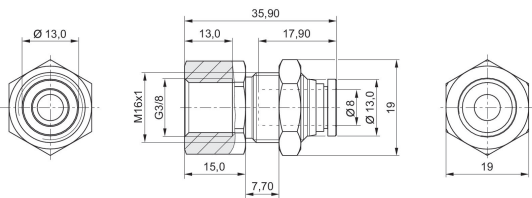

2122610380

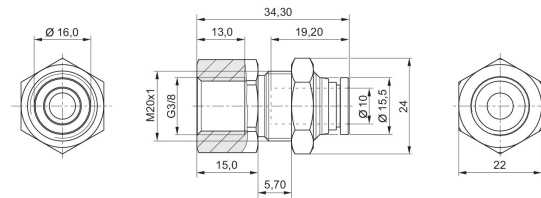

R412005235

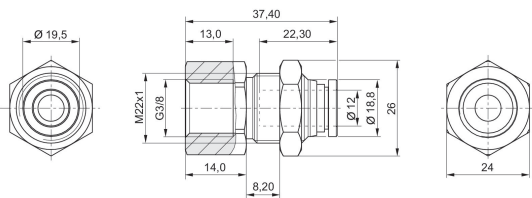

2122612120

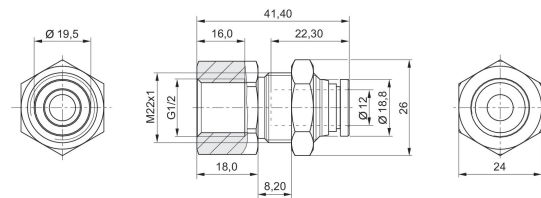

QR1-S-RVT 标准系列

弯头  
外螺纹  
快插接头



G	Ø D	供货数量 [件]	物料号
M5	Ø 4	10	2122004050
M5	Ø 6	10	2122006050

2122004050

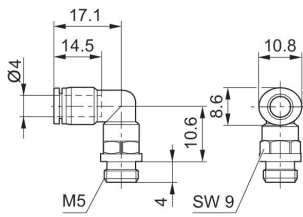

2122006050

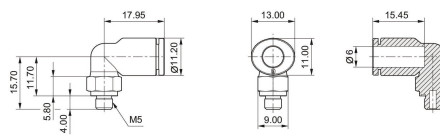

QR1-S-RVT 标准系列

弯头  
外螺纹  
快插接头



G	Ø D	供货数量 [件]	物料号
G 1/8	Ø 4	10	2122004180
G 1/8	Ø 6	10	2122006180
G 1/8	Ø 8	10	2122008180
G 1/8	Ø 10	10	R412005094
G 1/8	Ø 12	10	R412005095
G 1/4	Ø 4	10	2122004140
G 1/4	Ø 6	10	2122006140
G 1/4	Ø 8	10	2122008140
G 1/4	Ø 10	10	2122010140
G 1/4	Ø 12	10	2122012140
G 3/8	Ø 6	10	R412005092
G 3/8	Ø 8	10	2122008380
G 3/8	Ø 10	10	2122010380
G 3/8	Ø 12	10	2122012380
G 3/8	Ø 14	5	2122014380
G 3/8	Ø 16	5	R412005097
G 1/2	Ø 8	10	R412005093
G 1/2	Ø 10	10	2122010120
G 1/2	Ø 12	10	2122012120
G 1/2	Ø 14	5	2122014120
G 1/2	Ø 16	5	R412005098

2122004180

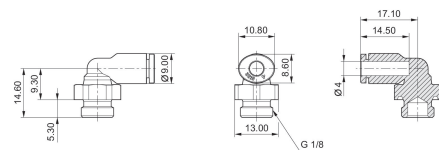

2122006180

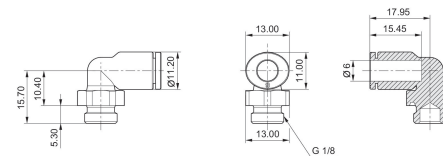

2122008180

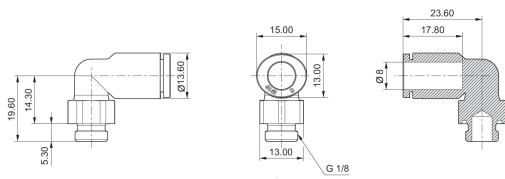

R412005094

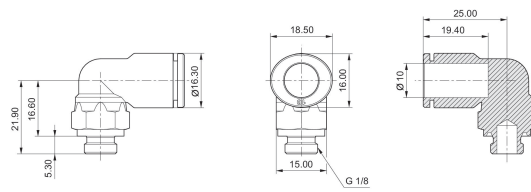

R412005095

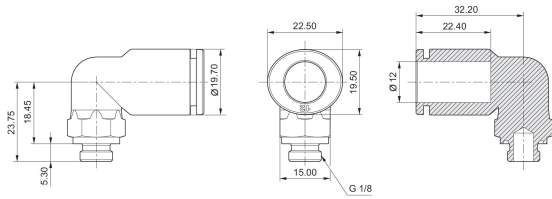

2122004140

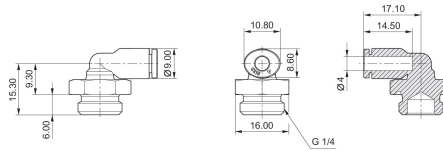

2122006140

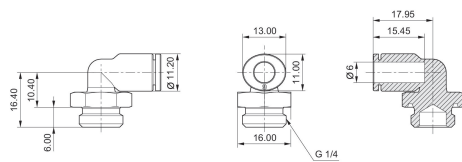

2122008140

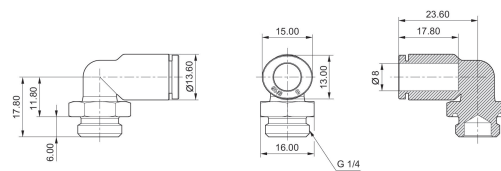

2122010140

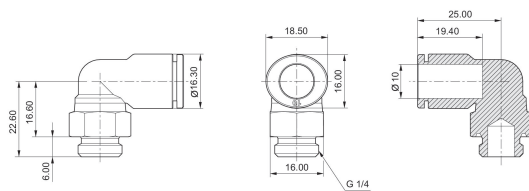

2122012140

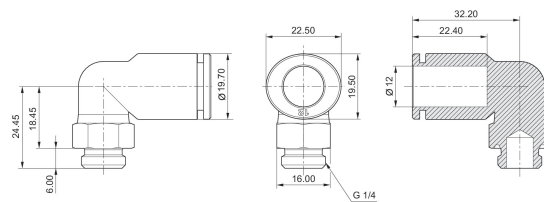

R412005092

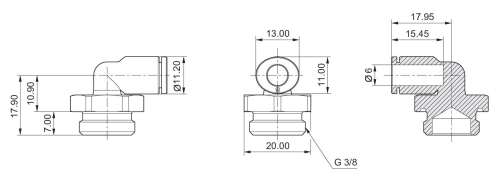

2122008380

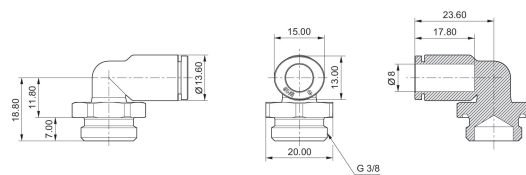



2122010380

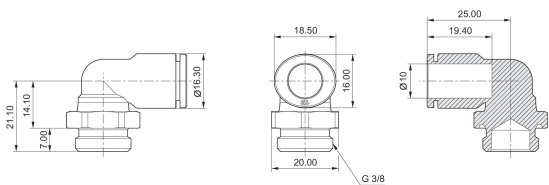

2122012380

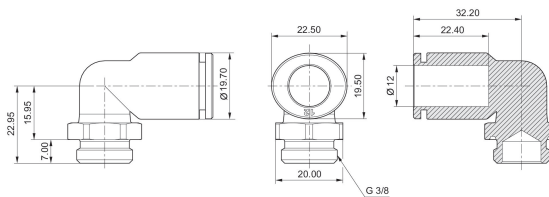

2122014380

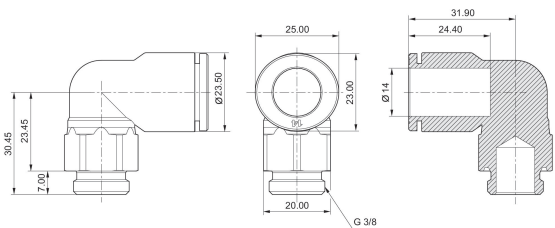

R412005097

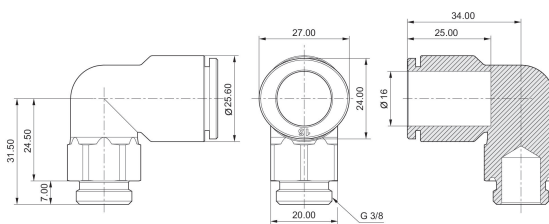

R412005093

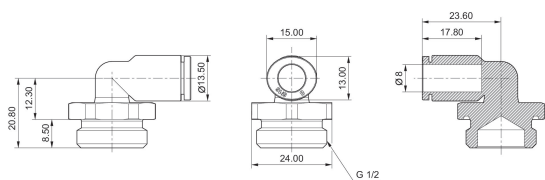

2122010120

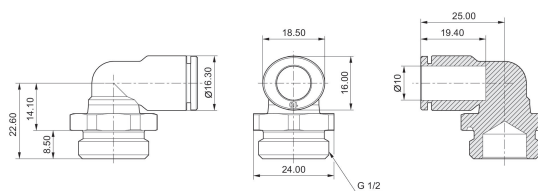

2122012120

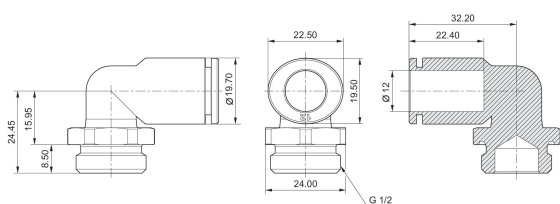

2122014120

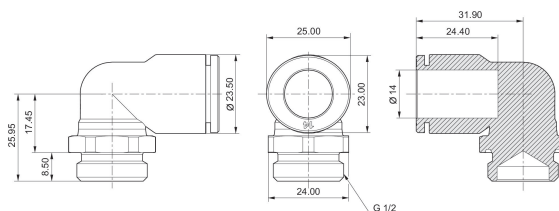

R412005098

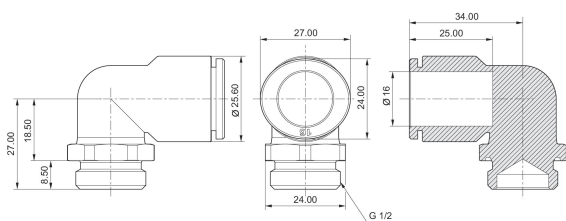

QR1-S-RVL 标准系列

长弯头  
外螺纹  
快插接头

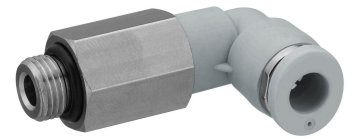

G	Ø D	供货数量 [件]	物料号
M5	Ø 4	10	2122104050
M5	Ø 6	10	R412005099
G 1/8	Ø 4	10	2122104180
G 1/8	Ø 6	10	2122106180
G 1/8	Ø 8	10	2122108180
G 1/4	Ø 4	10	2122104140
G 1/4	Ø 6	10	2122106140
G 1/4	Ø 8	10	2122108140
G 1/4	Ø 10	10	2122110140
G 1/4	Ø 12	10	R412005103
G 3/8	Ø 8	10	2122108380
G 3/8	Ø 10	10	2122110380
G 3/8	Ø 12	10	R412005104
G 1/2	Ø 12	10	R412005105

2122104050

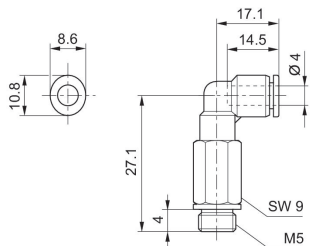

R412005099

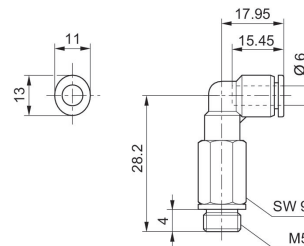

2122104180

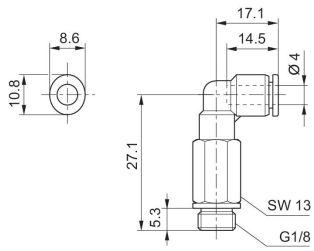

2122106180

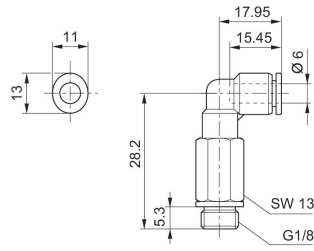

2122108180

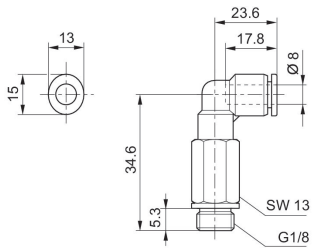

2122104140

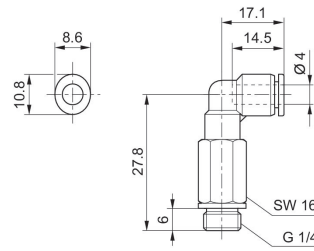

2122106140

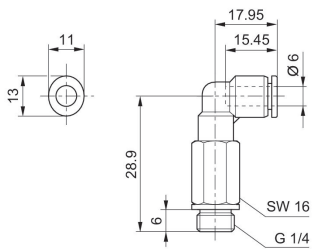

2122108140

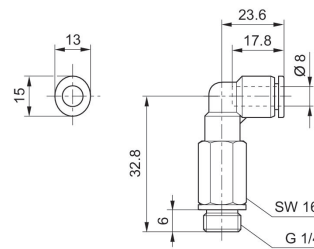

2122110140

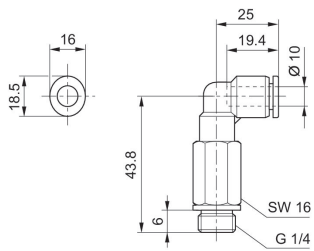

R412005103

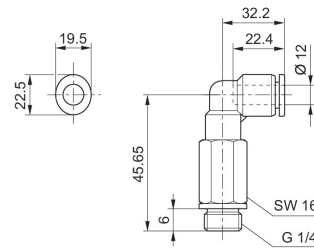

2122108380

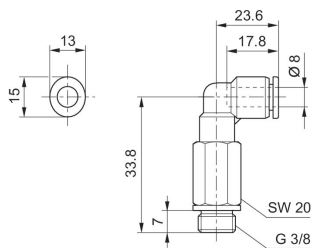

2122110380

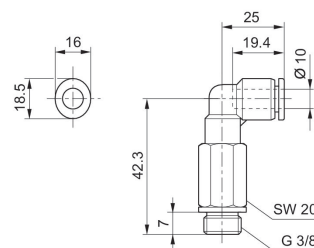

R412005104

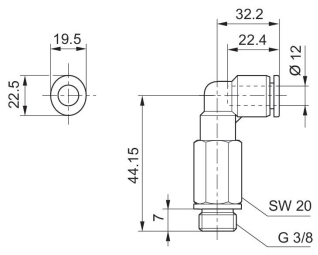

R412005105

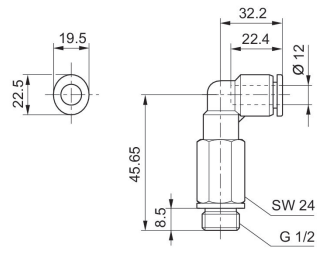

QR1-S-RVI 标准系列

母螺纹直角接头  
内螺纹  
快插接头

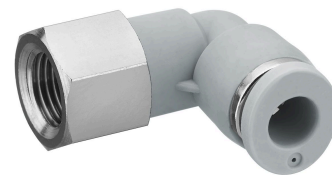

G	Ø D	供货数量 [件]	物料号
G 1/8	Ø 4	10	R412005129
G 1/8	Ø 6	10	R412005130
G 1/8	Ø 8	10	R412005131
G 1/4	Ø 4	10	R412005132
G 1/4	Ø 6	10	R412005133
G 1/4	Ø 8	10	R412005134
G 1/4	Ø 10	10	R412005135

R412005129

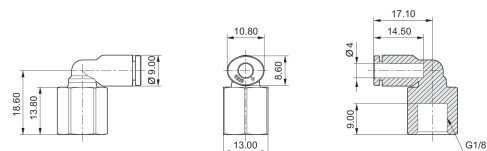

R412005130

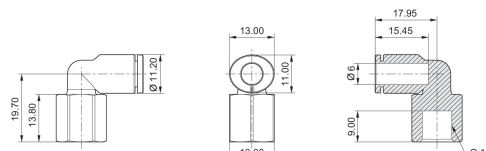

R412005131

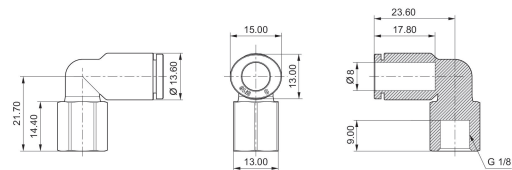

R412005132

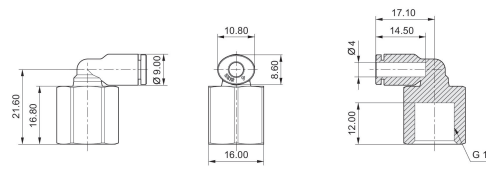

R412005133

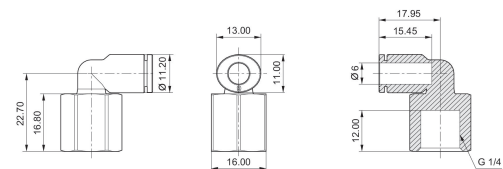

R412005134

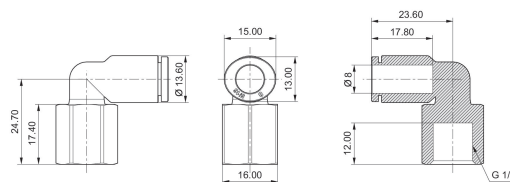

R412005135

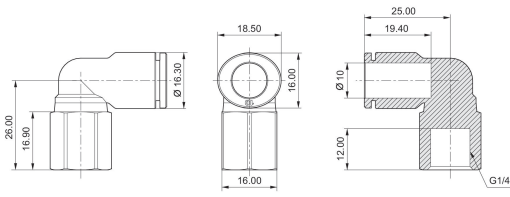



QR1-S-RW1 标准系列

角度回转接头 1倍  
外螺纹  
快插接头

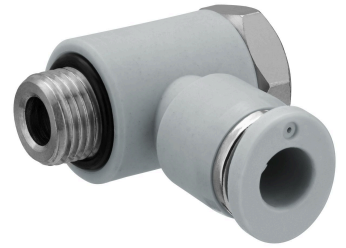

G	Ø D	供货数量 [件]	物料号
M5	Ø 4	10	R412005236
M5	Ø 6	10	R412005238

R412005236

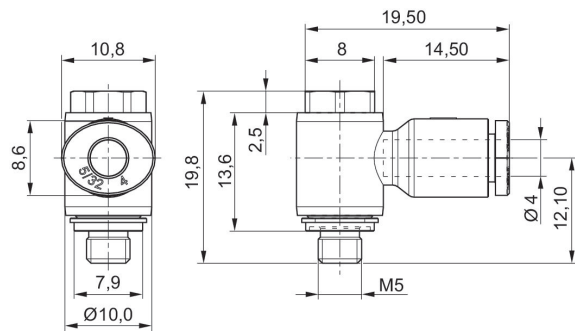

R412005238

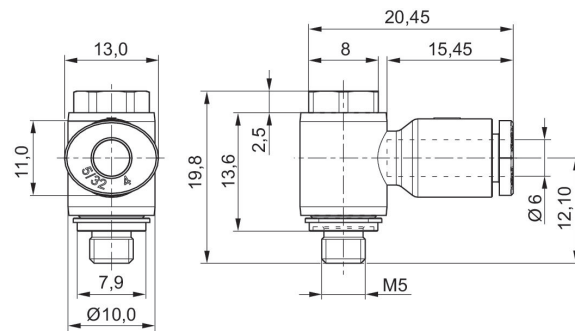

QR1-S-RW1 标准系列

角度回转接头 1倍  
外螺纹  
快插接头

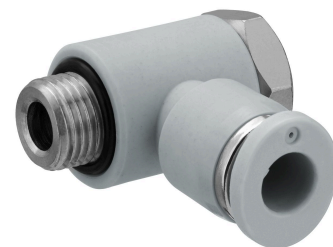

G	Ø D	供货数量 [件]	物料号
G 1/8	Ø 4	10	R412005237
G 1/8	Ø 6	10	R412005239
G 1/8	Ø 8	10	R412005240
G 1/4	Ø 6	10	R412005241
G 1/4	Ø 8	10	R412005242
G 1/4	Ø 10	10	R412005243
G 3/8	Ø 8	5	R412005244
G 3/8	Ø 10	5	R412005245
G 3/8	Ø 12	5	R412005246

R412005237

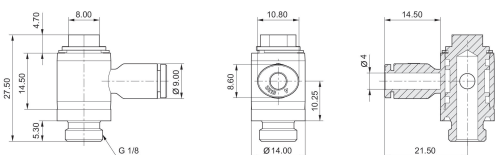

R412005239

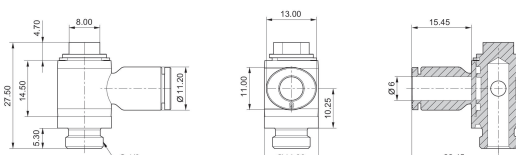

R412005240

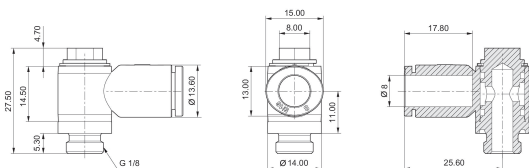

R412005241

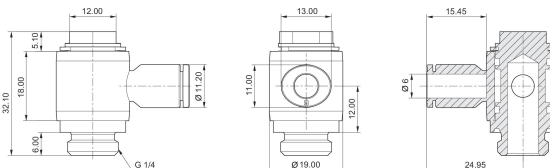

R412005242

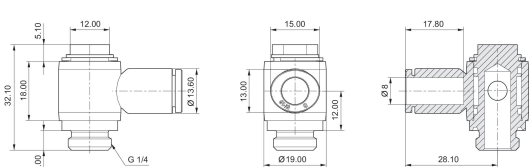

R412005243

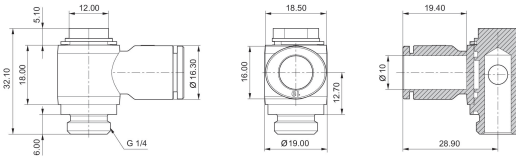

R412005244

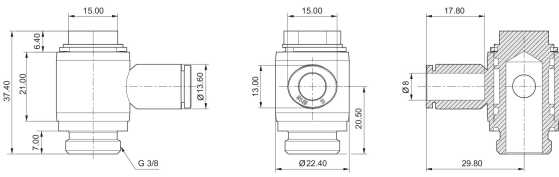

R412005245

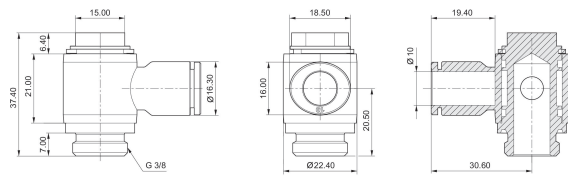

R412005246

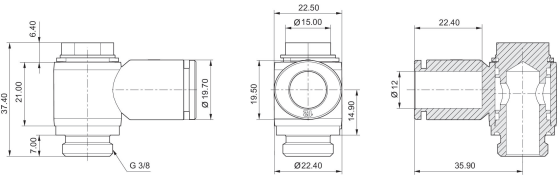

QR1-S-RW2 标准系列

角度回转接头 2倍  
外螺纹  
快插接头



G	Ø D	供货数量 [件]	物料号
G 1/8	Ø 4	10	R412005141
G 1/8	Ø 6	10	R412005144
G 1/8	Ø 8	10	R412005147
G 1/4	Ø 6	10	R412005145
G 1/4	Ø 8	10	R412005148
G 3/8	Ø 8	10	R412005149
G 3/8	Ø 10	5	R412005152
G 1/2	Ø 12	5	R412005155

R412005141

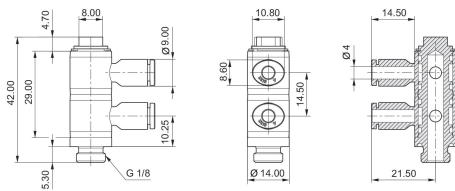

R412005144

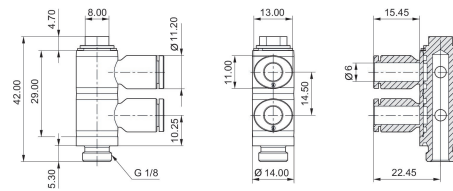

R412005147

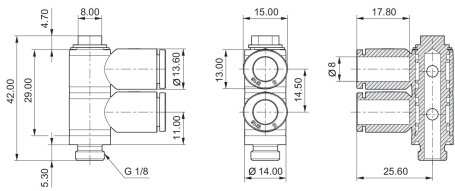

R412005145

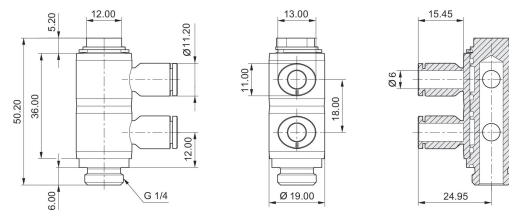

R412005148

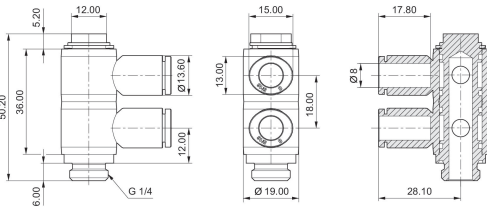

R412005149

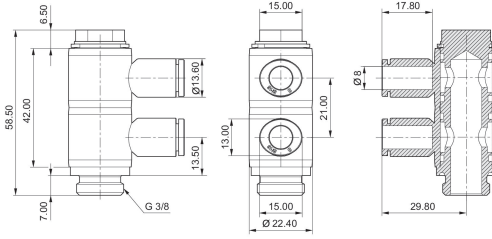

R412005152

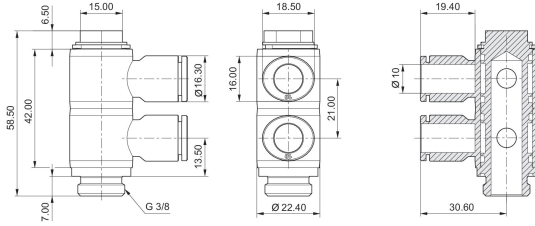

R412005155

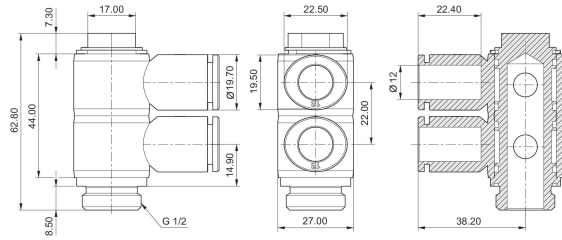

QR1-S-RW6 标准系列

角度回转接头 3倍,双面  
外螺纹  
快插接头



G	Ø D	供货数量 [件]	物料号
G 1/8	Ø 4	10	R412005186
G 1/8	Ø 6	10	R412005187
G 1/4	Ø 4	10	R412005189
G 1/4	Ø 6	10	R412005190
G 1/4	Ø 8	10	R412005191
G 3/8	Ø 6	10	R412005194
G 3/8	Ø 8	10	R412005195
G 3/8	Ø 10	5	R412005196

R412005186

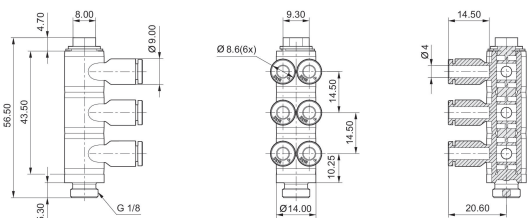

R412005187

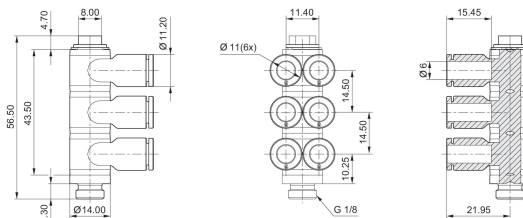

R412005189

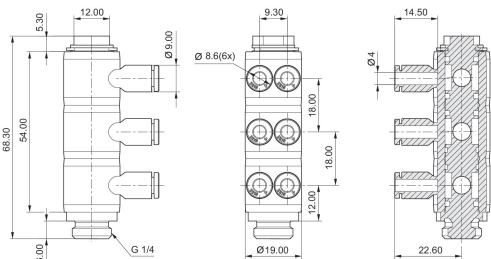

R412005190

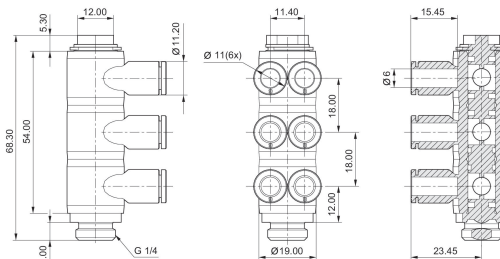



R412005191

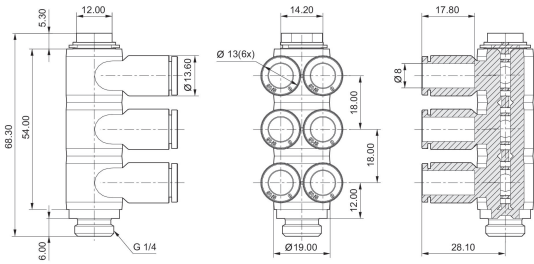

R412005194

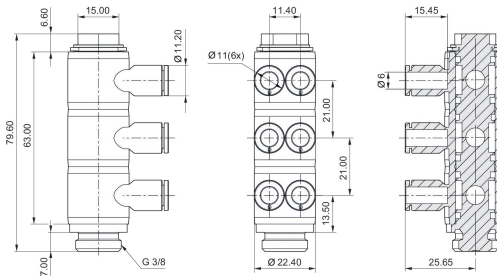

R412005195

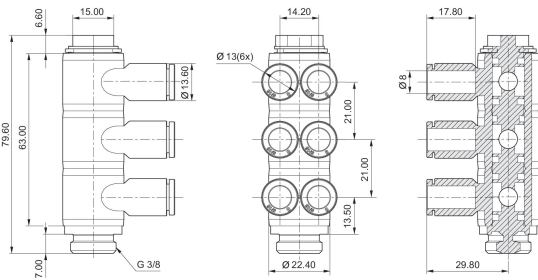

R412005196

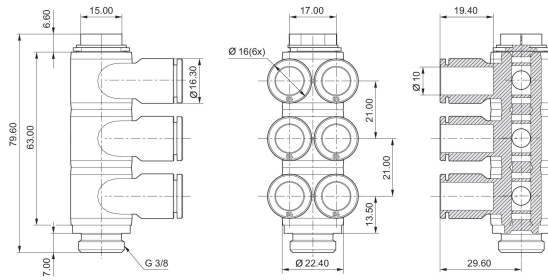

QR1-S-RID 标准系列

角度回转接头 2倍，配有内螺纹结构  
外螺纹  
快插接头



G	Ø D	Ø	供货数量 [件]	物料号
M5	Ø 4	M5	10	R412005259
G 1/8	Ø 6	G 1/8	10	R412005260
G 1/4	Ø 8	G 1/4	10	R412005261
G 3/8	Ø 10	G 3/8	5	R412005262

R412005259

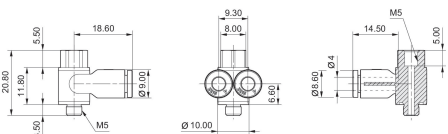

R412005260

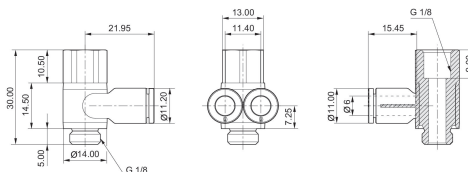

R412005261

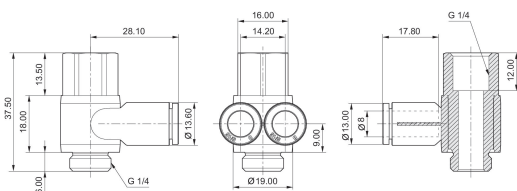

R412005262

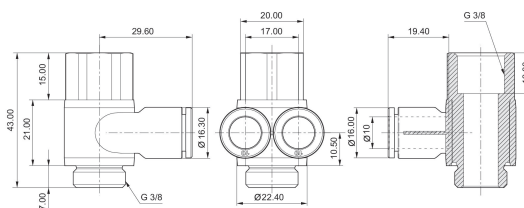

QR1-S-RTT 标准系列

T-接头  
外螺纹  
快插接头

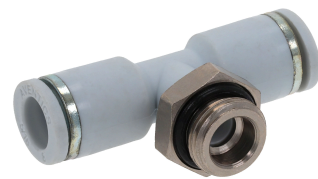

G	Ø D	供货数量 [件]	物料号
M5	Ø 4	10	2122204050
M5	Ø 6	10	R412005201
G 1/8	Ø 4	10	2122204180
G 1/8	Ø 6	10	2122206180
G 1/8	Ø 8	10	2122208180
G 1/8	Ø 10	10	R412005205
G 1/4	Ø 4	10	2122204140
G 1/4	Ø 6	10	2122206140
G 1/4	Ø 8	10	2122208140
G 1/4	Ø 10	10	2122210140
G 1/4	Ø 12	10	R412005206
G 3/8	Ø 6	10	R412005203
G 3/8	Ø 8	10	2122208380
G 3/8	Ø 10	10	2122210380
G 3/8	Ø 12	10	2122212380
G 3/8	Ø 14	10	2122214380
G 1/2	Ø 10	10	2122210120
G 1/2	Ø 12	5	2122212120
G 1/2	Ø 14	5	2122214120
G 1/2	Ø 16	5	R412005209

2122204050

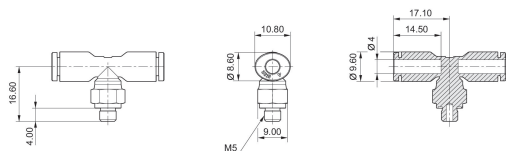

R412005201

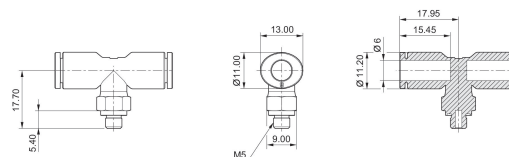

2122204180

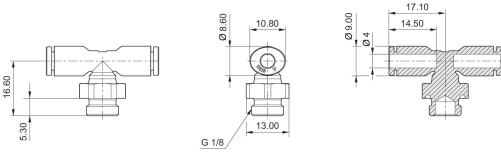

2122206180

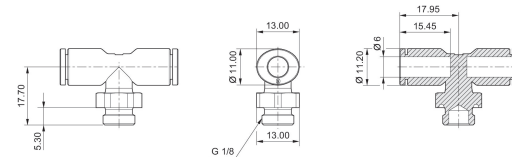

2122208180

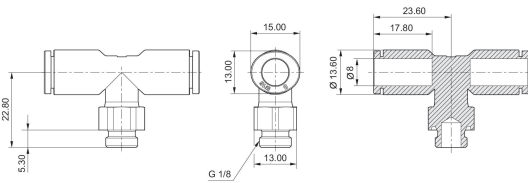

R412005205

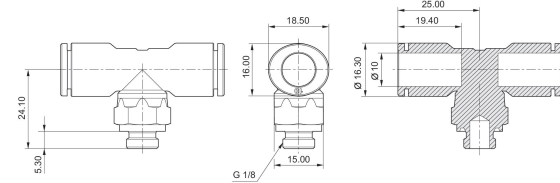

2122204140

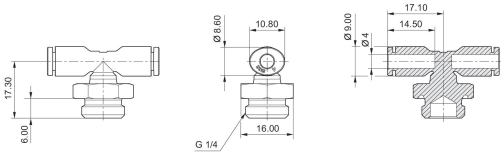

2122206140

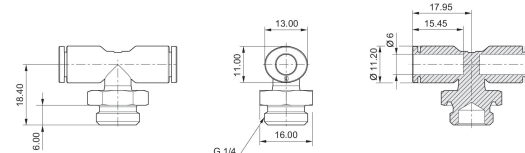

2122208140

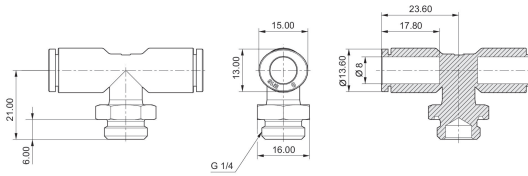

2122210140

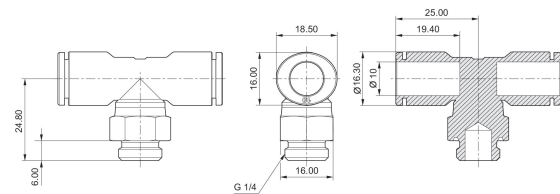

R412005206

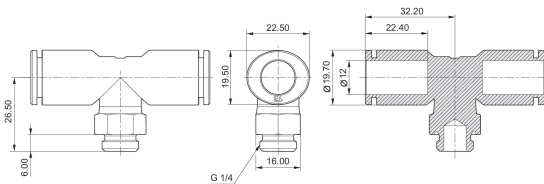

R412005203

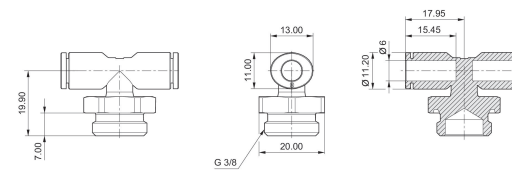

2122208380

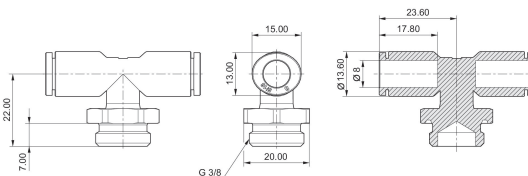

2122210380

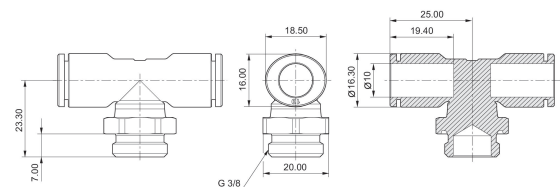

2122212380

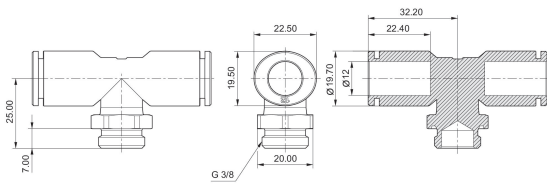

2122214380

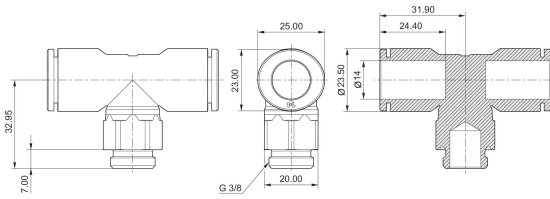

2122210120

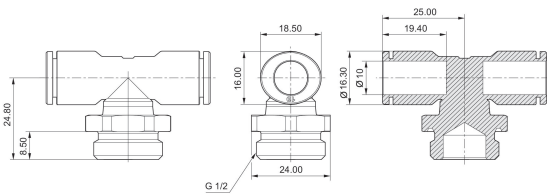

2122212120

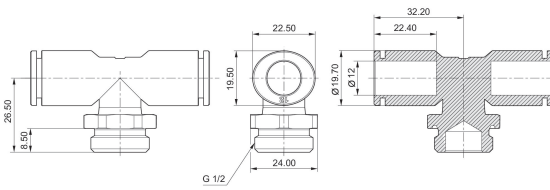

2122214120

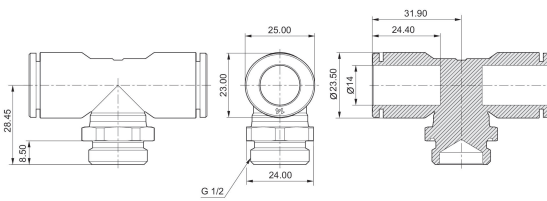

R412005209

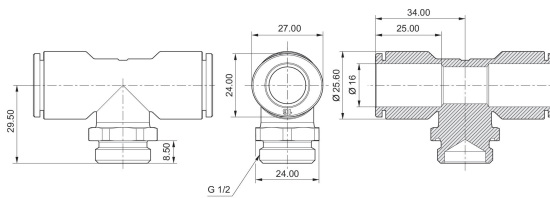

QR1-S-RTS 标准系列

T-旋转接头  
外螺纹  
快插接头

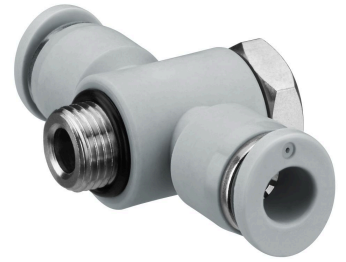

G	Ø D	供货数量 [件]	物料号
G 1/8	Ø 6	10	R412005292
G 1/8	Ø 8	10	R412005293
G 1/4	Ø 6	10	R412005294
G 1/4	Ø 8	10	R412005295

R412005292

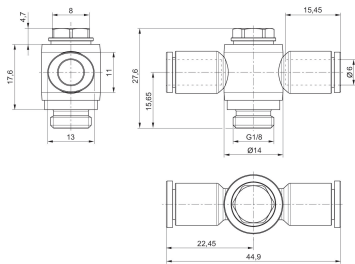

R412005293

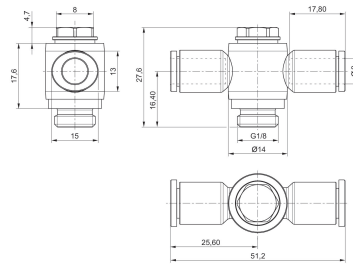

R412005294

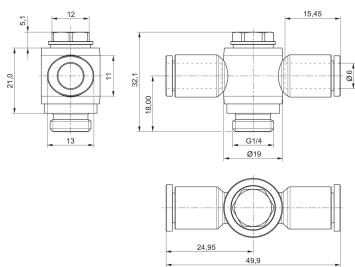

R412005295

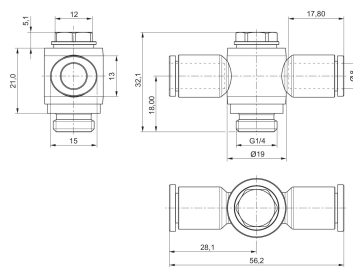

QR1-S-RLT 标准系列

弯形螺纹管接头  
外螺纹  
快插接头

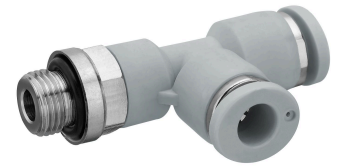

G	Ø D	供货数量 [件]	物料号
M5	Ø 4	10	2122304050
M5	Ø 6	10	R412005212
G 1/8	Ø 4	10	2122304180
G 1/8	Ø 6	10	2122306180
G 1/8	Ø 8	10	R412005214
G 1/4	Ø 4	10	R412005211
G 1/4	Ø 6	10	2122306140
G 1/4	Ø 8	10	2122308140
G 1/4	Ø 10	10	R412005215
G 1/4	Ø 12	5	R412005216
G 3/8	Ø 8	10	2122308380
G 3/8	Ø 10	10	2122310380
G 3/8	Ø 12	5	2122312380
G 1/2	Ø 10	10	2122310120
G 1/2	Ø 12	5	2122312120

2122304050

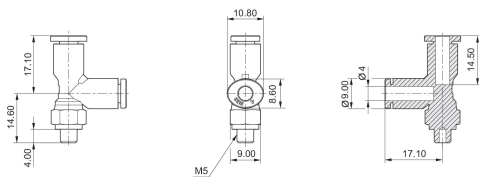

R412005212

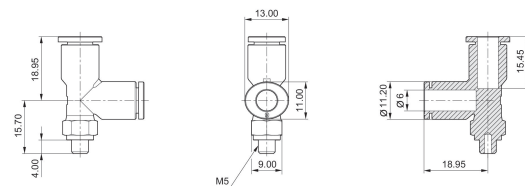

2122304180

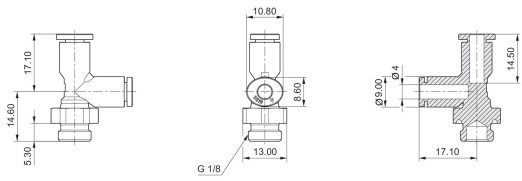

2122306180

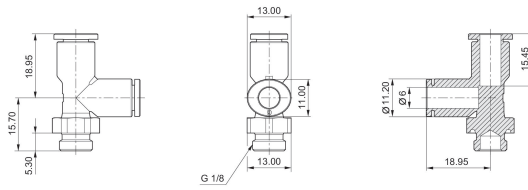

R412005214

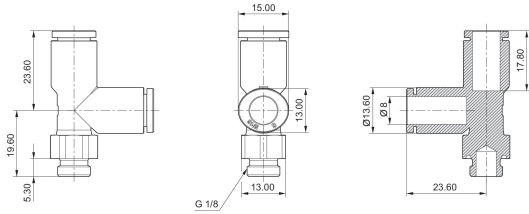

R412005211

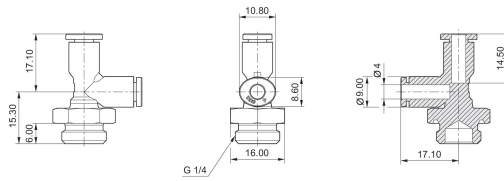

2122306140

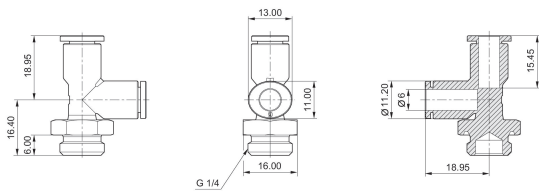

2122308140

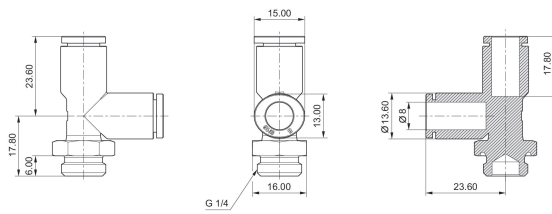

R412005215

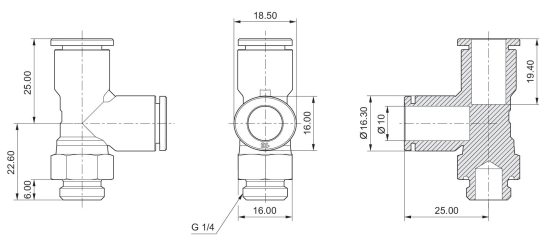

R412005216

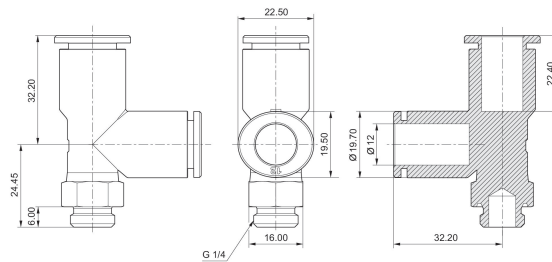

2122308380

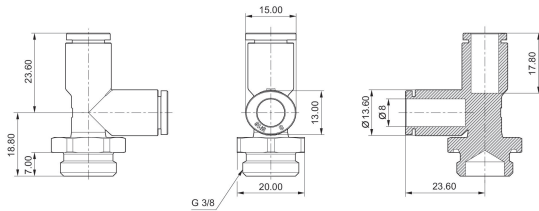

2122310380

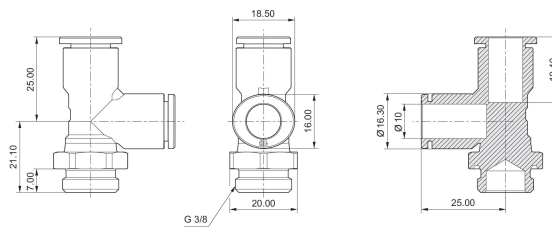



2122312380

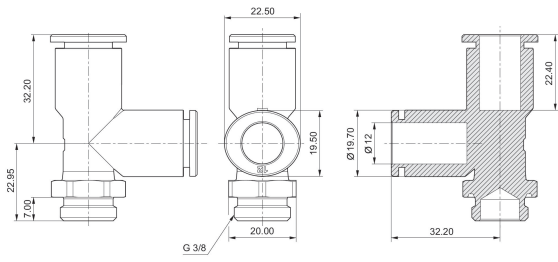

2122310120

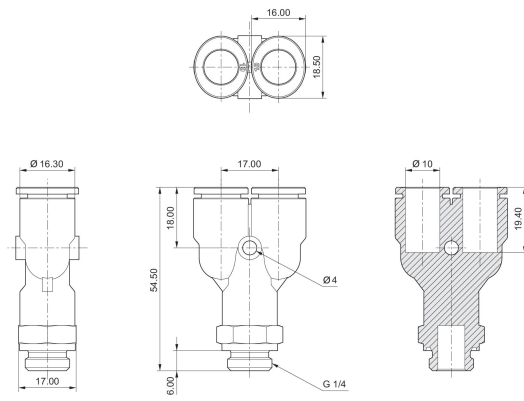

2122312120

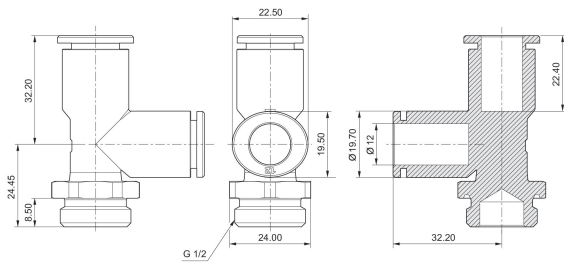

QR1-S-RAY 标准系列

Y型接头  
外螺纹  
快插接头



G	Ø D	供货数量 [件]	物料号
M5	Ø 4	10	2122404050
M5	Ø 6	10	R412005219
G 1/8	Ø 4	10	2122404180
G 1/8	Ø 6	10	2122406180
G 1/8	Ø 8	10	2122408180
G 1/4	Ø 4	10	2122404140
G 1/4	Ø 6	10	2122406140
G 1/4	Ø 8	10	2122408140
G 1/4	Ø 10	10	2122410140
G 3/8	Ø 8	10	R412005221
G 3/8	Ø 10	10	2122410380
G 3/8	Ø 12	10	2122412380
G 1/2	Ø 8	10	R412005222
G 1/2	Ø 10	10	2122410120
G 1/2	Ø 12	10	2122412120

2122404050

R412005219

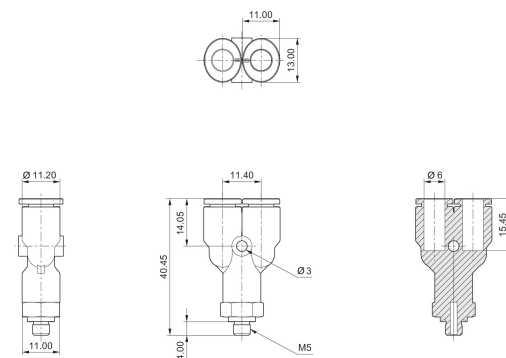
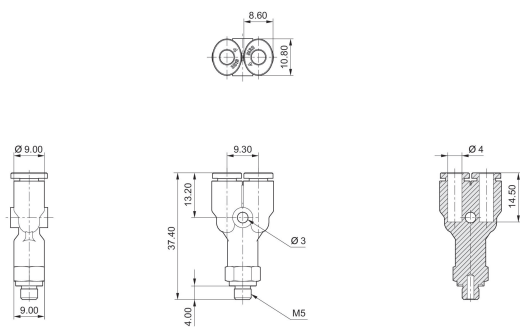

2122404180

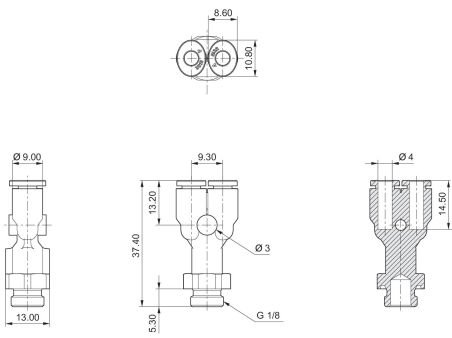

2122406180

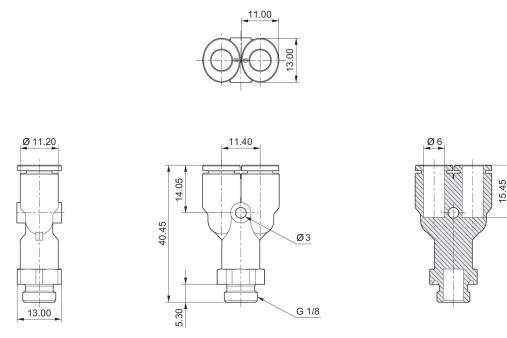

2122408180

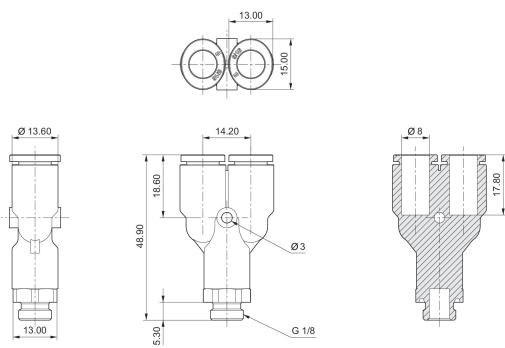

2122404140

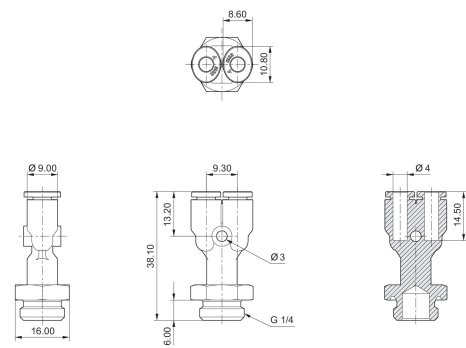

2122406140

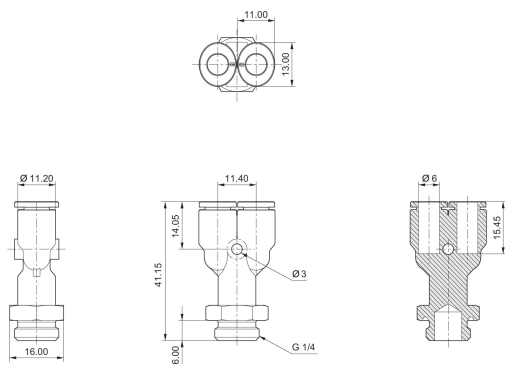

2122408140

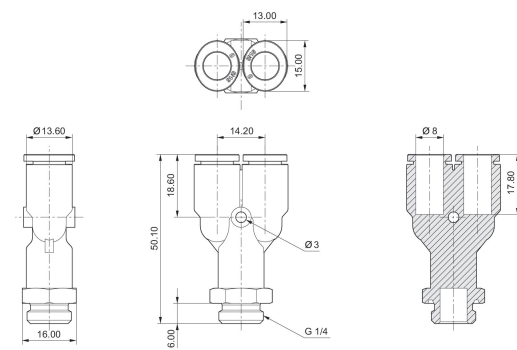

2122410140

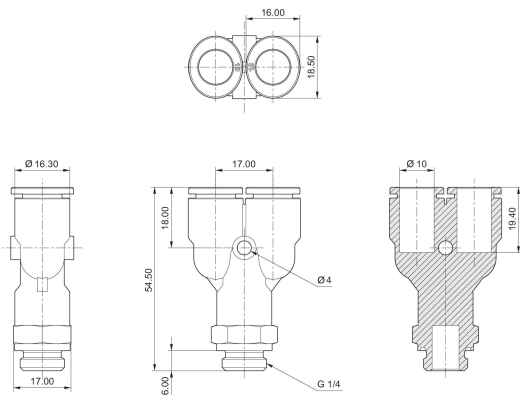

R412005221

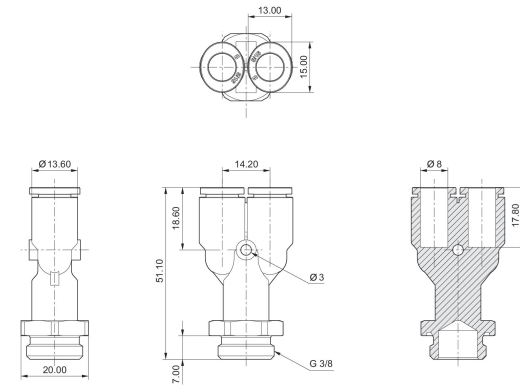

2122410380

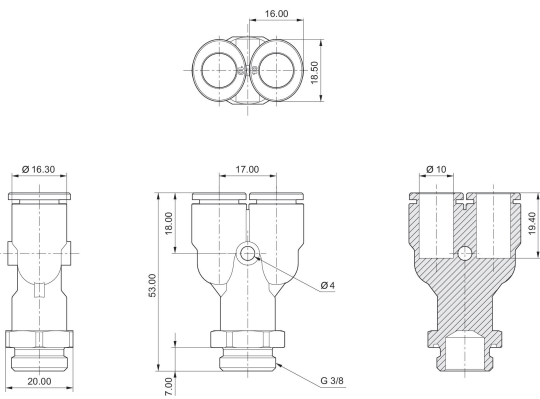

2122412380

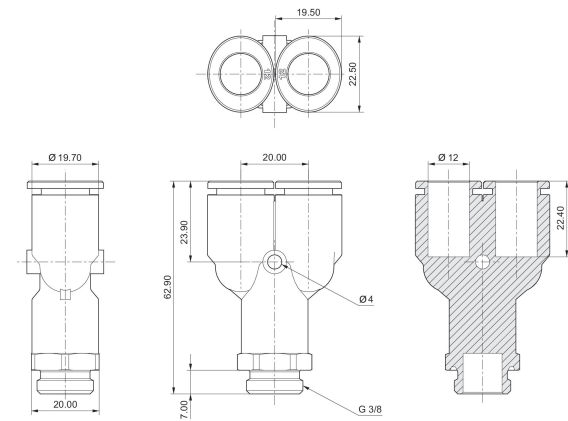

R412005222

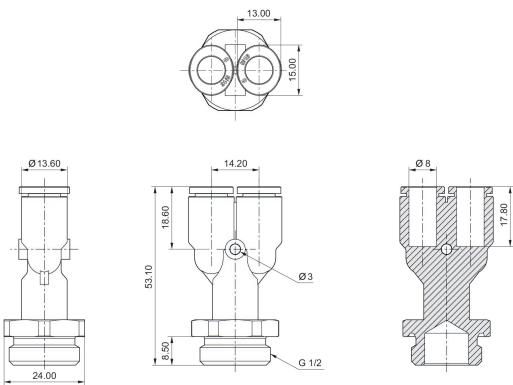

2122410120

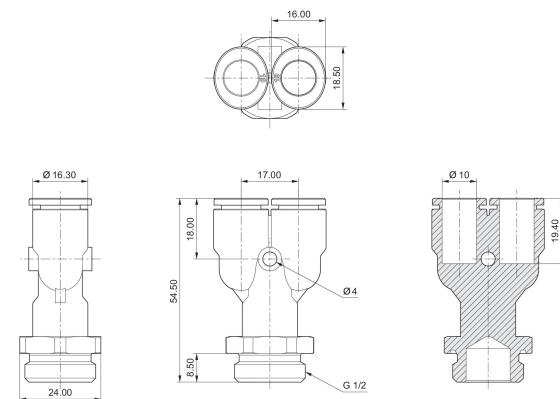

2122412120

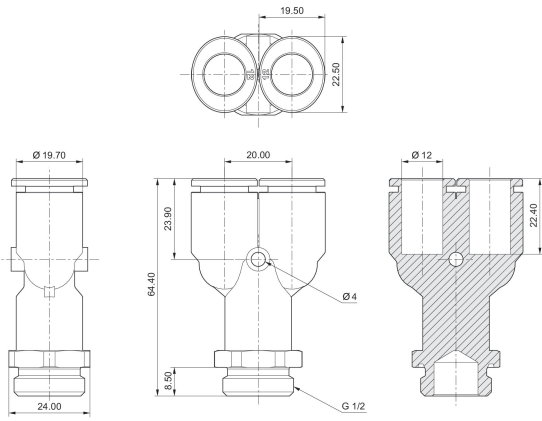

QR1-S-RSK 标准系列

锁母式直接头  
快插接头  
快插接头

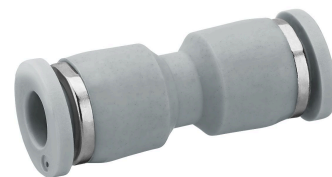

G	Ø D	供货数量 [件]	物料号
Ø 4	Ø 4	10	2121504000
Ø 6	Ø 6	10	2121506000
Ø 8	Ø 8	10	2121508000
Ø 10	Ø 10	10	2121510000
Ø 12	Ø 12	10	2121512000
Ø 14	Ø 14	5	2121514000
Ø 16	Ø 16	5	R412005059

2121504000

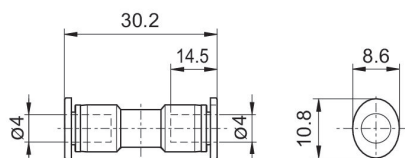

2121506000

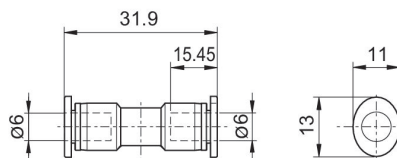

2121508000

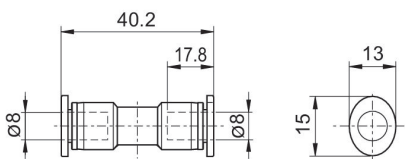

2121510000

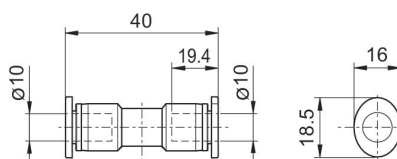

2121512000

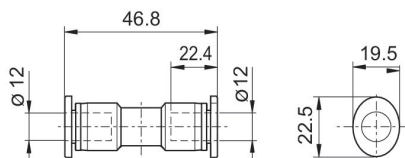

2121514000

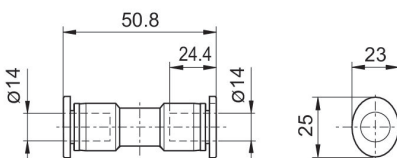

R412005059

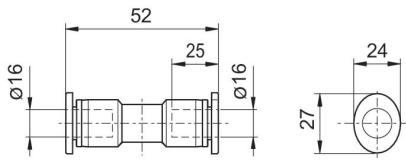

QR1-S-RSR 标准系列

直接头，缩径  
快插接头  
快插接头

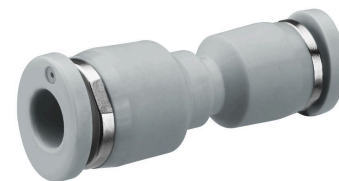

G	Ø D	供货数量 [件]	物料号
Ø 6	Ø 4	10	R412005060
Ø 8	Ø 4	10	R412005061
Ø 8	Ø 6	10	R412005062
Ø 10	Ø 6	10	R412005063
Ø 10	Ø 8	10	R412005064
Ø 12	Ø 8	10	R412005065
Ø 12	Ø 10	10	R412005066
Ø 16	Ø 12	5	R412005067

R412005060

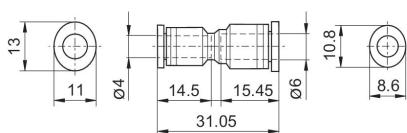

R412005061

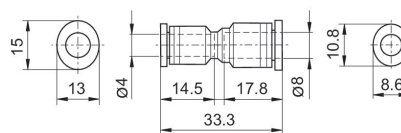

R412005062

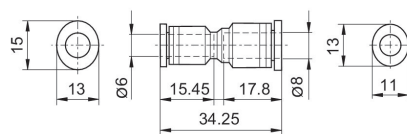

R412005063

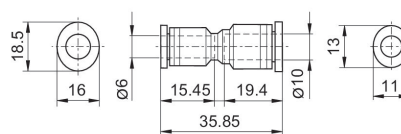

R412005064

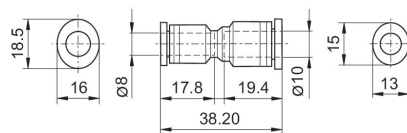

R412005065

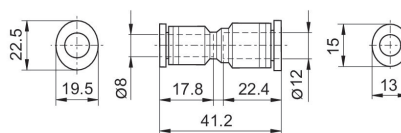

R412005066

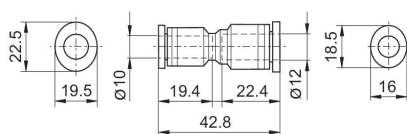

R412005067

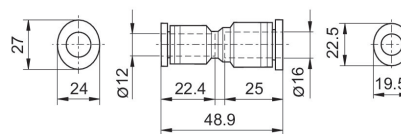



QR1-S-RSM 标准系列

隔板插接接口，金属  
快插接头  
快插接头



G	Ø D	供货数量 [件]	物料号
Ø 4	Ø 4	10	2121404000
Ø 6	Ø 6	10	2121406000
Ø 8	Ø 8	10	2121408000
Ø 10	Ø 10	10	2121410000
Ø 12	Ø 12	10	2121412000

2121404000

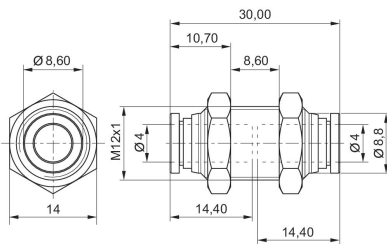

2121406000

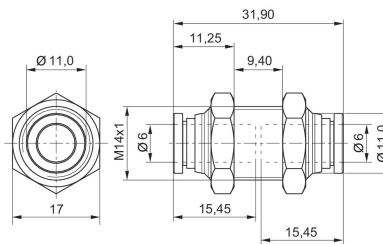

2121408000

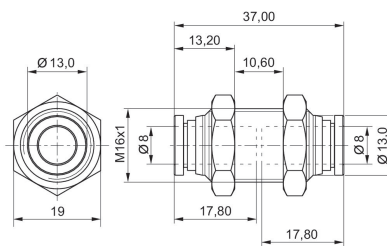

2121410000

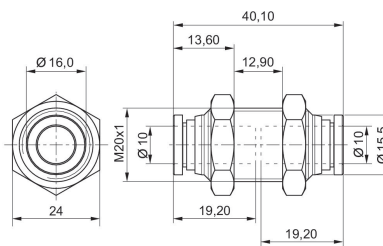

2121412000

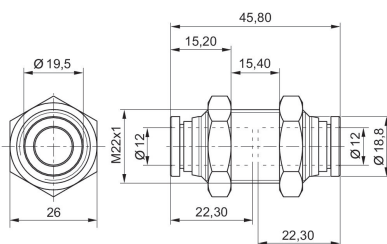

QR1-S-RSC 标准系列

隔墙连接插头，塑料材质  
快插接头  
快插接头



G	Ø D	供货数量 [件]	物料号
Ø 4	Ø 4	10	R412005051
Ø 6	Ø 6	10	R412005052
Ø 8	Ø 8	10	R412005053
Ø 10	Ø 10	10	R412005054
Ø 12	Ø 12	10	R412005055

R412005051

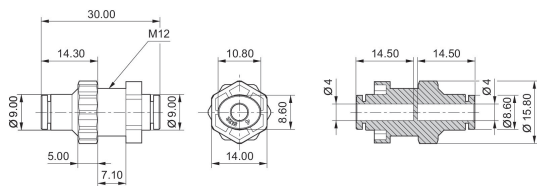

R412005052

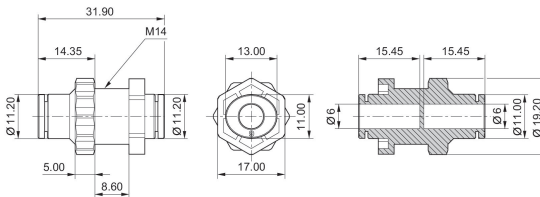

R412005053

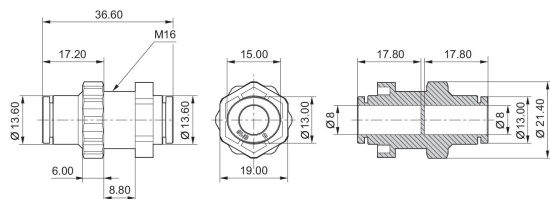

R412005054

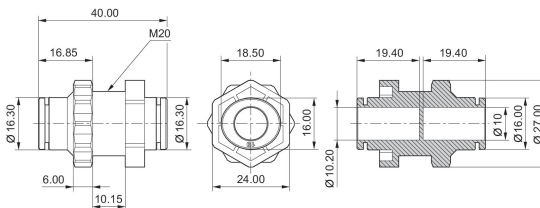

R412005055

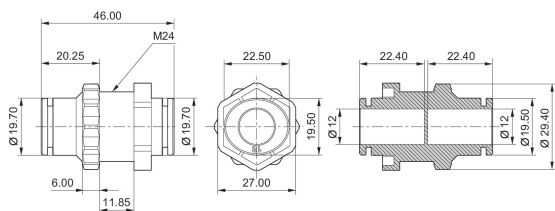

系列 QR1-S-RVW Mini

弯角连接插口  
针式衬套  
快插接头



G	Ø D	供货数量 [件]	物料号
Ø 4	Ø 4	10	R412005046

规格

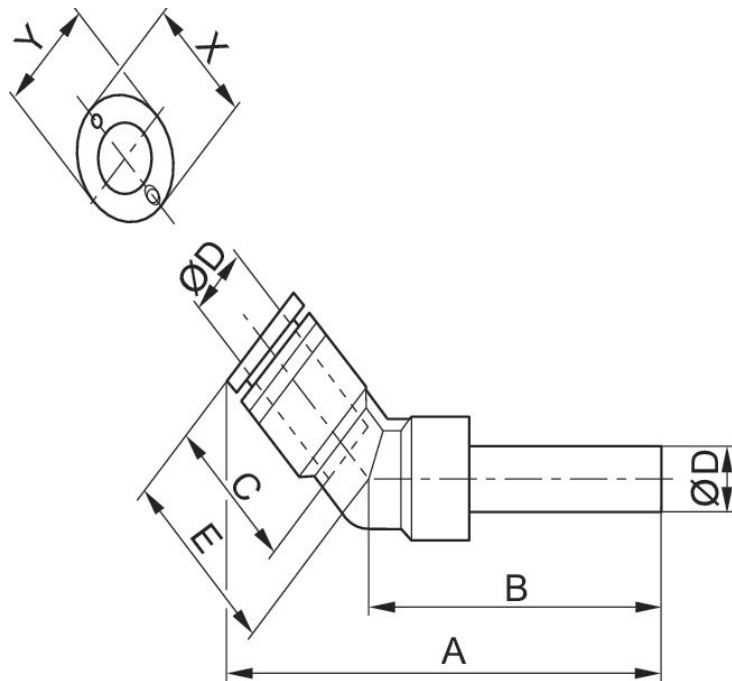

物料号	接口 D	接口 G	A	B	C	E	X	Y
R412005046	Ø 4	Ø 4	56,36	43,6	16	18.1	12	10

QR1-S-RVK 标准系列

弯角插头连接器  
快插接头  
快插接头

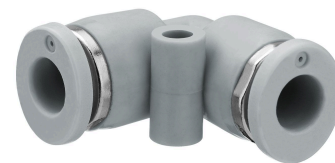

G	Ø D	供货数量 [件]	物料号
Ø 4	Ø 4	10	2121204000
Ø 6	Ø 6	10	2121206000
Ø 8	Ø 8	10	2121208000
Ø 10	Ø 10	10	2121210000
Ø 12	Ø 12	10	2121212000
Ø 14	Ø 14	5	2121214000
Ø 16	Ø 16	5	R412005033

2121204000

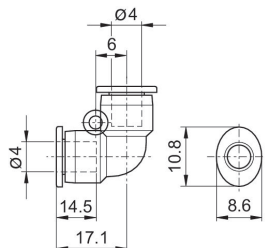

2121206000

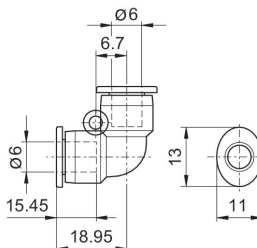

2121208000

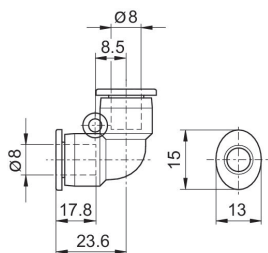

2121210000

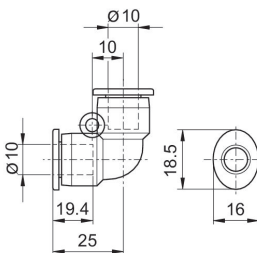

2121212000

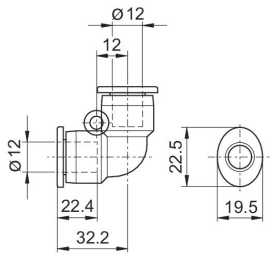

2121214000

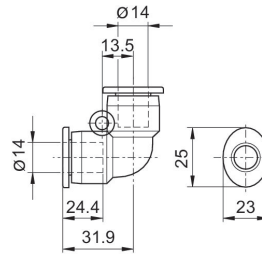

R412005033

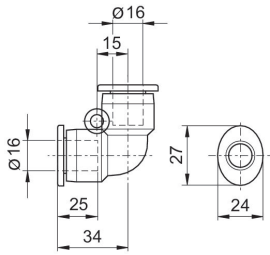

QR1-S-RVS 标准系列

弯角隔壁接头  
快插接头  
快插接头



G	Ø D	供货数量 [件]	物料号
Ø 4	Ø 4	10	R412005056
Ø 6	Ø 6	10	R412005057
Ø 8	Ø 8	10	R412005375
Ø 10	Ø 10	10	R412005376

R412005056

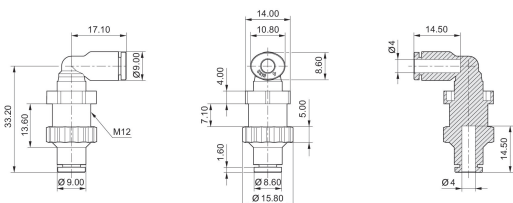

R412005057

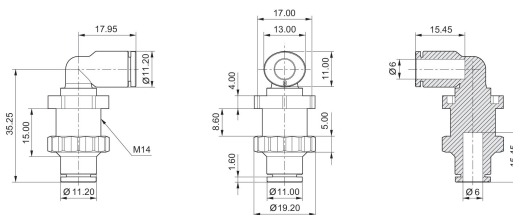

R412005375

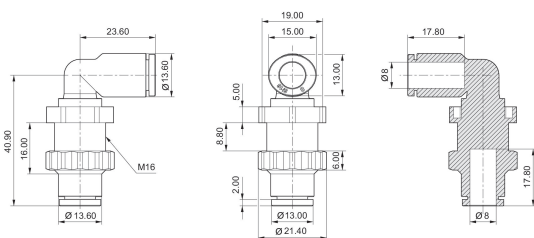

R412005376

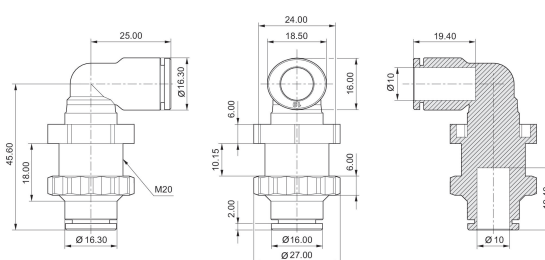

QR1-S-RMT 标准系列

3X 插头, 减径  
快插接头  
快插接头



G	Ø D	供货数量 [件]	物料号
Ø 6	Ø 4	10	R412005346
Ø 8	Ø 4	10	R412005347
Ø 8	Ø 6	10	R412005348
Ø 10	Ø 6	10	R412005349
Ø 10	Ø 8	10	R412005350

R412005346

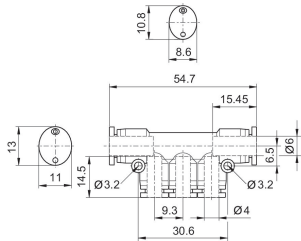

R412005347

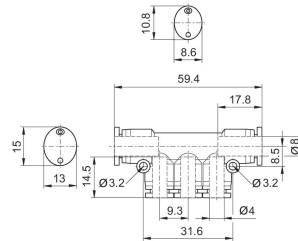

R412005348

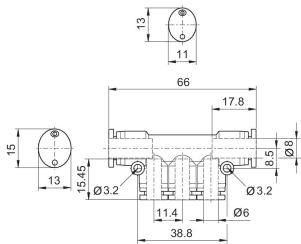

R412005349

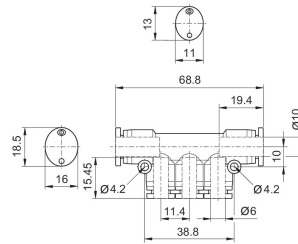

R412005350

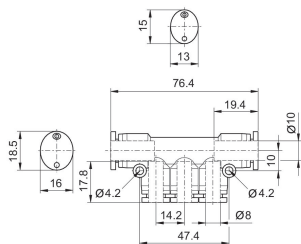

QR1-S-RTK 标准系列

T-插塞连接  
快插接头  
快插接头

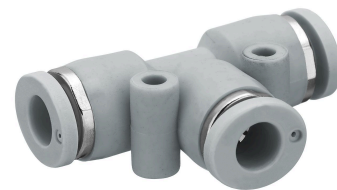

G	Ø D	供货数量 [件]	物料号
Ø 4	Ø 4	10	2121104000
Ø 6	Ø 6	10	2121106000
Ø 8	Ø 8	10	2121108000
Ø 10	Ø 10	10	2121110000
Ø 12	Ø 12	10	2121112000
Ø 14	Ø 14	5	2121114000
Ø 16	Ø 16	5	R412005025

2121104000

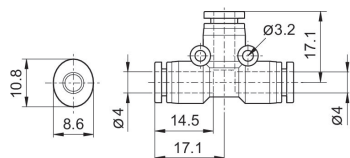

2121106000

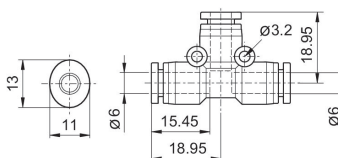

2121108000

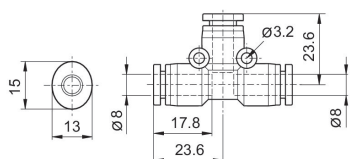

2121110000

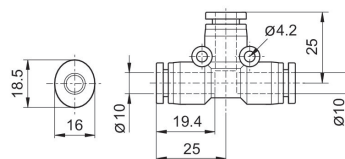

2121112000

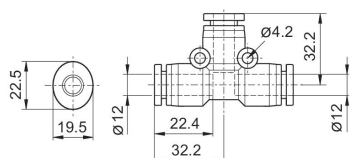

2121114000

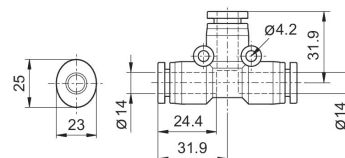



R412005025

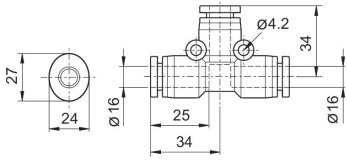

QR1-S-RTR 标准系列

T型连接接头，减径  
快插接头  
快插接头



G	Ø D	供货数量 [件]	物料号
Ø 6	Ø 4	10	R412005026
Ø 8	Ø 4	10	R412005027
Ø 8	Ø 6	10	R412005028
Ø 10	Ø 6	10	R412005029
Ø 10	M8	10	R412005030
Ø 12	Ø 8	10	R412005031
Ø 12	Ø 10	10	R412005032

R412005026

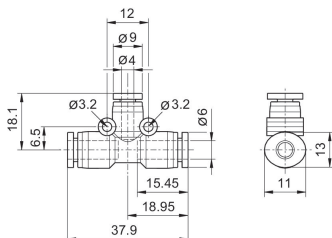

R412005027

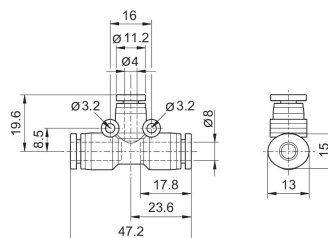

R412005028

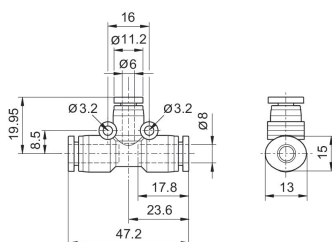

R412005029

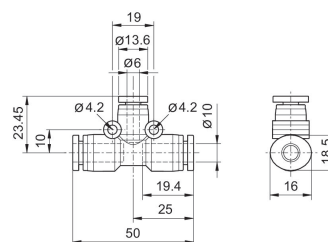

R412005030

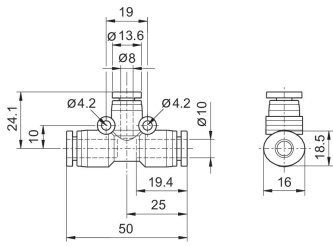

R412005031

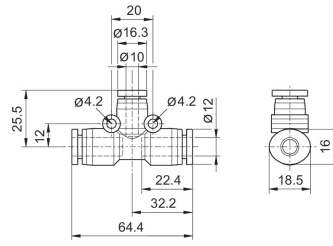

R412005032

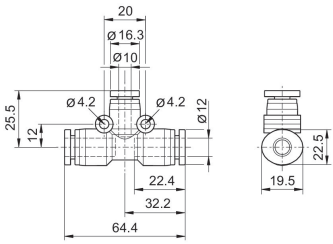

QR1-S-RYK 标准系列

Y-插头  
快插接头  
快插接头

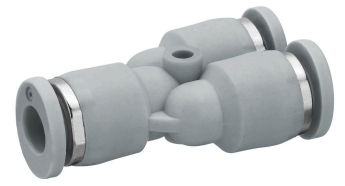

G	Ø D	供货数量 [件]	物料号
Ø 4	Ø 4	10	2121804000
Ø 6	Ø 6	10	2121806000
Ø 8	Ø 8	10	2121808000
Ø 10	Ø 10	10	2121810000
Ø 12	Ø 12	10	2121812000

2121804000

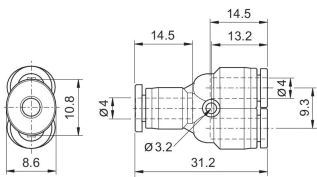

2121806000

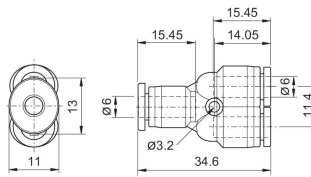

2121808000

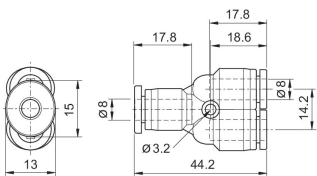

2121810000

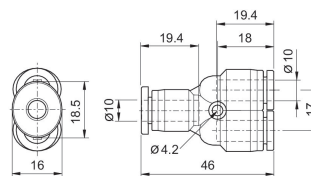

2121812000

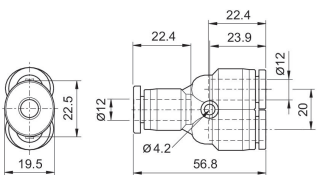

QR1-S-RYR 标准系列

Y型快插接头，减径  
快插接头  
快插接头

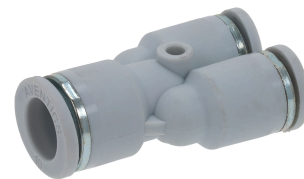

G	Ø D	供货数量 [件]	物料号
Ø 6	Ø 4	10	2121806040
Ø 8	Ø 4	10	R412005081
Ø 8	Ø 6	10	2121808060
Ø 10	Ø 6	10	R412005082
Ø 10	Ø 8	10	2121810080
Ø 12	Ø 8	10	R412005083
Ø 12	Ø 10	10	R412005080

2121806040

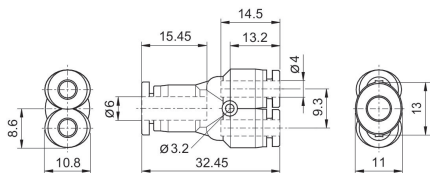

R412005081

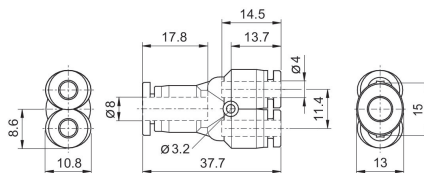

2121808060

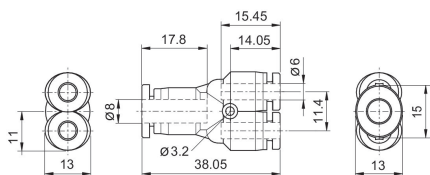

R412005082

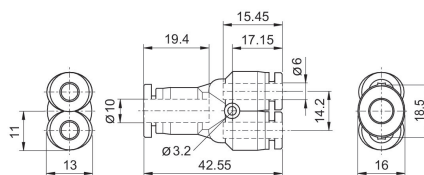

2121810080

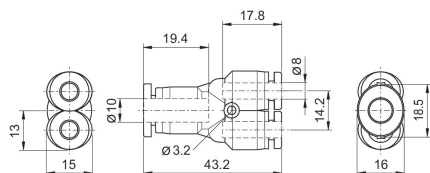

R412005083

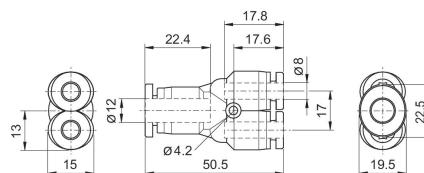

R412005080

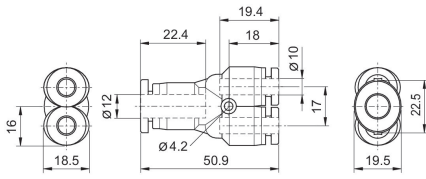

QR1-S-RYD 标准系列

Y型快插接头，减径  
双重  
快插接头  
快插接头

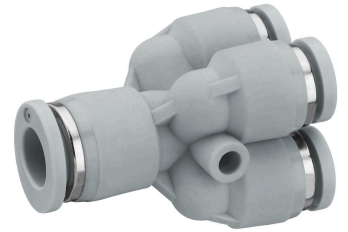

G	Ø D	供货数量 [件]	物料号
Ø 6	Ø 4	10	R412005344
Ø 8	Ø 6	10	R412005345

R412005344

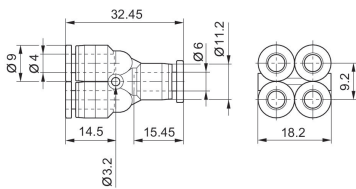

R412005345

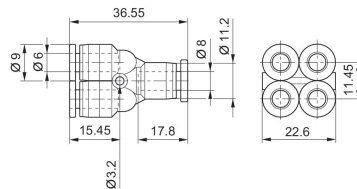

QR1-S-RXS 标准系列

X-插头  
快插接头  
快插接头



G	Ø D	供货数量 [件]	物料号
Ø 4	Ø 4	10	R412005361
Ø 6	Ø 6	10	R412005362
Ø 8	Ø 8	10	R412005363
Ø 10	Ø 10	10	R412005364

R412005361

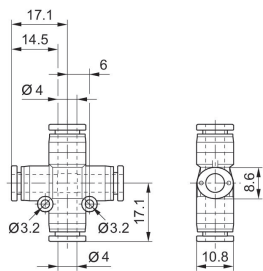

R412005362

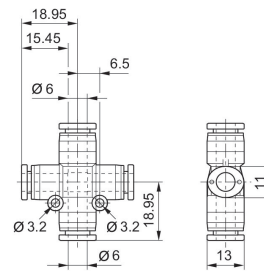

R412005363

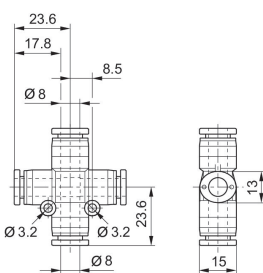

R412005364

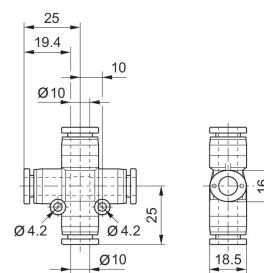



QR1-S-RED 标准系列

快插直接头，缩径  
快插接头  
针式衬套

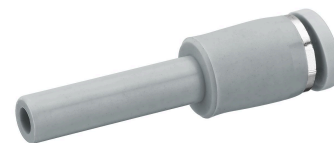

G	Ø D	供货数量 [件]	物料号
Ø 4	Ø 6	10	2121706040
Ø 4	Ø 8	10	2121708040
Ø 4	Ø 10	10	2121710040
Ø 6	Ø 8	10	2121708060
Ø 6	Ø 10	10	2121710060
Ø 6	Ø 12	10	2121712060
Ø 8	Ø 10	10	2121710080
Ø 8	Ø 12	10	2121712080
Ø 8	Ø 14	10	2121714080
Ø 10	Ø 12	10	2121712100
Ø 10	Ø 14	10	2121714100
Ø 12	Ø 14	10	2121714120

2121706040

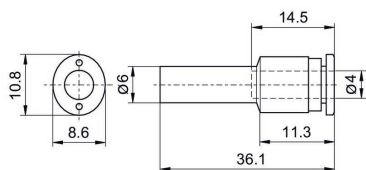

2121708040

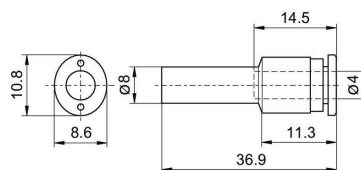

2121710040

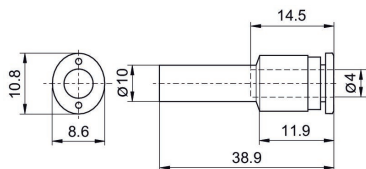

2121708060

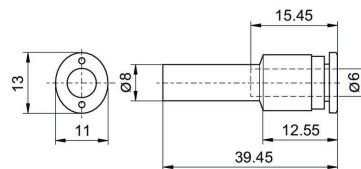

2121710060

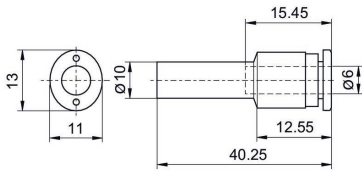

2121712060

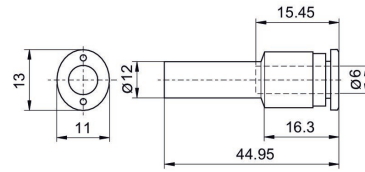

2121710080

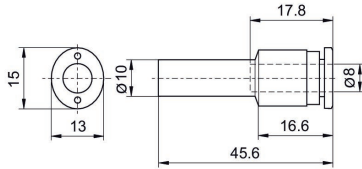

2121712080

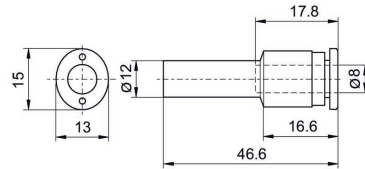

2121714080

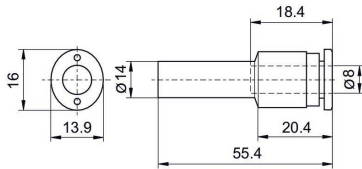

2121712100

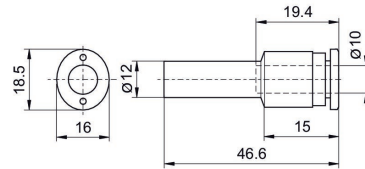

2121714100

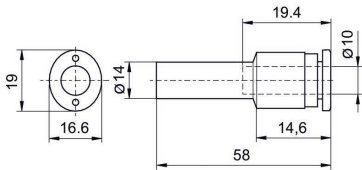

2121714120

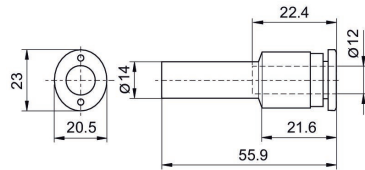

QR1-S-RVA 标准系列

弯角连接插口  
针式衬套  
快插接头

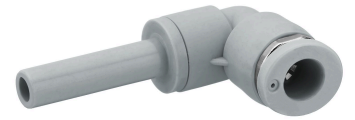

G	Ø D	供货数量 [件]	物料号
Ø 4	Ø 4	10	2121304040
Ø 6	Ø 6	10	2121306060
Ø 8	Ø 8	10	2121308080
Ø 10	Ø 10	10	2121310100
Ø 12	Ø 12	10	R412005036

2121304040

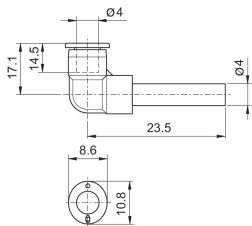

2121306060

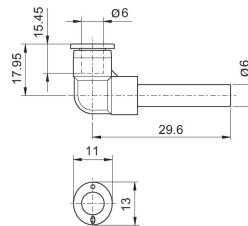

2121308080

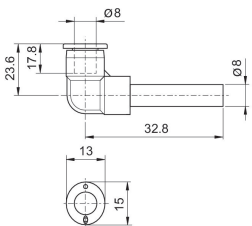

2121310100

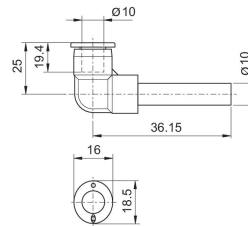

R412005036

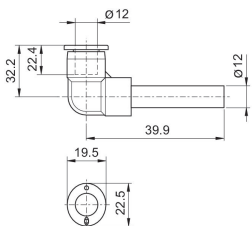

QR1-S-RLL 标准系列

弯角连接插口  
长针式衬套  
快插接头

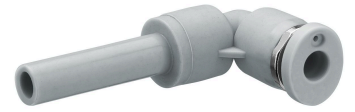

G	Ø D	供货数量 [件]	物料号
Ø 4	Ø 4	10	R412005039
Ø 6	Ø 6	10	R412005040
Ø 8	Ø 8	10	R412005041
Ø 10	Ø 10	10	R412005042
Ø 12	Ø 12	10	R412005043

R412005039

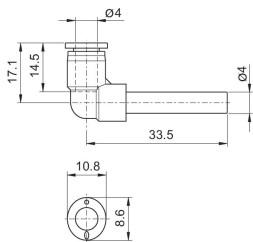

R412005040

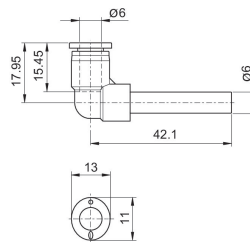

R412005041

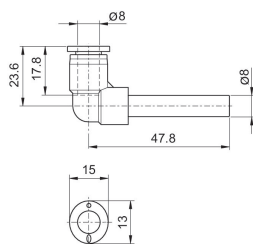

R412005042

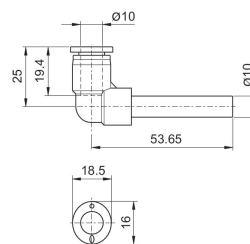

R412005043

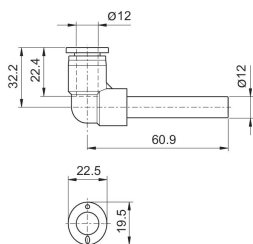

QR1-S-RVR 标准系列

弯角连接插口  
快插接头，减径  
针式衬套



G	Ø D	供货数量 [件]	物料号
Ø 4	Ø 6	10	2121304060
Ø 6	Ø 8	10	2121306080
Ø 8	Ø 10	10	R412005034

2121304060

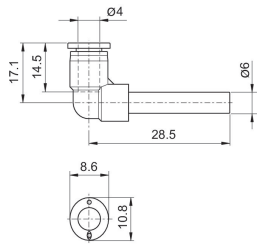

2121306080

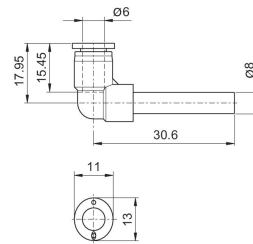

R412005034

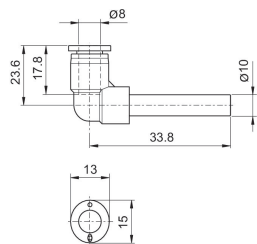

QR1-S-RTC 标准系列

T-快插接头  
针式衬套  
快插接头

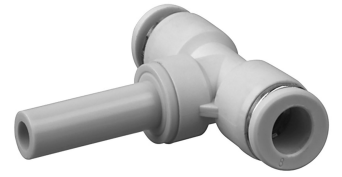

G	Ø D	供货数量 [件]	物料号
Ø 6	Ø 6	10	2122706000
Ø 8	Ø 8	10	2122708000
Ø 12	Ø 12	10	R412010596

2122706000

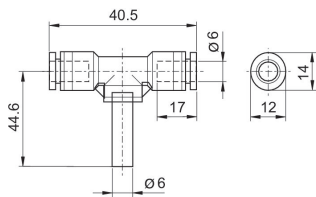

2122708000

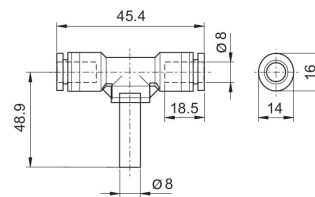

R412010596

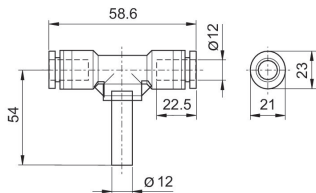

QR1-S-RY2 标准系列

Y-快插接头  
针式衬套  
快插接头

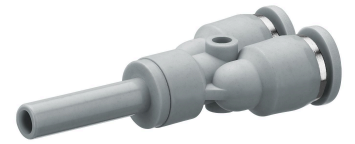

G	Ø D	供货数量 [件]	物料号
Ø 4	Ø 4	10	R412005332
Ø 6	Ø 6	10	R412005333
Ø 8	Ø 8	10	R412005334
Ø 10	Ø 10	10	R412005335
Ø 12	Ø 12	10	R412005336

R412005332

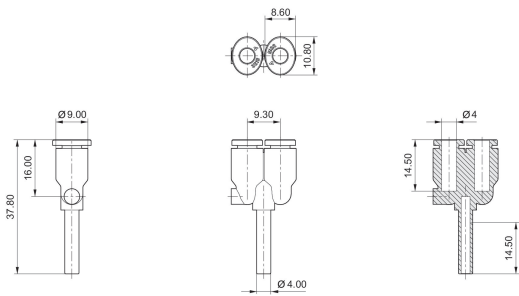

R412005333

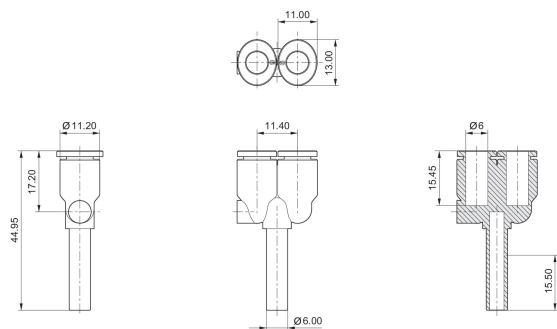

R412005334

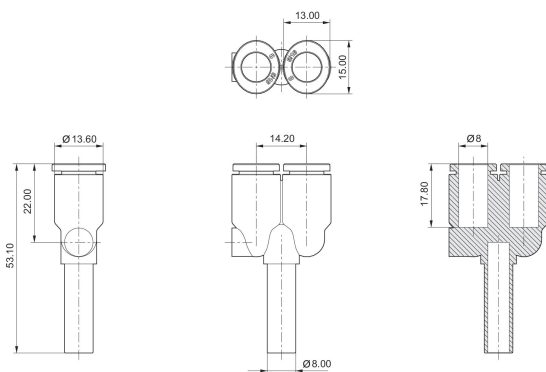

R412005335

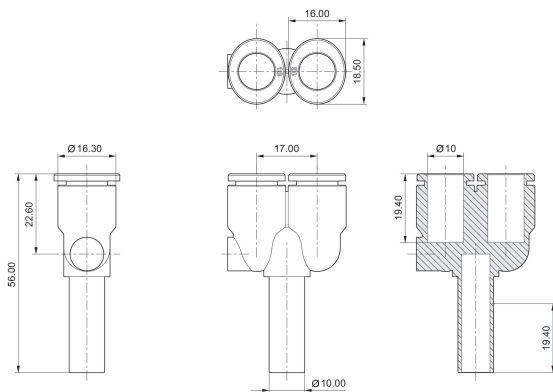

R412005336

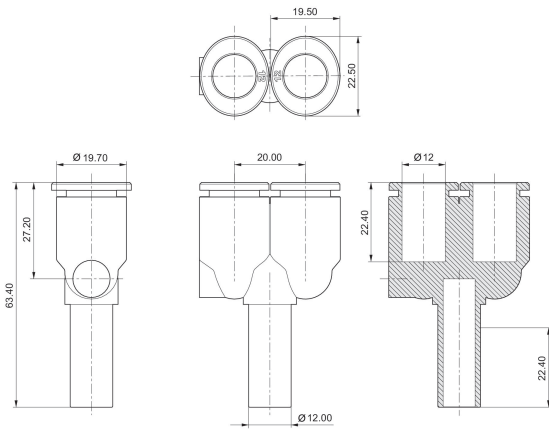



QR1-S-R2R 标准系列

Y型快插接头,减径  
快插接头  
针式衬套

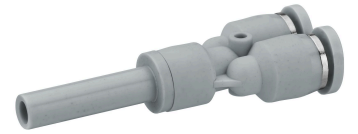

G	Ø D	供货数量 [件]	物料号
Ø 4	Ø 6	10	R412005337
Ø 6	Ø 8	10	R412005338
Ø 8	Ø 10	10	R412005339
Ø 10	Ø 12	10	R412005340

R412005337

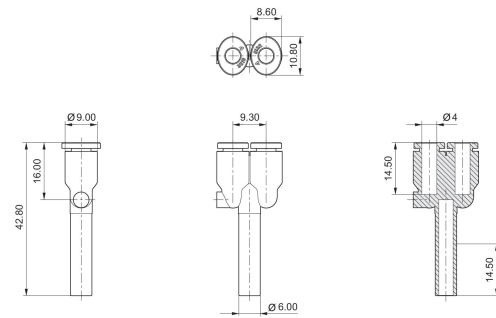

R412005338

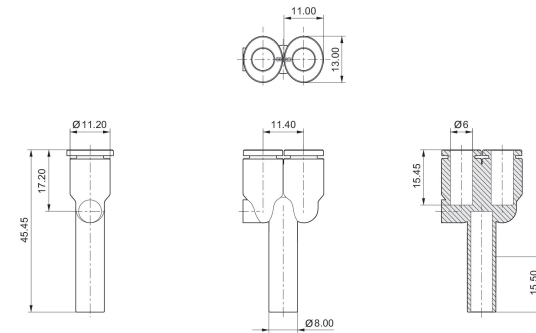

R412005339

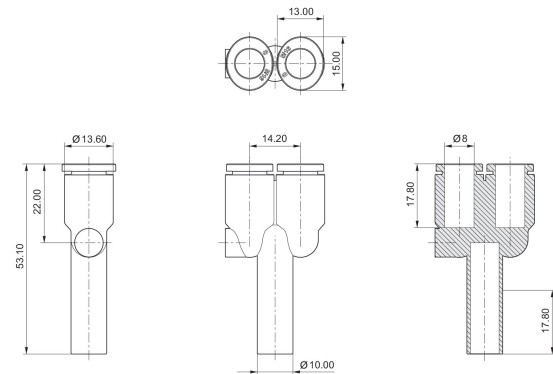

R412005340

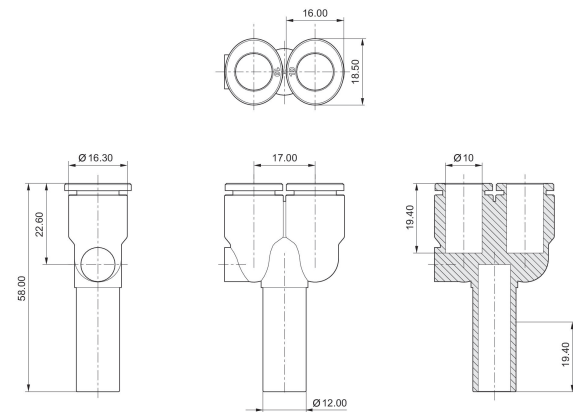

QR1-S-RY4 标准系列

Y型快插接头,减径  
针式衬套  
快插接头

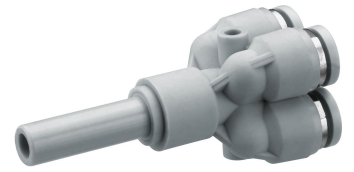

G	Ø D	供货数量 [件]	物料号
Ø 4	Ø 6	10	R412005341
Ø 4	Ø 8	10	R412005342

R412005341

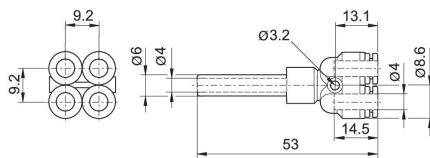

R412005342

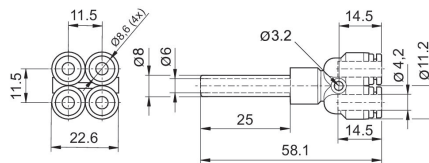

QR1-S-RCA 标准系列

密封盖  
快插接头



G	供货数量 [件]	物料号
Ø 4	20	R412005111
Ø 6	20	R412005112
Ø 8	20	R412005113
Ø 10	20	R412005114
Ø 12	20	R412005115

R412005111

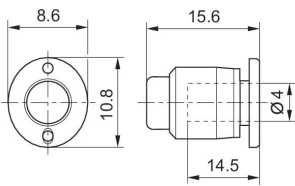

R412005112

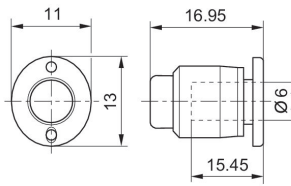

R412005113

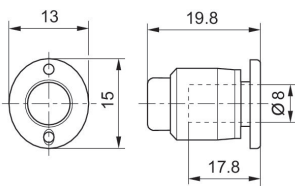

R412005114

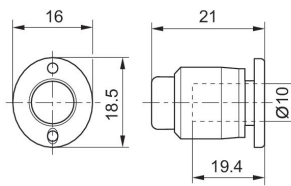

R412005115

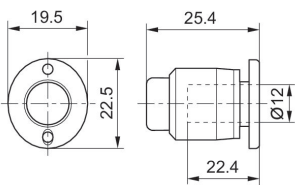

QR1-S-RBS 标准系列

堵头  
针式衬套



G	供货数量 [件]	物料号
Ø 4	20	2123204000
Ø 6	20	2123206000
Ø 8	20	2123208000
Ø 10	20	2123210000
Ø 12	20	2123212000
Ø 14	10	2123214000
Ø16	10	R412005331

规格

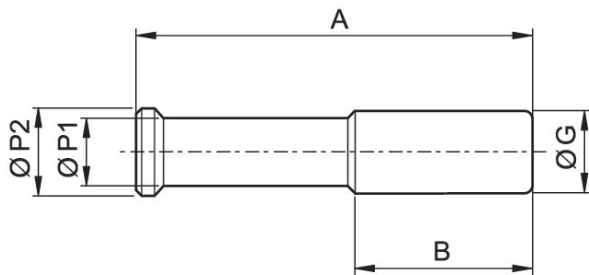

物料号	接口 G	A	B	Ø P1	Ø P2
2123204000		28	16	3	4
2123206000		32	17	4	6
2123208000		39	21,5	5	9
2123210000		42	21	8	10
2123212000		44	30	8	12
2123214000		45	24.6	8	14
R412005331		46	24.8	10	16

QR1-S-RDS 标准系列

连接块  
针式衬套  
针式衬套



G	Ø D	供货数量 [件]	物料号
Ø 4	Ø 4	10	2123104000
Ø 6	Ø 6	10	2123106000
Ø 8	Ø 8	10	2123108000
Ø 10	Ø 10	10	2123110000
Ø 12	Ø 12	10	2123112000

规格

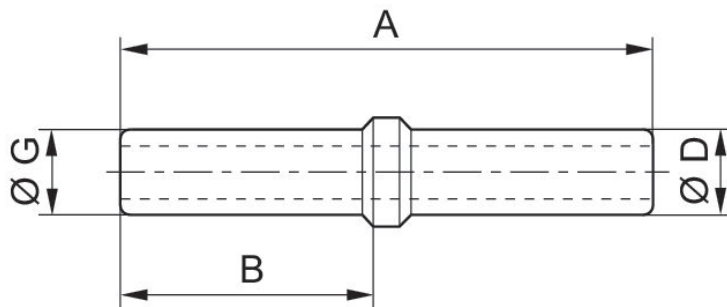

物料号	接口 D	接口 G	A	B
2123104000			37,5	17,8
2123106000			39,7	18,7
2123108000			43,4	20,7
2123110000			47,2	22,6
2123112000			53	25,5
2123114000			53	-
R412005322			54	24,8

QR1-S-RDR 标准系列

"减径连接件"  
针式衬套  
针式衬套

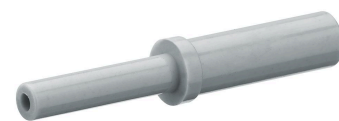

G	Ø D	供货数量 [件]	物料号
Ø 6	Ø 4	10	R412005323
Ø 8	Ø 4	10	R412005324
Ø 8	Ø 6	10	R412005325
Ø 10	Ø 6	10	R412005326
Ø 10	Ø 8	10	R412005327
Ø 12	Ø 8	10	R412005328
Ø 12	Ø 10	10	R412005329

R412005323

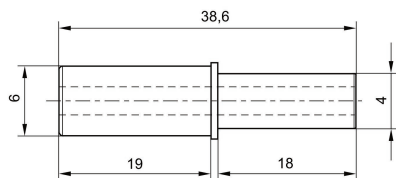

R412005324

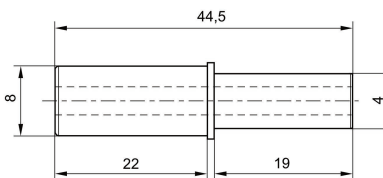

R412005325

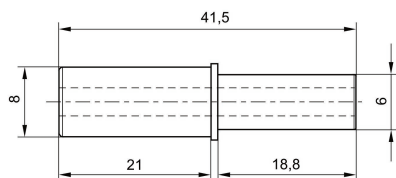

R412005326

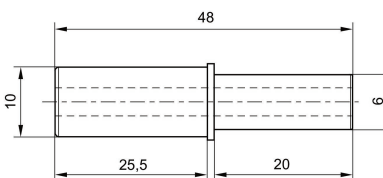

R412005327

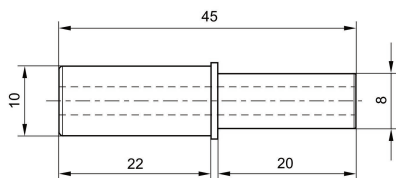

R412005328

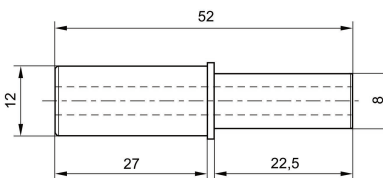

R412005329

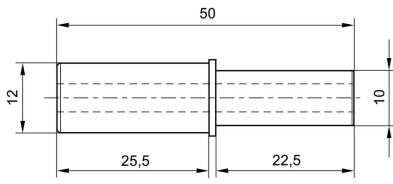

系列 QR1-S-M2R Mini

Y型快插接头,减径  
针式衬套  
快插接头

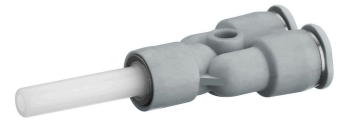

G	Ø D	供货数量 [件]	物料号
Ø 4	Ø 3	25	R412005445
Ø 6	Ø 4	25	R412005446

规格

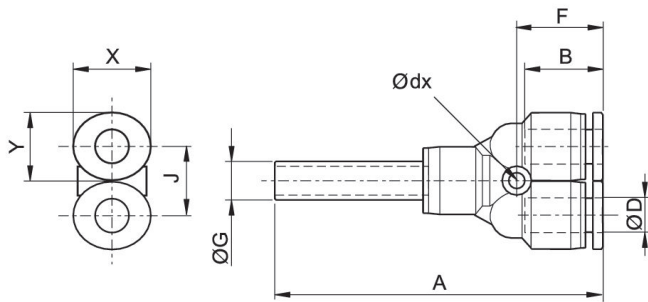

物料号	接口 D	接口 G	Ø dx	A	B	F	J	X	Y
R412005445	Ø 3	Ø 4	3.2	33	9.5	13.4	8	7	6
R412005446	Ø 4	Ø 6	3.2	38.5	11.5	13.6	10.5	10	8



系列 QR1-S-MAN Mini

带外六角直通管接头  
外螺纹  
快插接头



G		Ø D	供货数量 [件]	物料号
M3		Ø 3	25	R412005116
M3		Ø 4	25	R412005117
M5		Ø 3	25	R412005118
M5		Ø 4	25	R412005119
M5		Ø 6	25	R412005120
M6		Ø 3	25	R412005121
M6		Ø 4	25	R412005122
M6		Ø 6	25	R412005123
G 1/8		Ø 4	25	R412005124
G 1/8		Ø 6	25	R412005125

规格

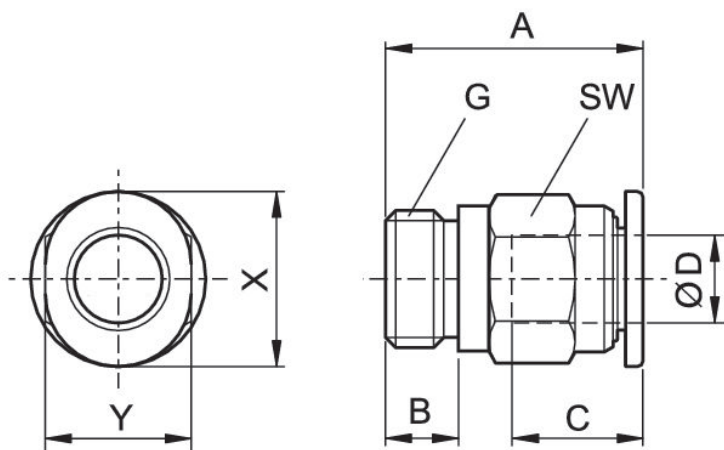

物料号	接口 D	接口 G	A	B	C	SW	X	Y
R412005116	Ø 3	M3	13.6	3	9.5	6	7	6
R412005117	Ø 4	M3	17.2	3	11.5	8	10	8
R412005118	Ø 3	M5	16.2	4	9.5	8	7	6
R412005119	Ø 4	M5	16.2	4	11.5	8	10	8

物料号	接口 D	接口 G	A	B	C	SW	X	Y
R412005120	Ø 6	M5	17.3	4 M3	12.5	10	12	10
R412005121	Ø 3	M6	17	5	9.5	8	7	6
R412005122	Ø 4	M6	17.4	5	11.5	8	10	8
R412005123	Ø 6	M6	18.3	5	12.5	10	12	10
R412005124	Ø 4	G 1/8	12.7	5	11.5	10	10	8
R412005125	Ø 6	G 1/8	14.9	5	12.5	10	12	10

系列 QR1-S-MBS Mini

堵头  
针式衬套



G	供货数量 [件]	物料号
Ø 3	25	R412005447

规格

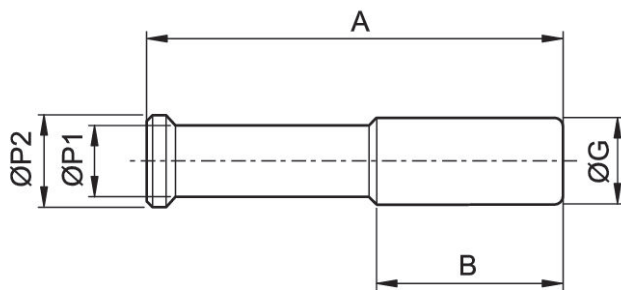

物料号	接口 G	A	B	Ø P1	Ø P2
R412005447	Ø 3	22	9.5	3	4

系列 QR1-S-MED Mini

快插直接头，缩径  
针式衬套  
快插接头



G	Ø D	供货数量 [件]	物料号
Ø 4	Ø 3	25	R412005437
Ø 6	Ø 4	25	R412005438

规格

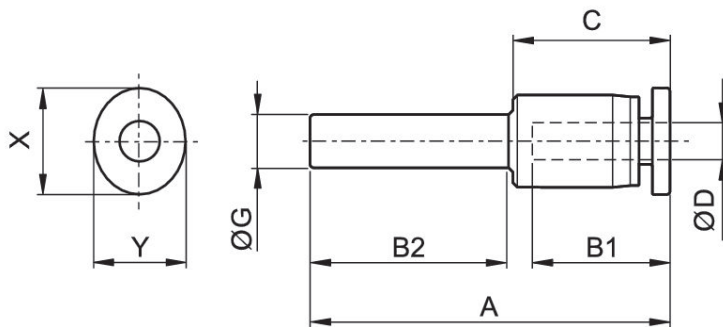

物料号	接口 D	接口 G	A	B1	B2	C	X	Y
R412005437	Ø 3	Ø 4	29.2	9.5	11.5	11.2	7	6
R412005438	Ø 4	Ø 6	33.2	11.5	12.5	13.2	10	8

系列 QR1-S-MIN Mini

带内六角直通管接头  
外螺纹  
快插接头



G		Ø D	供货数量 [件]	物料号
M3		Ø 3	25	R412005264
M3		Ø 4	25	R412005265
M5		Ø 3	25	R412005266
M5		Ø 4	25	R412005267
M5		Ø 6	25	R412005268
M6		Ø 3	25	R412005269
M6		Ø 4	25	R412005270
M6		Ø 6	25	R412005271
M7		Ø 4	25	R412005272
M7		Ø 6	25	R412005273
G 1/8		Ø 4	25	R412005274
G 1/8		Ø 6	25	R412005275

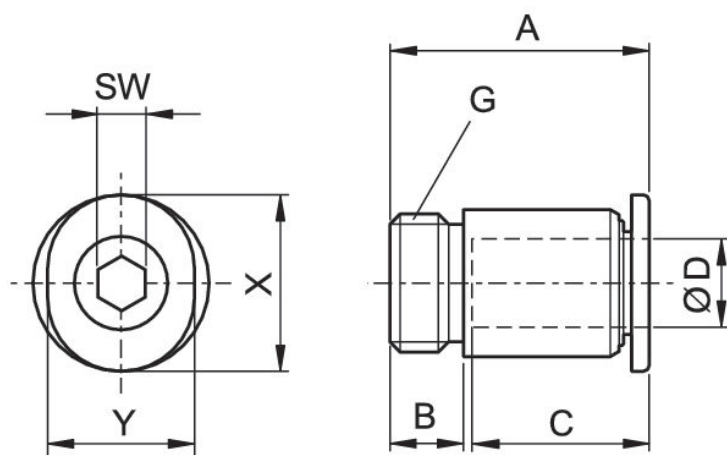

物料号	接口 D	接口 G	A	B	C	SW	X	Y
R412005264	Ø 3	M3	15.9	3	9.5	1.5	7	6
R412005265	Ø 4	M3	18	3	11.5	1.5	10	8
R412005266	Ø 3	M5	18	4	9.5	2	7	6

物料号	接口 D	接口 G	A	B	C	SW	X	Y
R412005267	Ø 4	M5	16.3	4	11.5	2.5	10	8
R412005268	Ø 6	M5	17.8	4	12.5	2.5	12	10
R412005269	Ø 3	M6	20.2	5	9.5	3	7	6
R412005270	Ø 4	M6	20.2	5	11.5	3	10	8
R412005271	Ø 6	M6	18.8	5	12.5	3	12	10
R412005272	Ø 4	M7	21.4	5	11.5	3	10	8
R412005273	Ø 6	M7	20.1	5	12.5	3	12	10
R412005274	Ø 4	G 1/8	17	5	11.5	3	10	8
R412005275	Ø 6	G 1/8	20.6	5	12.5	4	12	10

系列 QR1-S-MLT Mini

弯形螺纹管接头  
外螺纹  
快插接头

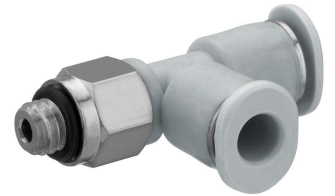

G	Ø D	供货数量 [件]	物料号
M5	Ø 4	25	R412005405
M5	Ø 6	25	R412005406
G 1/8	Ø 4	25	R412005410
G 1/8	Ø 6	25	R412005411

规格

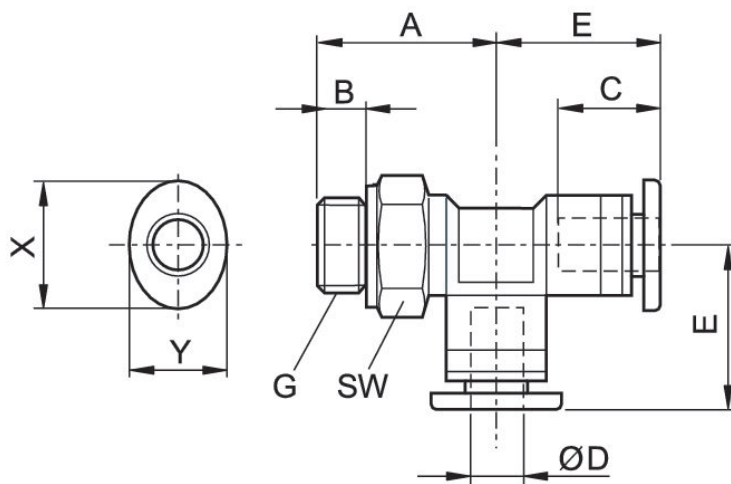

物料号	接口 D	接口 G	A	B	C	E	SW	X	Y
R412005405	Ø 4	M5	15	4	11.5	13.1	8	10	8
R412005406	Ø 6	M5	17	4	12.5	14.4	8	12	10
R412005410	Ø 4	G 1/8	13.4	5	11.5	13.1	10	10	8
R412005411	Ø 6	G 1/8	15	5	12.5	14.4	10	12	10

系列 QR1-S-MSK Mini

锁母式直接头  
快插接头  
快插接头

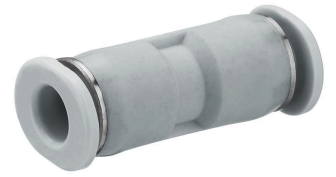

G	Ø D	供货数量 [件]	物料号
Ø 3	Ø 3	25	R412005412
Ø 4	Ø 4	25	R412005413
Ø 6	Ø 6	25	R412005414

规格

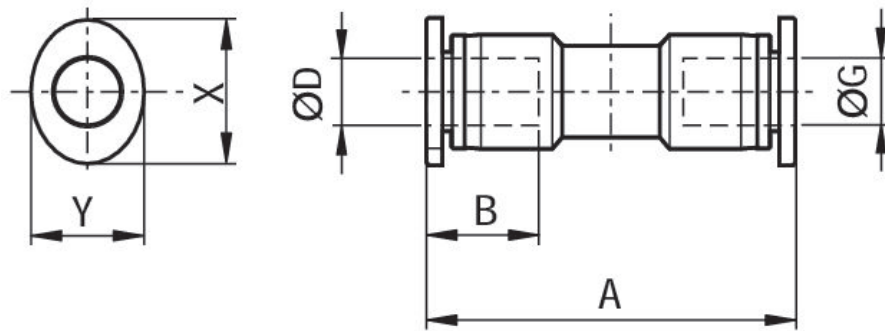

物料号	接口 D	接口 G	A	B	X	Y
R412005412	Ø 3	Ø 3	20.4	9.5	7	6
R412005413	Ø 4	Ø 4	23.8	11.5	10	8
R412005414	Ø 6	Ø 6	25.1	12.5	12	10



系列 QR1-S-MSM Mini

隔板插接接口，金属  
快插接头  
快插接头



G	Ø D	供货数量 [件]	物料号
Ø 4	Ø 4	25	R412005418
Ø 6	Ø 6	25	R412005419

规格

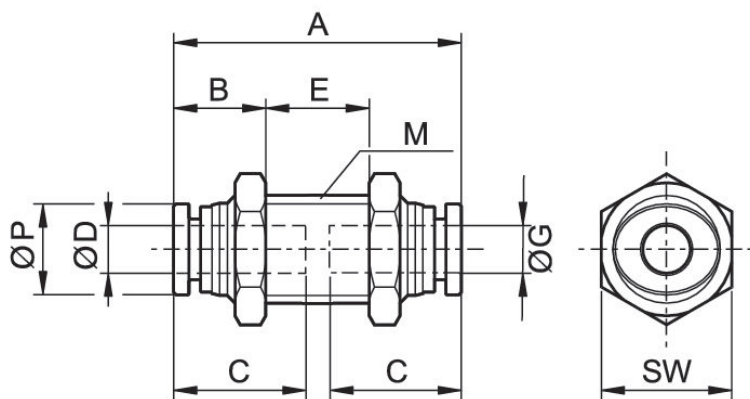

物料号	接口 D	接口 G	M	A	B	C	E	SW	Ø P
R412005418	Ø 4	Ø 4	M10x1,0	24	9	11.5	7.5	12	8
R412005419	Ø 6	Ø 6	M12x1,0	25.9	10.5	12.5	6	14	10.5

系列 QR1-S-MSR Mini

直接头, 缩径  
快插接头  
快插接头

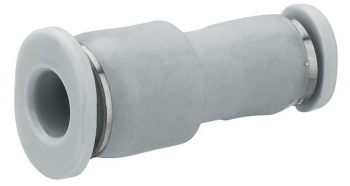

G	Ø D	供货数量 [件]	物料号
Ø 4	Ø 3	25	R412005415
Ø 6	Ø 4	25	R412005416

规格

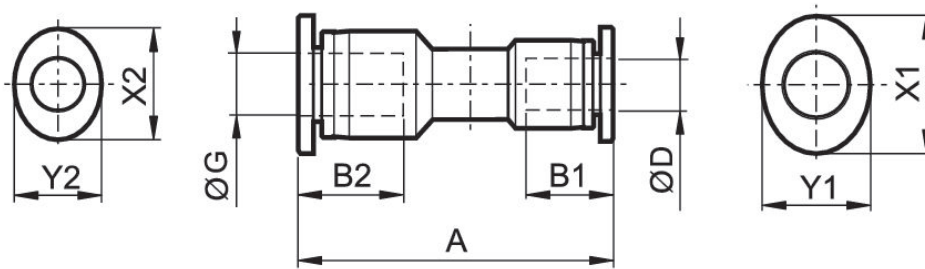

物料号	接口 D	接口 G	A	B1	B2	X1	X2	Y1	Y2
R412005415	Ø 3	Ø 4	22.5	9.5	11.5	7	10	6	8
R412005416	Ø 4	Ø 6	24	11.5	12.5	10	12	8	10

系列 QR1-S-MTK Mini

T-插塞连接  
快插接头  
快插接头

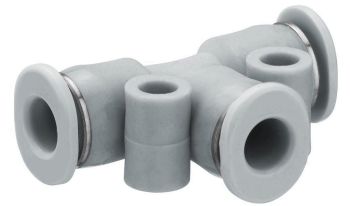

G	Ø D	供货数量 [件]	物料号
Ø 3	Ø 3	25	R412005426
Ø 4	Ø 4	25	R412005427
Ø 6	Ø 6	25	R412005428

规格

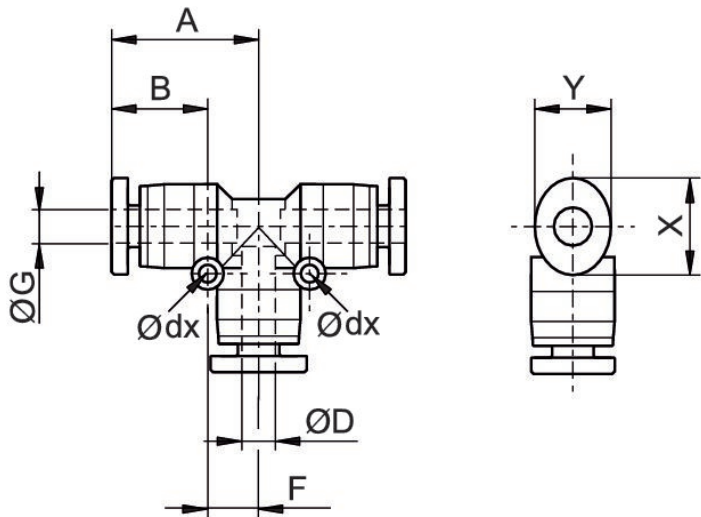

物料号	接口 D	接口 G	Ø dx	A	B	F	X	Y
R412005426	Ø 3	Ø 3	3.2	11.4	9.5	4.5	7	6
R412005427	Ø 4	Ø 4	3.2	13.9	11.5	5.8	10	8
R412005428	Ø 6	Ø 6	3.2	15.4	12.5	6.5	12	10

系列 QR1-S-MTT Mini

T-接头  
外螺纹  
快插接头

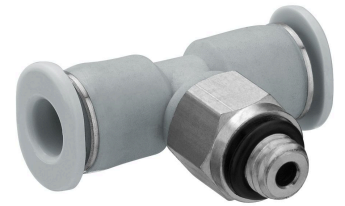

G	Ø D	供货数量 [件]	物料号
M5	Ø 4	25	R412005395
M5	Ø 6	25	R412005396
G 1/8	Ø 4	25	R412005400
G 1/8	Ø 6	25	R412005401

规格

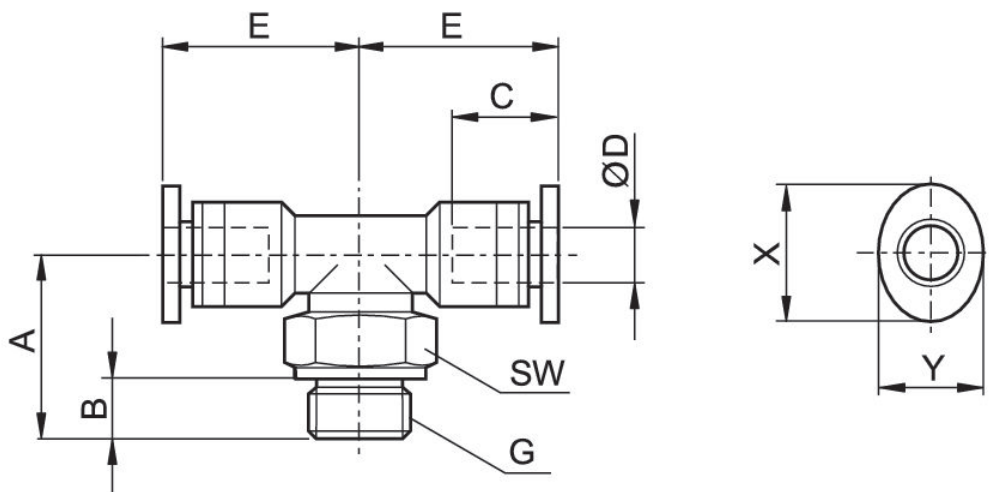

物料号	接口 D	接口 G	A	B	C	E	SW	X	Y
R412005395	Ø 4 M5 M5	M5	15	4	11.5	13.1	8	10	8
R412005396	Ø 6	M5	16	4	12.5	14.4	8	12	10
R412005400	Ø 4	G 1/8	13.4	5	11.5	13.1	12	10	8
R412005401	Ø 6	G 1/8	14.4	5	12.5	14.4	10	12	10

系列 QR1-S-MVA Mini

弯角连接插口  
针式衬套  
快插接头



G	Ø D	供货数量 [件]	物料号
Ø 3	Ø 3	25	R412005439
Ø 4	Ø 4	25	R412005440
Ø 6	Ø 6	25	R412005441

规格

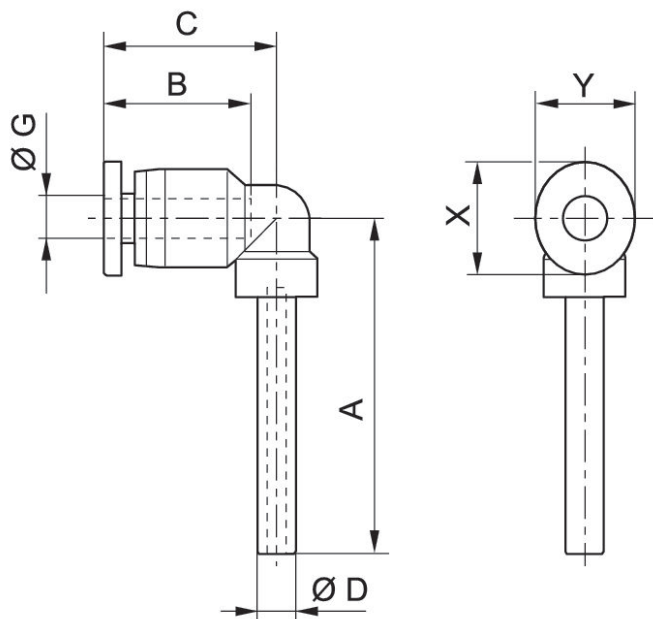

物料号	接口 D	接口 G	A	B	C	X	Y
R412005439	Ø 3	Ø 3	21.6	9.5	11.2	7	6
R412005440	Ø 4	Ø 4	27.6	11.5	15.6	10	8
R412005441	Ø 6	Ø 6	29.6	12.5	16.9	12	10

系列 QR1-S-MVK Mini

弯角插头连接器  
快插接头  
快插接头

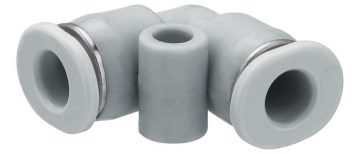

G	Ø D	供货数量 [件]	物料号
Ø 3	Ø 3	25	R412005423
Ø 4	Ø 4	25	R412005424
Ø 6	Ø 6	25	R412005425

规格

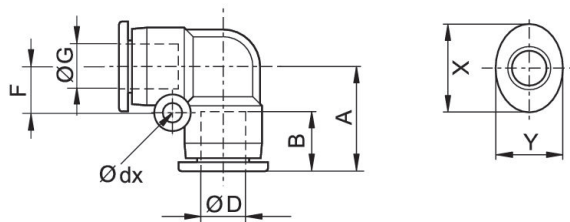

物料号	接口 D	接口 G	Ø dx	A	B	F	X	Y
R412005423	Ø 3	Ø 3	3.2	11.4	9.5	4.5	7	6
R412005424	Ø 4	Ø 4	3.2	13.9	11.5	5.8	10	8
R412005425	Ø 6	Ø 6	3.2	15.4	12.5	6.5	12	10

系列 QR1-S-MVL Mini

长弯头  
外螺纹  
快插接头



G	Ø D	供货数量 [件]	物料号
M3	Ø 3	25	R412005381
M3	Ø 4	25	R412005382
M5	Ø 4	25	R412005384
M5	Ø 6	25	R412005385
G 1/8	Ø 4	25	R412005390
G 1/8	Ø 6	25	R412005391

规格

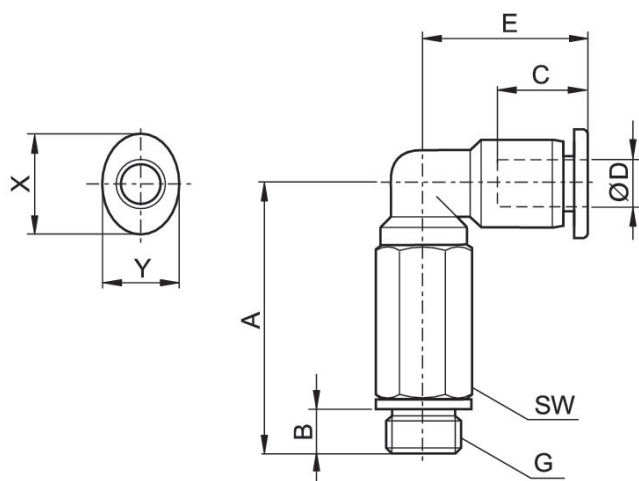

物料号	接口 D	接口 G	A	B	C	E	SW	X	Y
R412005381	Ø 3	M3	19.4	3	9.5	11.2	6	7	6
R412005382	Ø 4	M3	23	3	11.5	15.6	8	10	8
R412005384	Ø 4	M5	26	4	11.5	15.6	8	10	8
R412005385	Ø 6	M5	26	4	12.5	16.9	8	12	10
R412005390	Ø 4	G 1/8	25.1	5	11.5	15.6	10	10	8
R412005391	Ø 6	G 1/8	26.4	5	12.5	16.9	10	12	10

系列 QR1-S-MVS Mini

弯角隔壁接头  
快插接头  
快插接头



G	Ø D	供货数量 [件]	物料号
Ø 4	Ø 4	25	R412005421
Ø 6	Ø 6	25	R412005422

规格

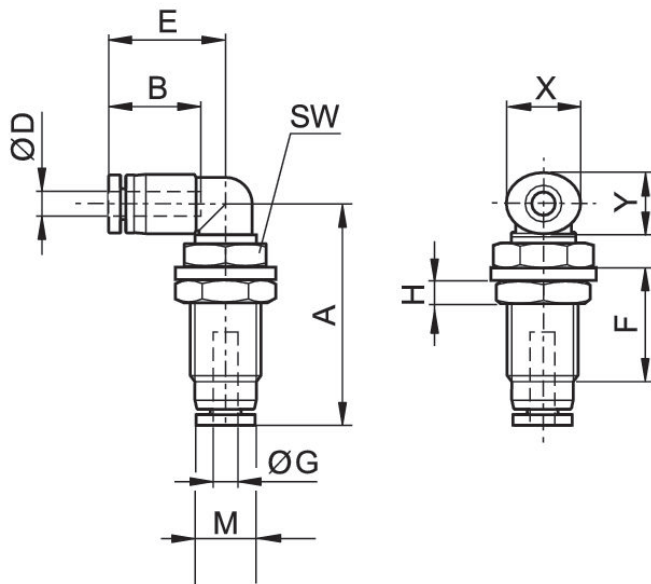

物料号	接口 D	接口 G	M	A	B	E	F	H	SW	X
R412005421	Ø 4	Ø 4	M10x1,0	24.4	11.5	15.3	13	3	12	10
R412005422	Ø 6	Ø 6	M12x1,0	31.5	12.5	16.3	16.6	4	14	12

物料号	Y
R412005421	8
R412005422	10



系列 QR1-S-MVT Mini

弯头  
外螺纹  
快插接头

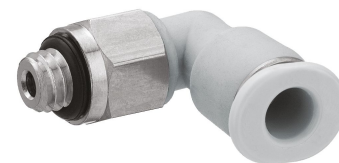

G		Ø D	供货数量 [件]	物料号
M3		Ø 3	25	R412005284
M3		Ø 4	25	R412005285
M5		Ø 3	25	R412005286
M5		Ø 4	25	R412005287
M5		Ø 6	25	R412005288
M6		Ø 3	25	R412005289
M6		Ø 6	25	R412005627
M6		Ø 4	25	R412005628
M7		Ø 4	25	R412005377
M7		Ø 6	25	R412005378
G 1/8		Ø 4	25	R412005379
G 1/8		Ø 6	25	R412005380

规格

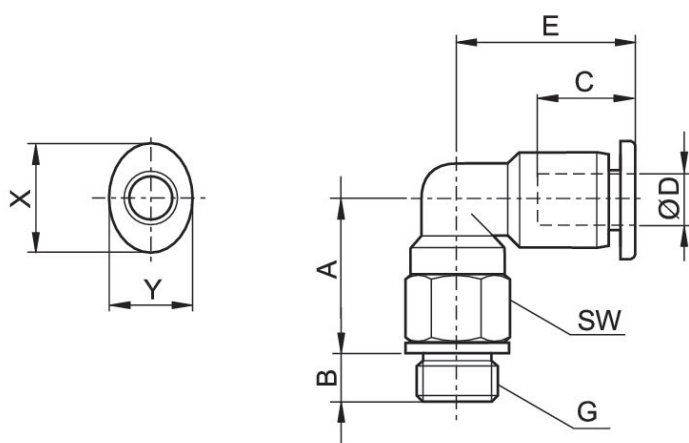

物料号	接口 D	接口 G	A	B	C	E	SW	X	Y
R412005284	Ø 3	M3	10.4	3	9.5	11.2	6	7	6
R412005285	Ø 4	M3	12	3	11.5	15.6	8	10	8
R412005286	Ø 3	M5	11.3	3.5	9.5	11.2	8	7	6

物料号	接口 D	接口 G	A	B	C	E	SW	X	Y
R412005287	Ø 4	M5	11.6	3.5	11.5	15.6	8	10	8
R412005288	Ø 6	M5	12.9	3.5	12.5	16.9	8	12	10
R412005289	Ø 3	M6	11.9	4.5	9.5	11.2	8	7	6
R412005628	Ø 4	M6	11.6	4.5	12.5	15.6	8	12	10
R412005627	Ø 6	M6	12.9	4.5	11.5	16.9	10	10	8
R412005377	Ø 4	M7	13.7	5.5	11.5	15.6	8	10	8
R412005378	Ø 6	M7	15	5.5	12.5	16.9	8	12	10
R412005379	Ø 4	G 1/8	12.6	5	11.5	15.6	12	10	8
R412005380	Ø 6	G 1/8	17	5	12.5	16.9	10	12	10

系列 QR1-S-MXS Mini

X-插头  
快插接头  
快插接头



G	Ø D	供货数量 [件]	物料号
Ø 4	Ø 4	25	R412005435
Ø 6	Ø 6	25	R412005436

规格

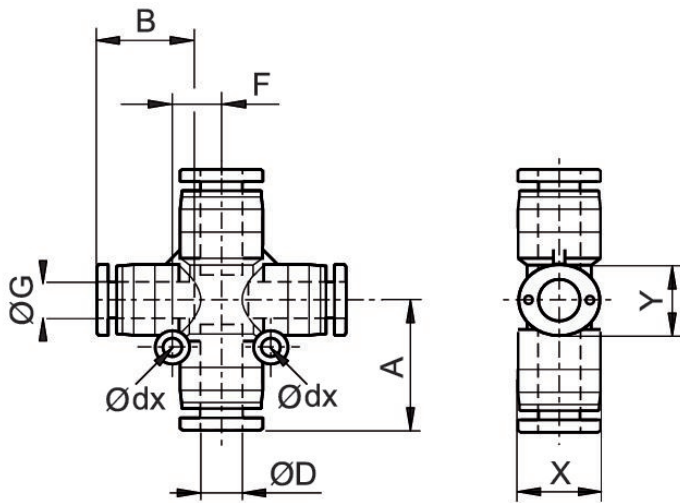

物料号	接口 D	接口 G	Ø dx	A	B	F	X	Y
R412005435	Ø 4	Ø 4	3.2	13.6	11.5	5.5	10	8
R412005436	Ø 6	Ø 6	3.2	15.9	12.5	6.5	12	10

系列 QR1-S-MYK Mini

Y-插头  
快插接头  
快插接头

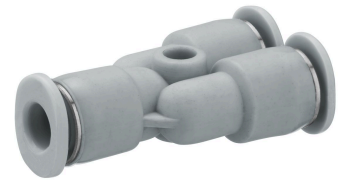

G	Ø D	供货数量 [件]	物料号
Ø 3	Ø 3	25	R412005429
Ø 4	Ø 4	25	R412005430
Ø 6	Ø 6	25	R412005431

规格

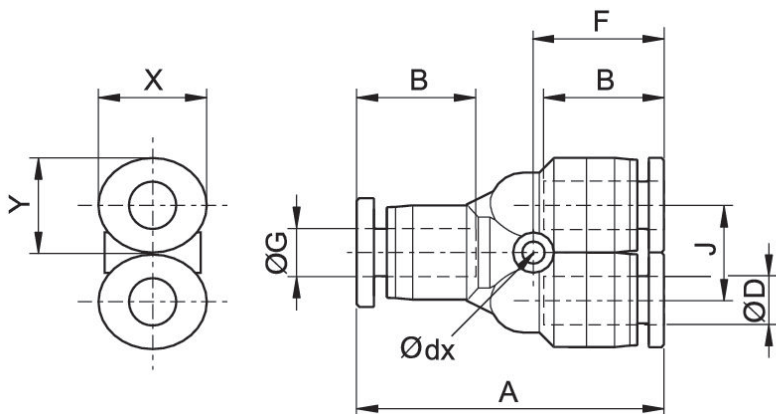

物料号	接口 D	接口 G	Ø dx	A	B	F	J	X	Y
R412005429	Ø 3	Ø 3	3.2	29.9	9.5	13.2	8	7	6
R412005430	Ø 4	Ø 4	3.2	30.1	11.5	13.3	8	10	8
R412005431	Ø 6	Ø 6	3.2	32.1	12.5	13.6	10.5	12	10

系列 QR1-S-MYR Mini

Y型快插接头，减径  
快插接头  
快插接头

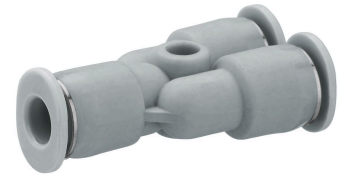

G	Ø D	供货数量 [件]	物料号
Ø 4	Ø 3	25	R412005432
Ø 6	Ø 4	25	R412005433

规格

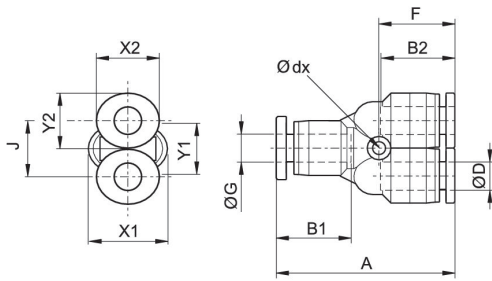

物料号	接口 D	接口 G	Ø dx	A	B1	B2	F	J	X1	X2
R412005432	Ø 3	Ø 4	3.2	30	11.5	9.5	13.4	8	10	7
R412005433	Ø 4	Ø 6	3.2	31.5	12.5	11.5	13.6	10.5	12	10

物料号	Y1	Y2
R412005432	8	6
R412005433	10	8

系列 QR1-S-MYZ Mini

Y-快插接头  
针式衬套  
快插接头



G	Ø D	供货数量 [件]	物料号
Ø 4	Ø 4	25	R412005443
Ø 6	Ø 6	25	R412005444

规格

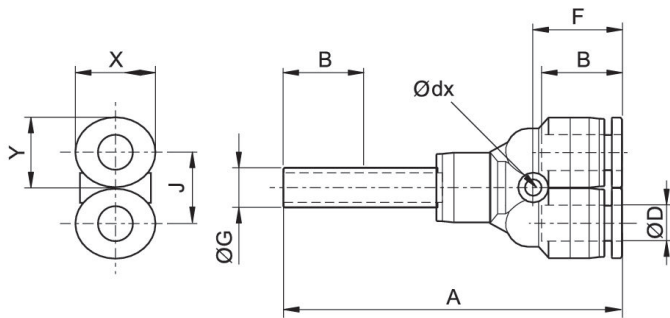

物料号	接口 D	接口 G	Ø dx	A	B	F	J	X	Y
R412005443	Ø 4	Ø 4	3.2	45	11.5	13.3	8	10	8
R412005444	Ø 6	Ø 6	3.2	50.5	12.5	13.6	10.4	12	10

# Efficient pneumatic solutions, our program: cylinders and drives, valves and valve systems, air supply management



Visit us: [Emerson.com/Aventics](https://www.emerson.com/Aventics)

Your local contact: [Emerson.com/contactus](https://www.emerson.com/contactus)



[Emerson.com](https://www.emerson.com)



[Facebook.com/EmersonAutomationSolutions](https://www.facebook.com/EmersonAutomationSolutions)



[LinkedIn.com/company/Emerson-Automation-Solutions](https://www.linkedin.com/company/Emerson-Automation-Solutions)



[Twitter.com/EMR\\_Automation](https://twitter.com/EMR_Automation)

An example configuration is depicted on the title page. The delivered product may thus vary from that in the illustration. Subject to change. This Document, as well as the data, specifications and other information set forth in it, are the exclusive property of AVENTICS GmbH. It may not be reproduced or given to third parties without its consent. Only use the AVENTICS products shown in industrial applications. Read the product documentation completely and carefully before using the product. Observe the applicable regulations and laws of the respective country. When integrating the product into applications, note the system manufacturer's specifications for safe use of the product. The data specified only serve to describe the product. No statements concerning a certain condition or suitability for a certain application can be derived from our information. The information given does not release the user from the obligation of own judgment and verification. It must be remembered that the products are subject to a natural process of wear and aging.

The Emerson logo is a trademark and service mark of Emerson Electric Co. Brand logotype are registered trademarks of one of the Emerson family of companies. All other marks are the property of their respective owners. © 2019 Emerson Electric Co. All rights reserved.



**CONSIDER IT SOLVED™**