

Series SA1



Series SA1

The AVENTICS Series SA1 industrial shock absorbers decelerate reliably moving masses and thereby increase process speed, production quality, the service life of production facilities and reduce operating noise.

- Wide product range
- High energy absorption and extended life time
- Improved surface protection against corrosion
- Integrated end stop



Industrial shock absorber, Series SA1-MA



Mounting thread	Stroke [mm]	Max. energy absorption/stroke [Nm]	Max. energy absorption/hour [Nm]	Effective mass m_e min. [kg]	Effective mass m_e max. [kg]	Min. return spring force [N]	Max. return spring force [N]	Min. impact speed [m/s]	Max. impact speed [m/s]	Part No.
M12x1	12	22	35200	9	800	2.5	7	0.2	3.5	R412010322

Dimensions

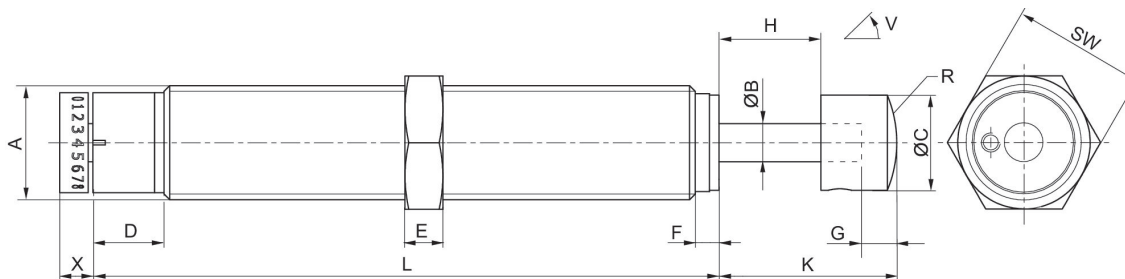

A = mounting thread
V = tilt

Part No.	Type	Mounting thread	$\varnothing B$	$\varnothing C$	D	E	F	G	H	K
R412010322	SA1-MA	M12x1	4	10	7.5	4	2.5	4	12	20

Part No.	L	R	SW	W [°]	X
R412010322	66	13	14	3	3.5

Industrial shock absorber, Series SA1-MA

RoHS
Conforms with REACH

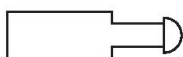

Mounting thread	Stroke [mm]	Max. energy absorption/stroke [Nm]	Max. energy absorption/hour [Nm]	Effective mass m_e min. [kg]	Effective mass m_e max. [kg]	Min. return spring force [N]	Max. return spring force [N]	Min. impact speed [m/s]	Max. impact speed [m/s]	Part No.
M14x1,5	14	30	50000	1.6	1500	13	23	0.1	6	R412010323
M20x1,5	19	100	76500	9	4500	12	23	0.1	6	R412010324
M25x1,5	25	220	105600	22	11000	15	31	0.1	6	R412010325
M27x2	25	220	105600	22	11000	15	31	0.1	6	R412028891
M25x1,5	40	390	175600	38	18000	11	20	0.1	6	R412010326
M27x2	40	390	175500	38	18000	11	20	0.1	6	R412028892

Dimensions

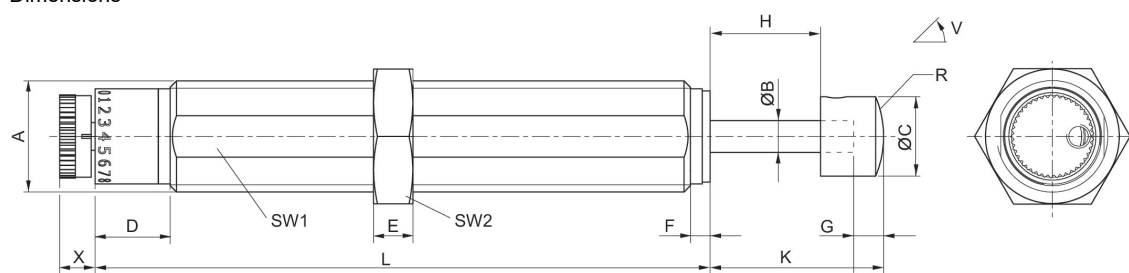

A = mounting thread
V = tilt

Part No.	Type	Mounting thread	ØB	ØC	D	E	F	G	H	K
R412010323	SA1-MA	M14x1,5	4	10	9.5	5	2.5	4	14	22
R412010324	SA1-MA	M20x1,5	6	16	10	6	2.5	4	19	29
R412010325	SA1-MA	M25x1,5	8	20	9	8	3.5	5	25	38
R412028891	SA1-MA	M27x2	8	20	9	8	3.5	5	25	38
R412010326	SA1-MA	M25x1,5	8	20	9	8	3.5	5	40	53
R412028892	SA1-MA	M27x2	8	20	9	8	3.5	5	40	53

Part No.	L	R	SW1	SW2	W [°]	X
R412010323	78	13	13	17	5	4.5
R412010324	88	32.5	18	24	2	5.7

Part No.	L	R	SW1	SW2	W [°]	X
R412010325	108	30.3	23	30	2	8.3
R412028891	108	30.3	24	30	2	8
R412010326	130	30.3	23	30	1	8
R412028892	130	30.3	24	30	1	8

Industrial shock absorber, Series SA1-MA

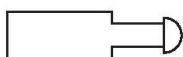

Mounting thread	Stroke [mm]	Max. energy absorption/stroke [Nm]	Max. energy absorption/hour [Nm]	Effective mass m_e min. [kg]	Effective mass m_e max. [kg]	Min. return spring force [N]	Max. return spring force [N]	Min. impact speed [m/s]	Max. impact speed [m/s]	Part No.
M33x1,5	25	300	120000	60	2950	30	50	0.02	6	R412010327
M33x1,5	50	500	150000	100	4000	23	50	0.02	6	R412010328
M42x3	50	500	150000	100	4000	23	50	0.02	6	R412028893
M42x3	75	700	210000	80	15000	15	100	0.02	6	R412028894
M64x2	100	5000	350000	1000	62500	45	130	0.02	6	R412010329
M64x2	150	8000	400000	1250	105000	35	130	0.02	6	R412010330

Dimensions

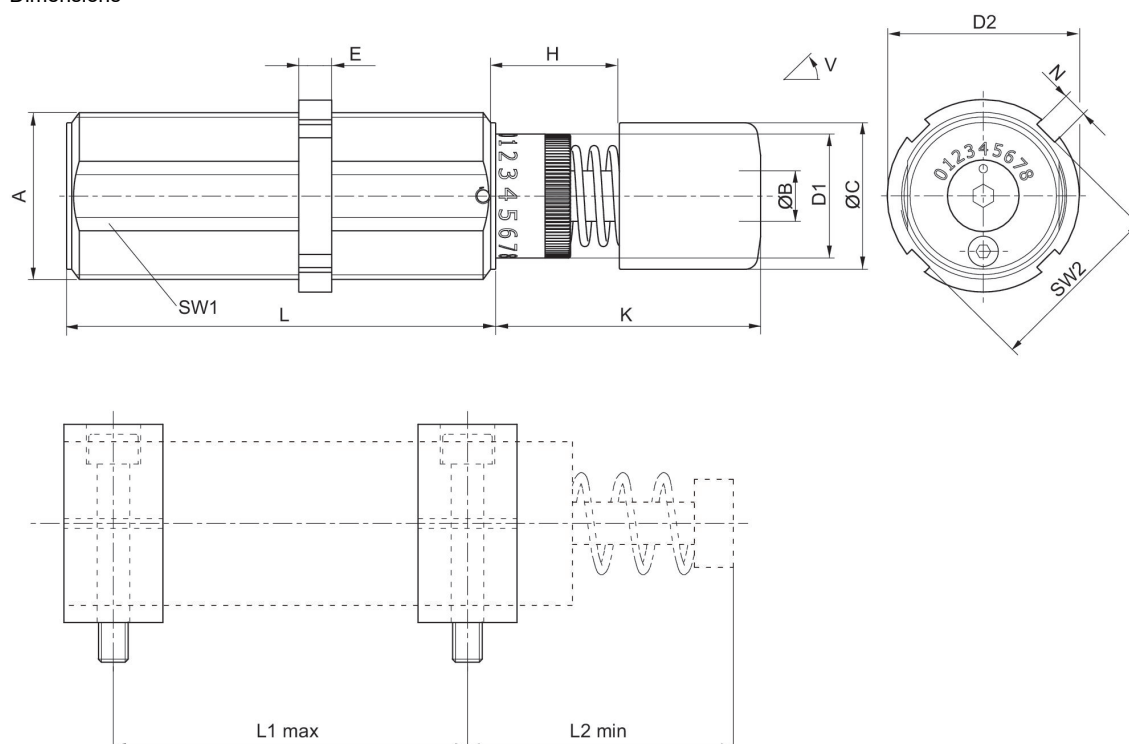

Positioning the clamping flanges
A = mounting thread
V = tilt

Part No.	Type	Mounting thread	L1 max	L2 min
R412010327	SA1-MA	M33x1,5	65	63
R412010328	SA1-MA	M33x1,5	90	88
R412010329	SA1-MA	M64x2	154	169,5
R412010330	SA1-MA	M64x2	221	219,5

You will find further dimensions on the catalog page for clamping flanges.

Part No.	Type	Mounting thread	ØB	ØC	ØD1	ØD2	E	H	K	L
R412010327	SA1-MA	M33x1,5	10	29	24.5	38	6.5	25	53	85
R412010328	SA1-MA	M33x1,5	10	29	24.5	38	6.5	50	78	110
R412028893	SA1-MA	M42x3	10	29	24.5	54	8	50	78	110
R412028894	SA1-MA	M42x3	10	29	24.5	54	8	75	103	140
R412010329	SA1-MA	M64x2	22	59	51	74	10	100	157	179
R412010330	SA1-MA	M64x2	22	59	51	74	10	150	207	246

Part No.	N	SW1	SW2	W [°]
R412010327	5	30	35	4
R412010328	5	30	35	3
R412028893	6	36	51	3
R412028894	6	51	54	2
R412010329	10	60	71	3
R412010330	10	60	71	2

Industrial shock absorber, Series SA1-MC

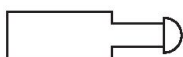

Mounting thread	Stroke [mm]	Max. energy absorption/stroke [Nm]	Max. energy absorption/hour [Nm]	Effective mass m_e min. [kg]	Effective mass m_e max. [kg]	Min. return spring force [N]	Max. return spring force [N]	Part No.
M6x0,5	5	1	3000	0.8	2.8	2	5	R412010284
M6x0,5	5	1	3000	1.5	4	2	5	R412010285

Dimensions

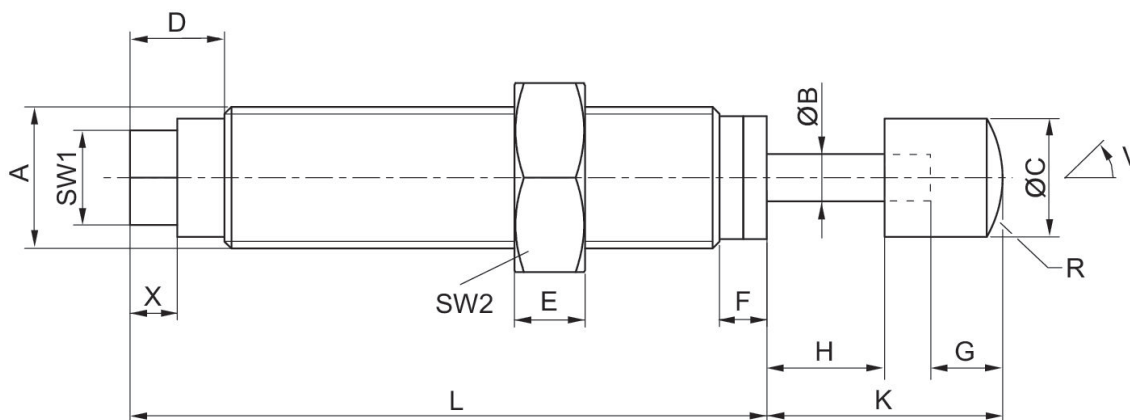

A = mounting thread
V = tilt

Part No.	Type	Mounting thread	ØB	ØC	D	E	F	G	H	K
R412010284	SA1-MC	M6x0,5	2	5	4	3	2	2	5	10
R412010285	SA1-MC	M6x0,5	2	5	4	3	2	2	5	10

Part No.	L	R	SW1	SW2	W [°]	X
R412010284	27	5	4	8	2	2
R412010285	27	5	4	8	2	2

Industrial shock absorber, Series SA1-MC

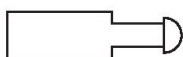

Mounting thread	Stroke [mm]	Max. energy absorption/stroke [Nm]	Max. energy absorption/hour [Nm]	Effective mass m_e min. [kg]	Effective mass m_e max. [kg]	Min. return spring force [N]	Max. return spring force [N]	Part No.
M8x1	5	1.5	4000	0.5	4	2	5	R412010286
M8x1	5	1.5	4000	0.8	6	2	5	R412010287

Dimensions

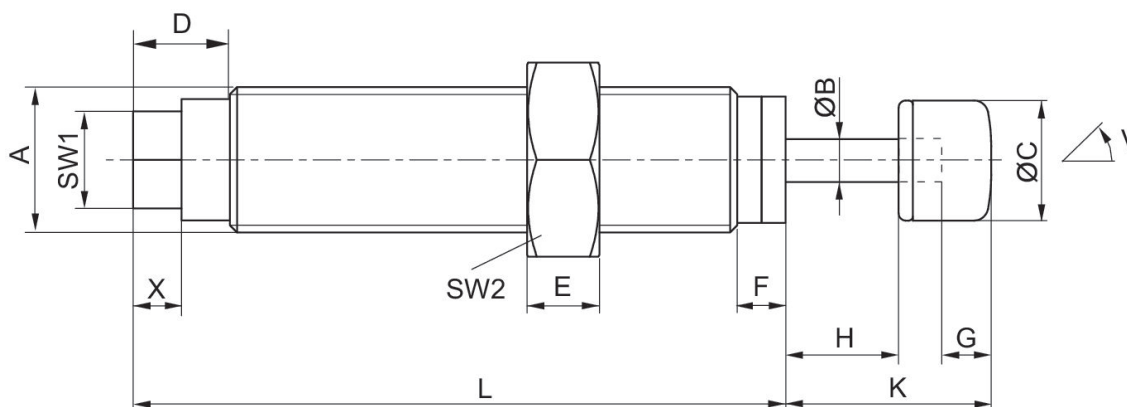

A = mounting thread
V = tilt

Part No.	Type	Mounting thread	ØB	ØC	D	E	F	G	H	K
R412010286	SA1-MC	M8x1	2.3	6.5	6	3	2.5	3	5	11.5
R412010287	SA1-MC	M8x1	2.3	6.5	6	3	2.5	3	5	11.5

Part No.	L	SW1	SW2	W [°]	X
R412010286	30	5.5	11	3	3
R412010287	30	5.5	11	3	3

Industrial shock absorber, Series SA1-MC



Mounting thread	Stroke [mm]	Max. energy absorption/stroke [Nm]	Max. energy absorption/hour [Nm]	Effective mass m_e min. [kg]	Effective mass m_e max. [kg]	Min. return spring force [N]	Max. return spring force [N]	Part No.
M10x1	8	10	24000	1.3	5.3	3.6	8	R412010288
M10x1	8	10	24000	4.3	20	3.6	8	R412010289
M10x1	8	10	24000	16.5	47	3.6	8	R412010290

Dimensions

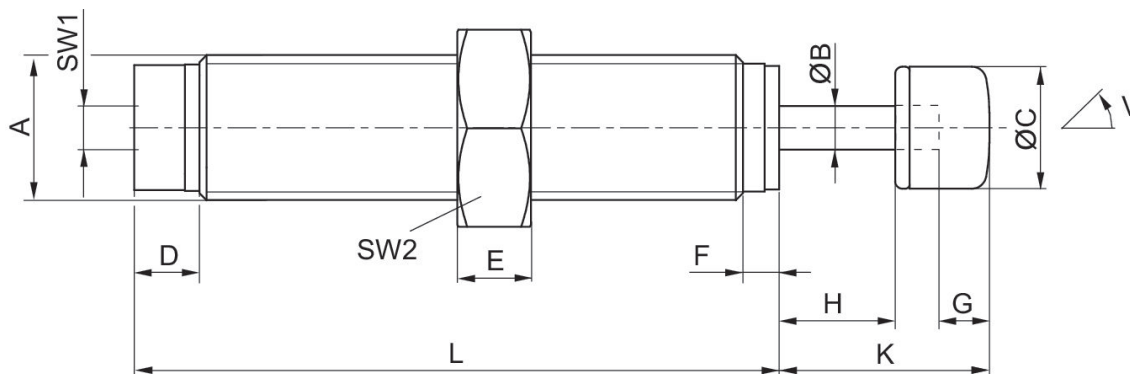

A = mounting thread
V = tilt

Part No.	Type	Mounting thread	ØB	ØC	D	E	F	G	H	K
R412010288	SA1-MC	M10x1	3	8.4	4.5	3	2.5	3	8	14.5
R412010289	SA1-MC	M10x1	3	8.4	4.5	3	2.5	3	8	14.5
R412010290	SA1-MC	M10x1	3	8.4	4.5	3	2.5	3	8	14.5

Part No.	L	SW1	SW2	W [°]
R412010288	44.5	3	13	2
R412010289	44.5	3	13	2
R412010290	44.5	3	13	2

Industrial shock absorber, Series SA1-MC



Mounting thread	Stroke [mm]	Max. energy absorption/stroke [Nm]	Max. energy absorption/hour [Nm]	Effective mass m_e min. [kg]	Effective mass m_e max. [kg]	Min. return spring force [N]	Max. return spring force [N]	Part No.
M12x1	10	14	30000	0.5	1.8	3.5	7	R412010291
M12x1	10	14	30000	1.5	7.7	3.5	7	R412010292
M12x1	10	14	30000	5	57	3.5	7	R412010293

Dimensions

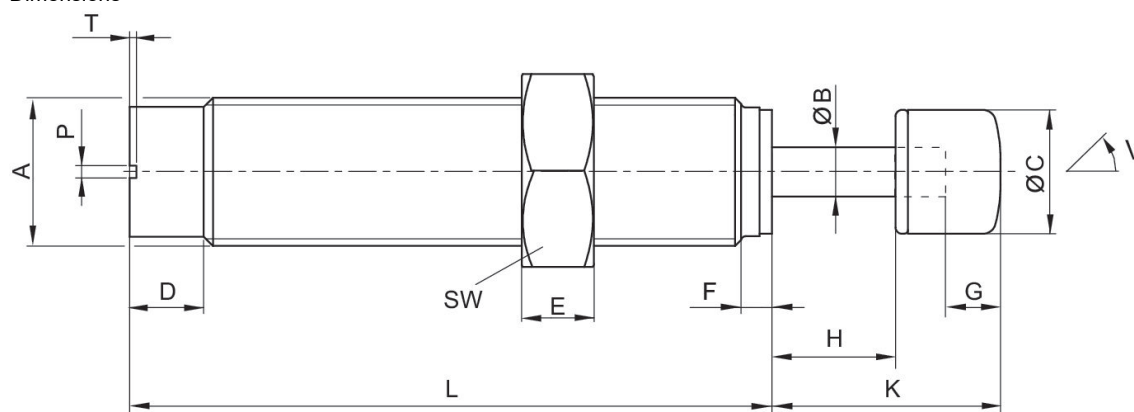

A = mounting thread
V = tilt

Part No.	Type	Mounting thread	ØB	ØC	D	E	F	G	H	K
R412010291	SA1-MC	M12x1	4	10	6	4	2.5	4	10	18.5
R412010292	SA1-MC	M12x1	4	10	6	4	2.5	4	10	18.5
R412010293	SA1-MC	M12x1	4	10	6	4	2.5	4	10	18.5

Part No.	L	P	T	SW	W [°]
R412010291	52	1	0.6	14	2
R412010292	52	1	0.6	14	2
R412010293	52	1	0.6	14	2

Industrial shock absorber, Series SA1-MC



Mounting thread	Stroke [mm]	Max. energy absorption/stroke [Nm]	Max. energy absorption/hour [Nm]	Effective mass m_e min. [kg]	Effective mass m_e max. [kg]	Min. return spring force [N]	Max. return spring force [N]	Part No.
M6x0,5	5	1	3000	0.8	2.8	2	5	R412010294
M6x0,5	5	1	3000	1.5	4	2	5	R412010295

Dimensions

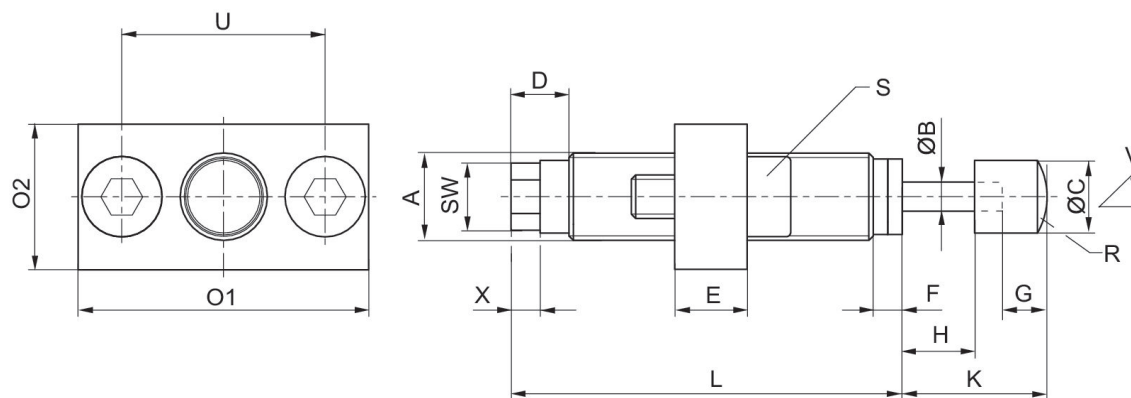

A = mounting thread
V = tilt

Part No.	Type	Mounting thread	ØB	ØC	D	E	F	G	H	K
R412010294	SA1-MC	M6x0,5	2	5	4	5	2	2	5	10
R412010295	SA1-MC	M6x0,5	2	5	4	5	2	2	5	10

Part No.	L	O1	O2	R	S	SW	U	W [°]	X
R412010294	27	20	10	5	M3x10	4	14	2	2
R412010295	27	20	10	5	M3x10	4	14	2	2

Industrial shock absorber, Series SA1-MC



Mounting thread	Stroke [mm]	Max. energy absorption/stroke [Nm]	Max. energy absorption/hour [Nm]	Effective mass m_e min. [kg]	Effective mass m_e max. [kg]	Min. return spring force [N]	Max. return spring force [N]	Part No.
M8x1	5	1.5	4000	0.5	4	2	5	R412010296
M8x1	5	1.5	4000	0.8	6	2	5	R412010297

Dimensions

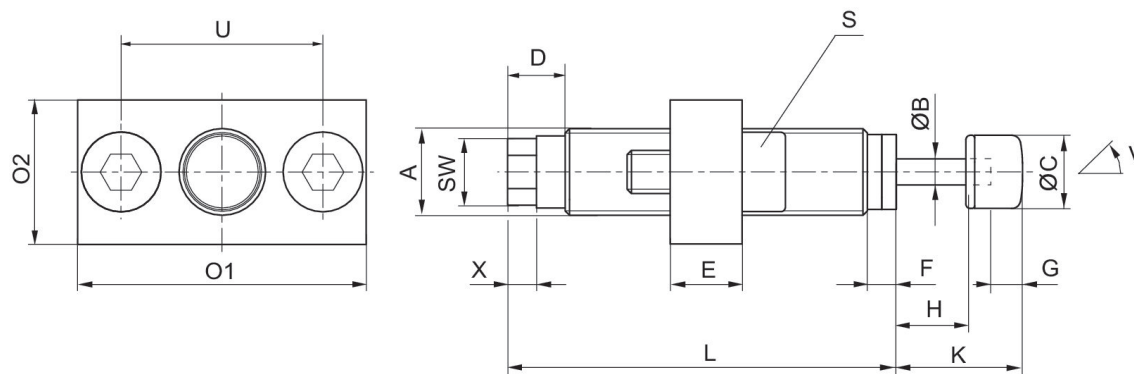

A = mounting thread
V = tilt

Part No.	Type	Mounting thread	ØB	ØC	D	E	F	G	H	K
R412010296	SA1-MC	M8x1	2.3	6.5	6	6	2.5	3	5	11.5
R412010297	SA1-MC	M8x1	2.3	6.5	6	6	2.5	5	5	11.5

Part No.	L	O1	O2	S	SW	U	W [°]	X
R412010296	30	25	15	M4x12	5.5	18	3	3
R412010297	30	25	15	M4x12	5.5	18	3	3

Industrial shock absorber, Series SA1-MC



Mounting thread	Stroke [mm]	Max. energy absorption/stroke [Nm]	Max. energy absorption/hour [Nm]	Effective mass m_e min. [kg]	Effective mass m_e max. [kg]	Min. return spring force [N]	Max. return spring force [N]	Part No.
M10x1	8	10	24000	1.3	5.3	3.6	8	R412010298
M10x1	8	10	24000	4.3	20	3.6	8	R412010299
M10x1	8	10	24000	16.5	47	3.6	8	R412010300

Dimensions

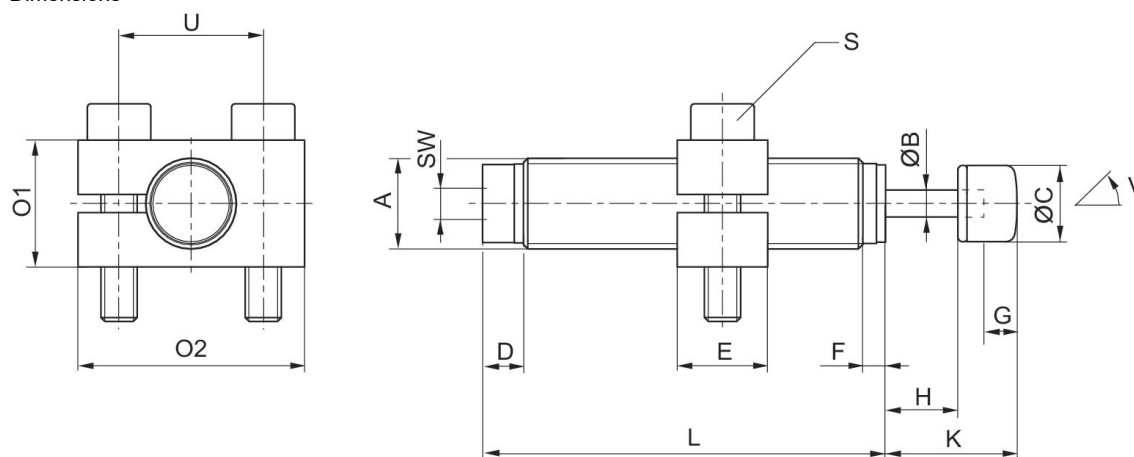

A = mounting thread
V = tilt

Part No.	Type	Mounting thread	$\varnothing B$	$\varnothing C$	D	E	F	G	H	K
R412010298	SA1-MC	M10x1	3	8.4	4.5	10	2.5	3	8	14.5
R412010299	SA1-MC	M10x1	3	8.4	4.5	10	2.5	3	8	14.5
R412010300	SA1-MC	M10x1	3	8.4	4.5	10	2.5	3	8	14.5

Part No.	L	O1	O2	S	SW	U	W [°]
R412010298	44.5	25	14	M4x20	3	16	2
R412010299	44.5	25	14	M4x20	3	16	2
R412010300	44.5	25	14	M4x20	3	16	2

Industrial shock absorber, Series SA1-MC



Mounting thread	Stroke [mm]	Max. energy absorption/stroke [Nm]	Max. energy absorption/hour [Nm]	Effective mass m_e min. [kg]	Effective mass m_e max. [kg]	Min. return spring force [N]	Max. return spring force [N]	Part No.
M12x1	10	14	30000	0.5	1.8	3.5	7	R412010301
M12x1	10	14	30000	1.5	7.7	3.5	7	R412010302
M12x1	10	14	30000	5	57	3.5	7	R412010303

Dimensions

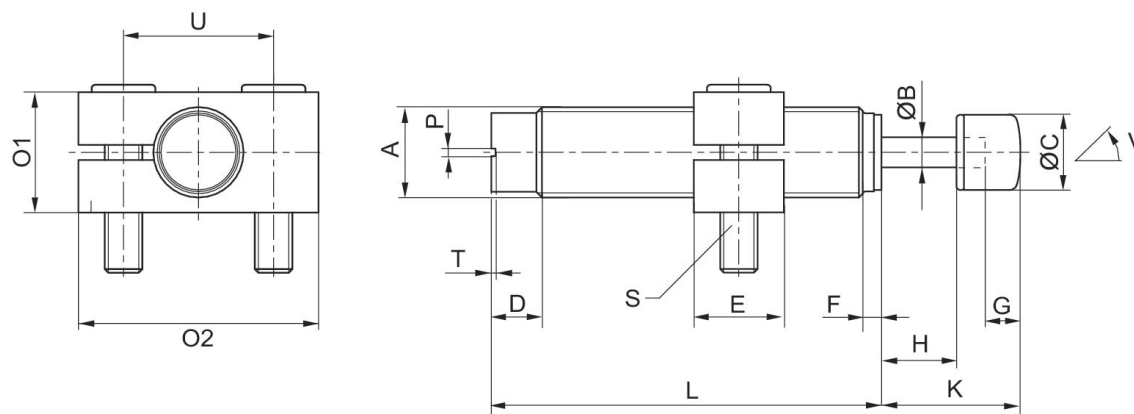

A = mounting thread
V = tilt

Part No.	Type	Mounting thread	ØB	ØC	D	E	F	G	H	K
R412010301	SA1-MC	M12x1	4	10	6	12	2.5	4	10	18.5
R412010302	SA1-MC	M12x1	4	10	6	12	2.5	4	10	18.5
R412010303	SA1-MC	M12x1	4	10	6	12	2.5	4	10	18.5

Part No.	L	O1	O2	P	S	T	U	W [°]
R412010301	52	32	16	1	M5x20	0.6	20	2
R412010302	52	32	16	1	M5x20	0.6	20	2
R412010303	52	32	16	1	M5x20	0.6	20	2

Industrial shock absorber, Series SA1-MC



Mounting thread	Stroke [mm]	Max. energy absorption/stroke [Nm]	Max. energy absorption/hour [Nm]	Effective mass m_e min. [kg]	Effective mass m_e max. [kg]	Min. return spring force [N]	Max. return spring force [N]	Part No.
M14x1,5	14	30	50000	3.5	17	13	23	R412010304
M14x1,5	14	30	50000	9.9	76	13	23	R412010305
M14x1,5	14	30	50000	62	252	13	23	R412010306

Dimensions

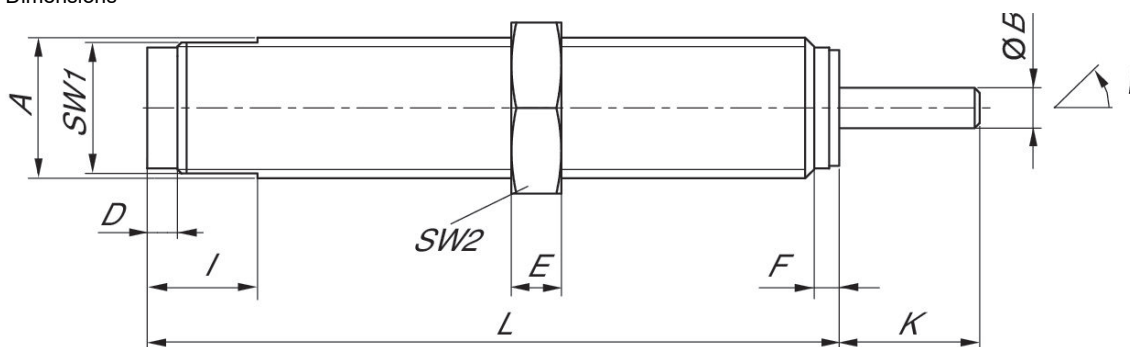

A = mounting thread
V = tilt

Part No.	Type	Mounting thread	ØB	D	E	F	I	K	L	SW1
R412010304	SA1-MC	M14x1,5	4	3	5	2.5	11	14	69	13
R412010305	SA1-MC	M14x1,5	4	3	5	2.5	11	14	69	13
R412010306	SA1-MC	M14x1,5	4	3	5	2.5	11	14	69	13

Part No.	SW2	W [°]
R412010304	17	4
R412010305	17	4
R412010306	17	4

Industrial shock absorber, Series SA1-MC



Mounting thread	Stroke [mm]	Max. energy absorption/stroke [Nm]	Max. energy absorption/hour [Nm]	Effective mass m_e min. [kg]	Effective mass m_e max. [kg]	Min. return spring force [N]	Max. return spring force [N]	Part No.
M20x1,5	13	65	52000	7.5	36	12	23	R412010307
M20x1,5	13	65	52000	20	160	12	23	R412010308
M20x1,5	13	65	52000	130	610	12	23	R412010309
M25x1,5	25	220	105600	24	120	15	31	R412010310
M25x1,5	25	220	105600	440	2050	15	31	R412010311
M25x1,5	25	220	105600	1760	10800	15	31	R412010312

Dimensions

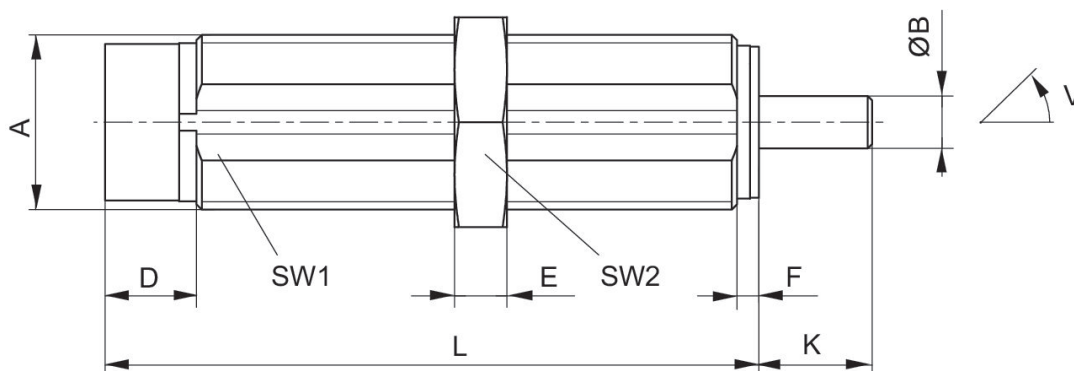

A = mounting thread
V = tilt

Part No.	Type	Mounting thread	ØB	D	E	F	K	L	SW1	SW2
R412010307	SA1-MC	M20x1,5	6	10.5	6	2.5	13	75	18	24
R412010308	SA1-MC	M20x1,5	6	10.5	6	2.5	13	75	18	24
R412010309	SA1-MC	M20x1,5	6	10.5	6	2.5	13	75	18	24
R412010310	SA1-MC	M25x1,5	8	9.5	8	3.5	25	108	23	30

Part No.	Type	Mounting thread	ØB	D	E	F	K	L	SW1	SW2
R412010311	SA1-MC	M25x1,5	8	9.5	8	3.5	25	108	23	30
R412010312	SA1-MC	M25x1,5	8	9.5	8	3.5	25	108	23	30

Part No.	W [°]
R412010307	4
R412010308	4
R412010309	4
R412010310	2
R412010311	2
R412010312	2

Industrial shock absorber, Series SA1-MC



Mounting thread	Stroke [mm]	Max. energy absorption/stroke [Nm]	Max. energy absorption/hour [Nm]	Effective mass m_e min. [kg]	Effective mass m_e max. [kg]	Min. return spring force [N]	Max. return spring force [N]	Part No.
M14x1,5	14	30	50000	3.5	17	13	23	R412010313
M14x1,5	14	30	50000	9.9	76	13	23	R412010314
M14x1,5	14	30	50000	62	252	13	23	R412010315

Dimensions

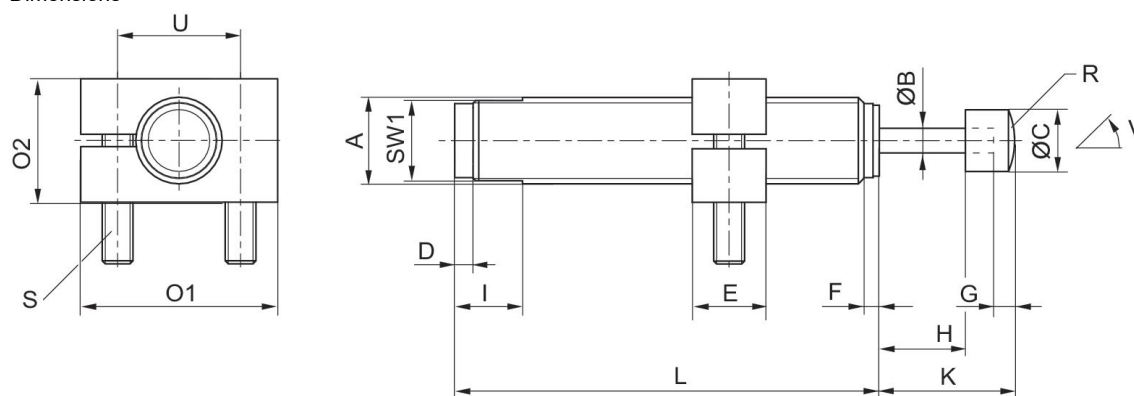

A = mounting thread
V = tilt

Part No.	Type	Mounting thread	ØB	ØC	D	E	F	G	H	I
R412010313	SA1-MC	M14x1,5	4	10	3	12	2.5	3.5	14	11
R412010314	SA1-MC	M14x1,5	4	10	3	12	2.5	3.5	14	11
R412010315	SA1-MC	M14x1,5	4	10	3	12	2.5	3.5	14	11

Part No.	K	L	O1	O2	R	S	SW1	U	W [°]
R412010313	22	69	32	20	13	M5x25	13	20	4
R412010314	22	69	32	20	13	M5x25	13	20	4
R412010315	22	69	32	20	13	M2x25	13	20	4

Industrial shock absorber, Series SA1-MC



Mounting thread	Stroke [mm]	Max. energy absorption/stroke [Nm]	Max. energy absorption/hour [Nm]	Effective mass m_e min. [kg]	Effective mass m_e max. [kg]	Min. return spring force [N]	Max. return spring force [N]	Part No.
M20x1,5	13	65	52000	7.5	36	12	23	R412010316
M20x1,5	13	65	52000	20	160	12	23	R412010317
M20x1,5	13	65	52000	130	610	12	23	R412010318
M25x1,5	25	220	105600	24	120	15	31	R412010319
M25x1,5	25	220	105600	440	2050	15	31	R412010320
M25x1,5	25	220	105600	1760	10800	15	31	R412010321

Dimensions

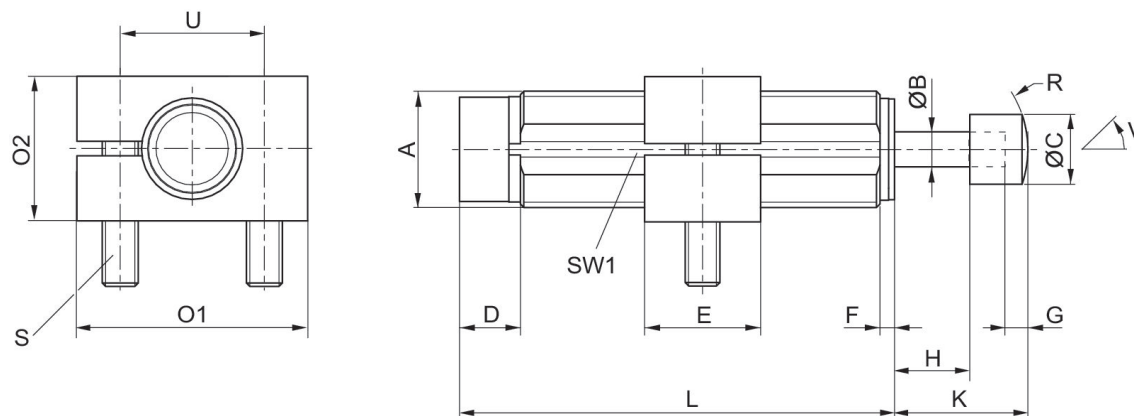

A = mounting thread
V = tilt

Part No.	Type	Mounting thread	ØB	ØC	D	E	F	G	H	K
R412010316	SA1-MC	M20x1,5	6	12	10.5	20	2.5	4	13	23
R412010317	SA1-MC	M20x1,5	6	12	10.5	20	2.5	4	13	23
R412010318	SA1-MC	M20x1,5	6	12	10.5	20	2.5	4	13	23
R412010319	SA1-MC	M20x1,5	8	16	9.5	25	3.5	5	25	38
R412010320	SA1-MC	M25x1,5	8	16	9.5	25	3.5	5	25	38
R412010321	SA1-MC	M25x1,5	8	16	9.5	25	3.5	5	25	38

Part No.	L	O1	O2	R	S	SW1	U	W [°]
R412010316	75	40	25	18.5	M6x30	18	28	4
R412010317	75	40	25	18.5	M6x30	18	28	4
R412010318	75	40	25	18.5	M6x30	18	28	4
R412010319	108	47	32	20	M6x40	23	34	2
R412010320	108	47	32	20	M6x40	23	34	2
R412010321	108	47	32	20	M6x40	23	34	2

Lock nut



Thread size	Material	Part No.
M6x0,5	Steel, chrome-plated	R412010359
M8x1	Steel, chrome-plated	R412010360
M10x1	Steel, chrome-plated	R412010361
M12x1	Steel, chrome-plated	R412010362
M14x1,5	Steel, chrome-plated	R412010363
M20x1,5	Steel, chrome-plated	R412010364
M25x1,5	Steel, chrome-plated	R412010365

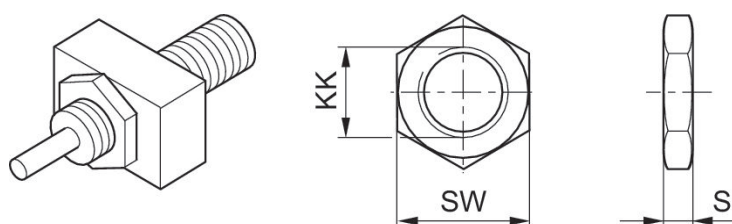

KK	Part No.	For series	S	SW
M6x0,5	R412010359	SA1-MC	3	8
M8x1	R412010360	SA1-MC	3	11
M10x1	R412010361	SA1-MC	3	13
M12x1	R412010362	SA1-MC	4	14
M14x1,5	R412010363	SA1-MC	5	17
M20x1,5	R412010364	SA1-MC	6	24
M25x1,5	R412010365	SA1-MC	8	30

Groove nut



Thread size	Material	Part No.
M33x1,5	Steel, chrome-plated	R412010331
M64x2	Steel, chrome-plated	R412010332

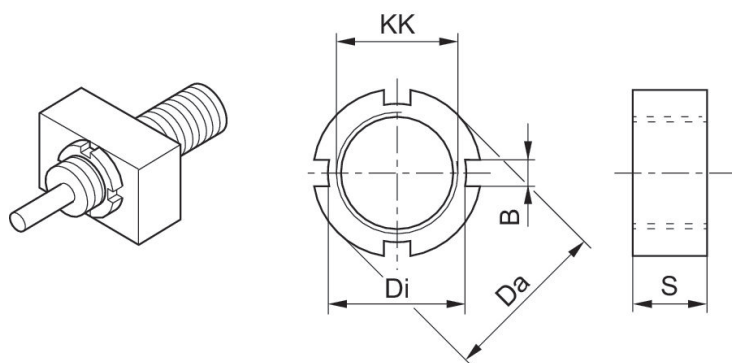

KK	Part No.	For series	Da	Di	B	S
M33x1,5	R412010331	SA1-MA	38	35	5	6.5
M64x2	R412010332	SA1-MA	74	71	10	10

Flange mounting



Material	Part No.
Steel, chrome-plated	R412010333
Steel, chrome-plated	R412010334

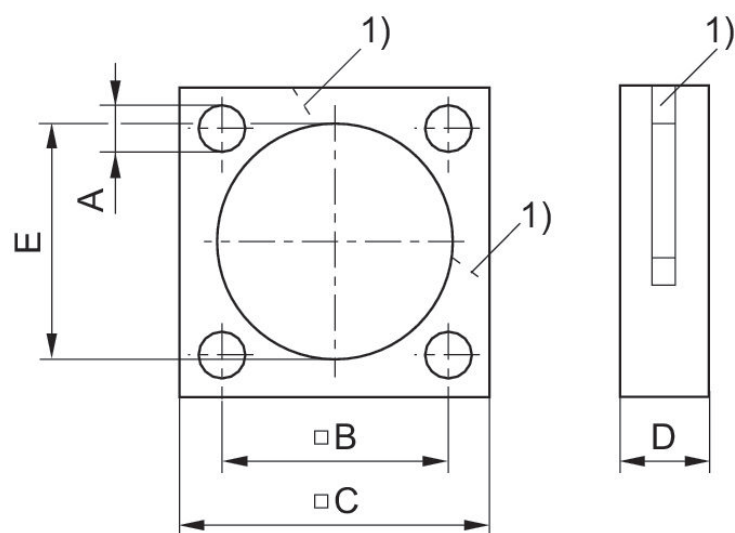

1) Clamping slot

Part No.	A	B	C	D	E
R412010333	6.6	32	45	12	M33x1,5
R412010334	11	58	80	16	M64x2

Clamping flange



Part No.
R412010341
R412010342

Dimensions

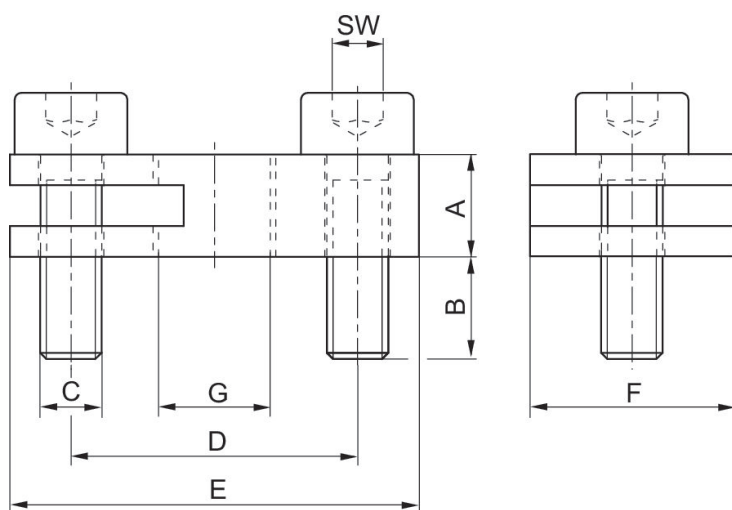

Part No.	A	B	C	D	E	F	G	SW
R412010341	5	5	M3x10	14	20	10	M6x0,5	2,5
R412010342	6	6	M4x12	18	25	15	M8x1	3

Clamping flange



Part No.
R412010343
R412010344
R412010345
R412010346
R412010347

Dimensions

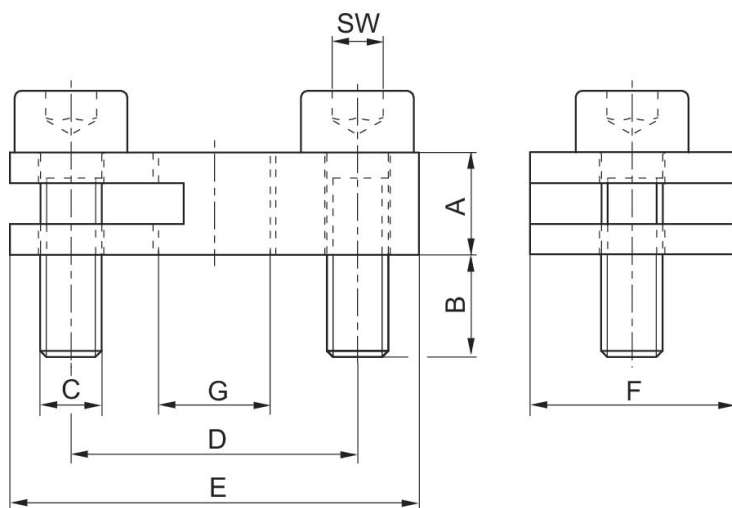

Part No.	A	B	C	D	E	F	G	H	SW
R412010343	14	6	M4x20	16	25	10	M10x1	2	3
R412010344	16	8	M5x20	20	32	12	M12x1	2	4
R412010345	20	10	M5x25	20	32	12	M14x1,5	2	4
R412010346	25	11	M6x30	28	40	20	M20x1,5	2	5
R412010347	32	14	M6x40	34	47	25	M25x1,5	2	5

Clamping flange



Part No.
R412010348
R412010349

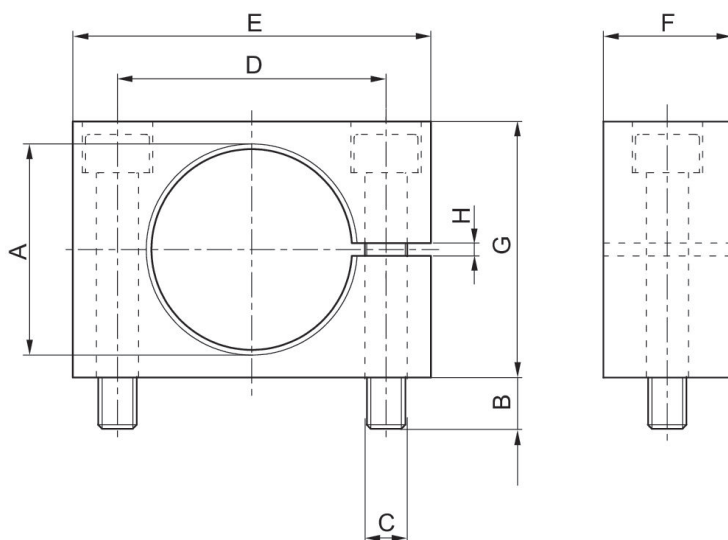

Part No.	A	B	C	D	E	F	G	H
R412010348	M33x1,5	8	M6x40	42	56	20	40	2
R412010349	M64x2	12	M10x80	78	100	25	80	2

Stop head

SA1-MC



Scope of delivery [piece]	Part No.
5	R412010356
5	R412010357
5	R412010358

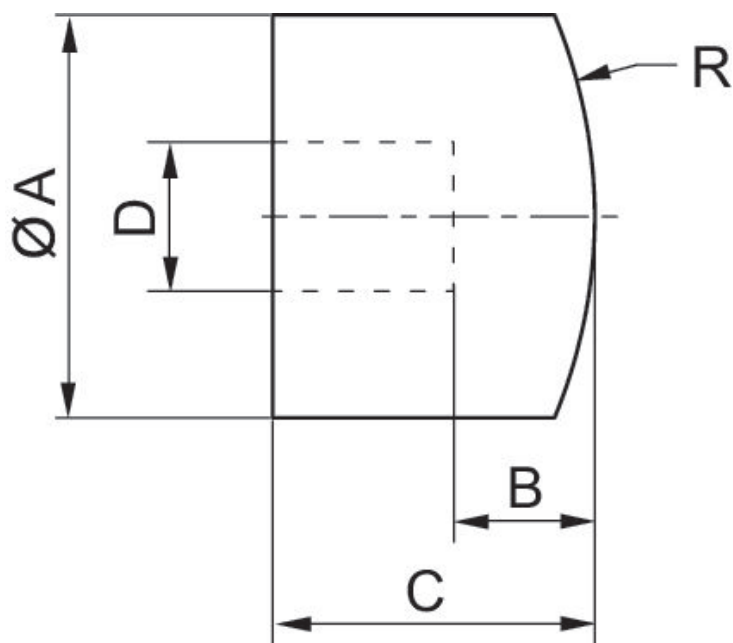

Part No.	$\varnothing A$	B	C	D 1)	R
R412010356	10	3.5	8	4	13
R412010357	12	4	10	6	18.5
R412010358	16	5	13	8	20
1820508008	12	5	10	-	-
1820508009	17	4	9	-	-
1820508010	23	6	12	-	-

1) Rod diameter

Stop sleeve

SA1-MC



Scope of delivery [piece]	Part No.
2	R412010335
2	R412010336
2	R412010337
2	R412010338
2	R412010339
2	R412010340

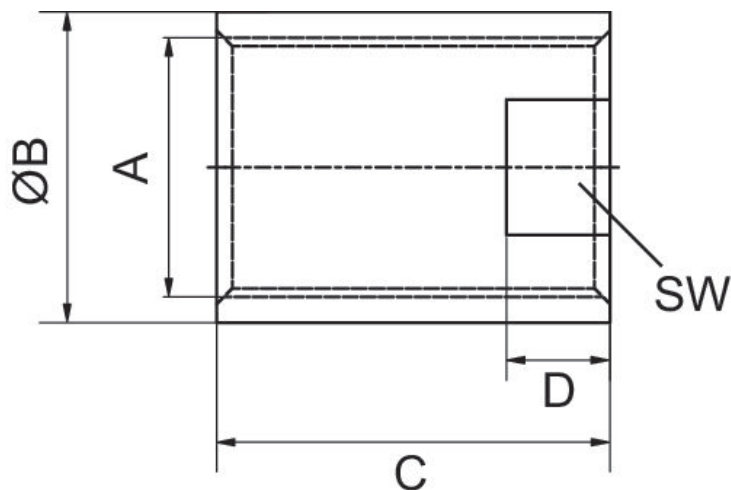

Part No.	A	ØB	C	D	SW
R412010335	M8x1	11	12	-	-
R412010336	M10x1	14	15	-	-
R412010337	M12x1	16	20	-	-
R412010338	M14x1,5	18	20	6	15
R412010339	M20x1,5	25	35	8	22
R412010340	M25x1,5	30	38	10	30
1820360039	M8x1	10	6	12	-
1820360040	M10x1	12,5	10	20	-
1820360041	M12x1	15	10	20	-

Part No.	A	ØB	C	D	SW
1820360042	M14x1,5	17	8	20	15
1820360043	M20x1,5	24,8	13	25	22
1820360044	M25x1,5	30	16	32	27

Side load adapter

SA1-MC



External Ø [mm]	Scope of delivery [piece]	Part No.
12	1	R412010350
14	1	R412010351
15	1	R412010352
18	1	R412010353
24	1	R412010354
30	1	R412010355

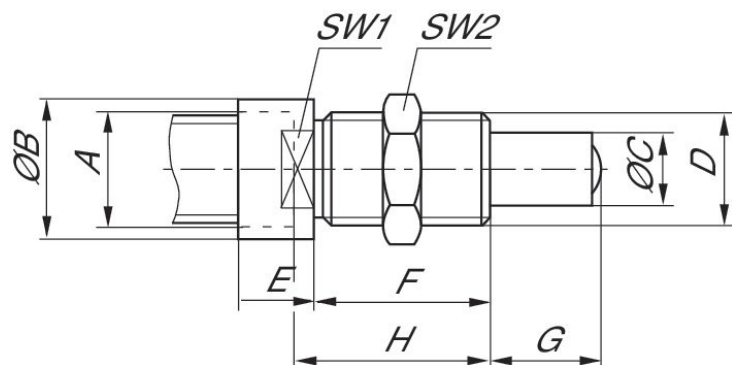

Part No.	A	ØB	ØC	D	E	F	G	H	SW1	SW2
R412010350	M8x1	12	4	M8x1	6	10	5	13	10	11
R412010351	M10x1	14	6	M10x1	7	12	8	15	13	13
R412010352	M12x1	15	7	M12x1	7	18	10	21	14	14
R412010353	M14x1,5	18	8	M14x1,5	8	20	14	24	16	17
R412010354	M20x1,5	24	12	M20x1,5	9	20	13	25	22	24
R412010355	M25x1,5	30	16	M25x1,5	13	38	25	41	27	30

Efficient pneumatic solutions, our program: cylinders and drives, valves and valve systems, air supply management



Visit us: [Emerson.com/Aventics](https://www.emerson.com/aventics)

Your local contact: [Emerson.com/contactus](https://www.emerson.com/contactus)



[Emerson.com](https://www.emerson.com)



[Facebook.com/EmersonAutomationSolutions](https://www.facebook.com/EmersonAutomationSolutions)



[LinkedIn.com/company/Emerson-Automation-Solutions](https://www.linkedin.com/company/Emerson-Automation-Solutions)



[Twitter.com/EMR_Automation](https://twitter.com/EMR_Automation)

An example configuration is depicted on the title page. The delivered product may thus vary from that in the illustration. Subject to change. This Document, as well as the data, specifications and other information set forth in it, are the exclusive property of AVENTICS GmbH. It may not be reproduced or given to third parties without its consent. Only use the AVENTICS products shown in industrial applications. Read the product documentation completely and carefully before using the product. Observe the applicable regulations and laws of the respective country. When integrating the product into applications, note the system manufacturer's specifications for safe use of the product. The data specified only serve to describe the product. No statements concerning a certain condition or suitability for a certain application can be derived from our information. The information given does not release the user from the obligation of own judgment and verification. It must be remembered that the products are subject to a natural process of wear and aging.

The Emerson logo is a trademark and service mark of Emerson Electric Co. Brand logotype are registered trademarks of one of the Emerson family of companies. All other marks are the property of their respective owners. © 2019 Emerson Electric Co. All rights reserved.



EMERSON™

CONSIDER IT SOLVED™