

万向头



AVENTICS™

AVENTICS 杆端鱼眼接头



万向头



回转头AP6 , CM2 系列



用于系列	万向轴承-Ø [mm]	材料	物料号
MNI, SSI	5	钢, 镀铬	1822124000
MNI, CCI, SSI	6	钢, 镀铬	1822124001
MNI, CCI, SSI, KPZ	8	钢, 镀铬	1822124002
	10	钢, 镀铬	8958206402
KHZ	12	钢, 镀铬	8958208852
PRA, TRB, MNI, CCI, SSI, RPC, KPZ, 167, CVI, RDC	10	钢, 镀铬	1822124003
PRA, TRB, CCI, SSI, RPC, KPZ, 167, CVI, 102	12	钢, 镀铬	1822124004
PRA, TRB, CCI, SSI, RPC, KPZ, 167, CVI, RDC, 102	16	钢, 镀铬	1822124005
PRA, TRB, KPZ, 167, CVI, 102	20	钢, 镀铬	1822124006
	25	钢, 镀铬	8958208002
PRA, TRB, 167, CVI	30	钢, 镀铬	1822124013
ITS	35	钢, 镀铬	1822124008
ITS	40	钢, 镀铬	1822124009
ITS	50	钢, 镀铬	8958208842

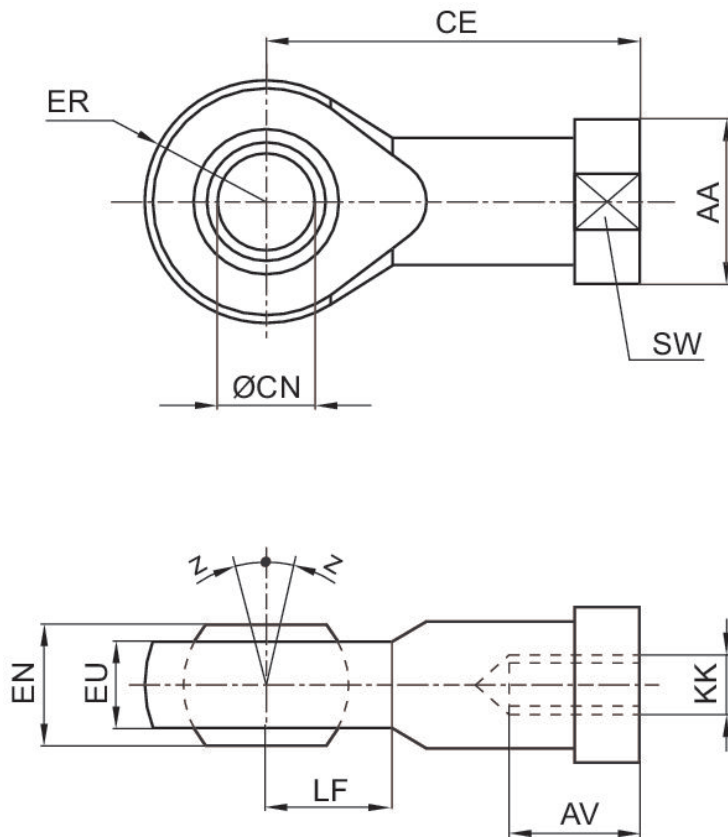

KK	物料号	AA	AV min.	CE	Ø CN H7	EN -0,1	ER	EU max.	LF	SW
M4	1822124000	12	8	27	5	8	9	7.5	9	9
M6	1822124001	13	9	30	6	9	10	7.5	10	11
M8	1822124002	16	12	36	8	12	12	9.5	12	14
M10	8958206402	19	20	43	10	14	14	10.5	13	17
M12	8958208852	22	22	50	12	16	16	12	16	19
M10x1,25	1822124003	19	15	43	10	14	14	11.5	14	17
M12x1,25	1822124004	22	18	50	12	16	16	12.5	16	19
M16x1,5	1822124005	27	24	64	16	21	21	15.5	21	22
M20x1,5	1822124006	34	30	77	20	25	25	18.5	25	30
M24x2	8958208002	42	36	94	25	31	30	23	30	36
M27x2	1822124013	50	45	110	30	37	35	27	35	41
M36x2	1822124008	60	56	125	35	43	40	32	40	50
M42x2	1822124009	69	60	142	40	49	45.5	37	45	55
M48x2	8958208842	75	65	160	50	60	58	45	60	65

KK	Z [°] max.
M4	4
M6	4
M8	4
M10	6

KK	Z [°] max.
M12	13
M10x1,25	4
M12x1,25	4
M16x1,5	4
M20x1,5	4
M24x2	15
M27x2	4
M36x2	4
M42x2	4
M48x2	6

回转头AP6，CM2 系列

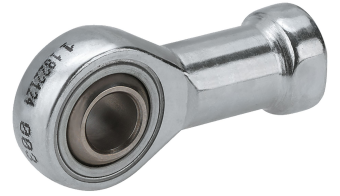

用于系列	万向轴承-Ø [mm]	材料	物料号
ICM	5	不锈钢	8958209002
CCL-IC, CSL-RD, ICM	6	不锈钢	8958209012
CCL-IC, CSL-RD, ICM	8	不锈钢	8958209022
CCL-IS, CCL-IC, SSI, CSL-RD, ICM, ICS-D2	10	不锈钢	8958209032
CCL-IS, CCL-IC, SSI, ICS-D2	12	不锈钢	8958209042
CCL-IS, CCL-IC, SSI, ICS-D2	16	不锈钢	8958209052
CCL-IS, SSI, ICS-D2	20	不锈钢	8958209062
CCL-IS	30	不锈钢	8958209072

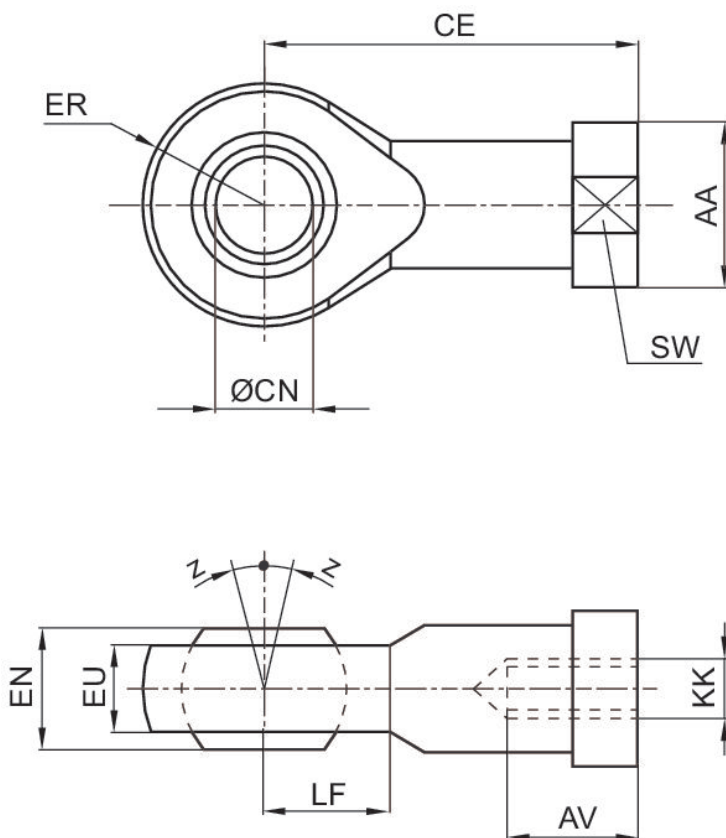

KK	物料号	AA	AV min.	CE	Ø CN H7	EN -0,1	ER	EU max.	LF	SW
M4	8958209002	11	8	27	5	8	9	6	9	9
M6	8958209012	13	9	30	6	9	10	6,75	10	11
M8	8958209022	16	12	36	8	12	12	9	12	14
M10x1,25	8958209032	19	15	43	10	14	14	10,5	14	17
M12x1,25	8958209042	22	18	50	12	16	16	12	16	19
M16x1,5	8958209052	27	24	64	16	21	21	15	21	22
M20x1,5	8958209062	34	30	77	20	25	25	18	25	30
M27x2	8958209072	50	45	110	30	37	35	25	35	41

KK	Z [°] max.
M4	6,5
M6	6,5
M8	6,5
M10x1,25	6,5
M12x1,25	6,5
M16x1,5	7,5
M20x1,5	7,5
M27x2	7,5

回转头AP6，CM2 系列



万向轴承-Ø [mm]	材料	物料号
10	不锈钢	2990690903
12	不锈钢	2990690904
16	不锈钢	2990690905
20	不锈钢	2990690908
30	不锈钢	2990600912
35	不锈钢	2990600916

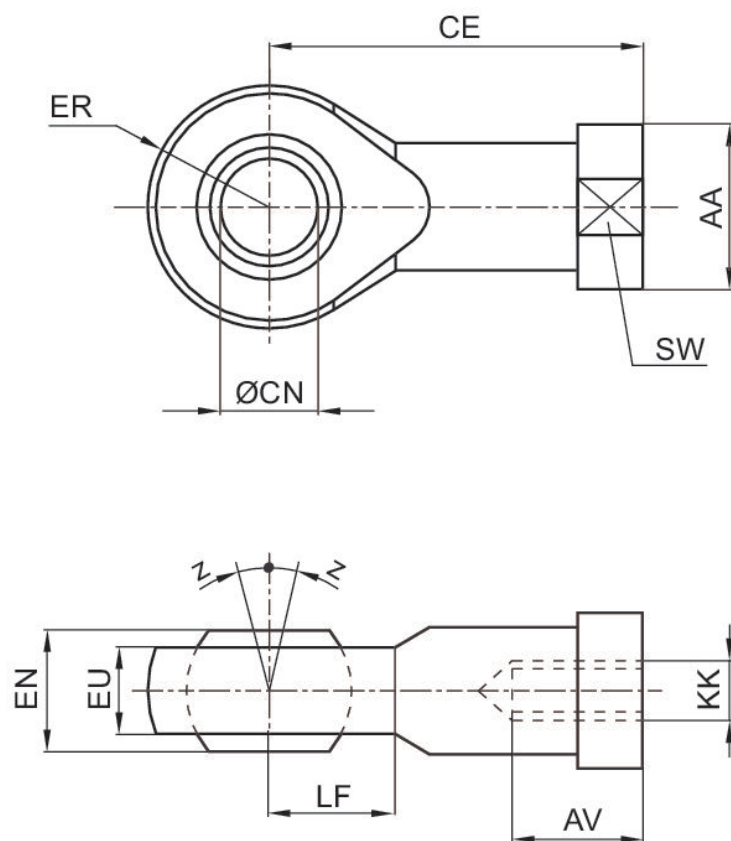

KK	物料号	AA	AV min.	CE	Ø CN H7	EN -0,1	ER	EU max.	LF	SW
M10x1,25	2990690903	19	20	43	10	14	14	10.5	13	17
M12x1,25	2990690904	22	22	50	12	16	16	12	16	19
M16x1,5	2990690905	27	28	64	16	21	21	15	21	22
M20x1,5	2990690908	34	33	77	20	25	25	18	25	32
M27x2	2990600912	51	51	110	30	37	35	18	36	41
M36x2	2990600916	58	60	125	35	35	42,5	21	45	50

KK	Z [°] max.
M10x1,25	7
M12x1,25	7
M16x1,5	8
M20x1,5	8
M27x2	4
M36x2	6

回转头AP6，CM2 系列



用于系列	万向轴承-Ø [mm]	材料	物料号
ITS, CCL-IC/-IS, CCI, KPZ	35	钢, 镀铬	3660916000
PRA, TRB, CCI, SSI, RPC, KPZ, 167, CVI, RDC	10	钢, 镀铬	3660902000
PRA, TRB, CCI, SSI, RPC, KPZ, 167, CVI, 102	12	钢, 镀铬	3660904000
PRA, TRB, CCI, SSI, RPC, KPZ, 167, CVI, RDC, 102	16	钢, 镀铬	3660905000
PRA, TRB, KPZ, 167, CVI, 102	20	钢, 镀铬	3660908000
102, CCL-IC/-IS, CCI, KPZ	25	钢, 镀铬	3660912000

规格

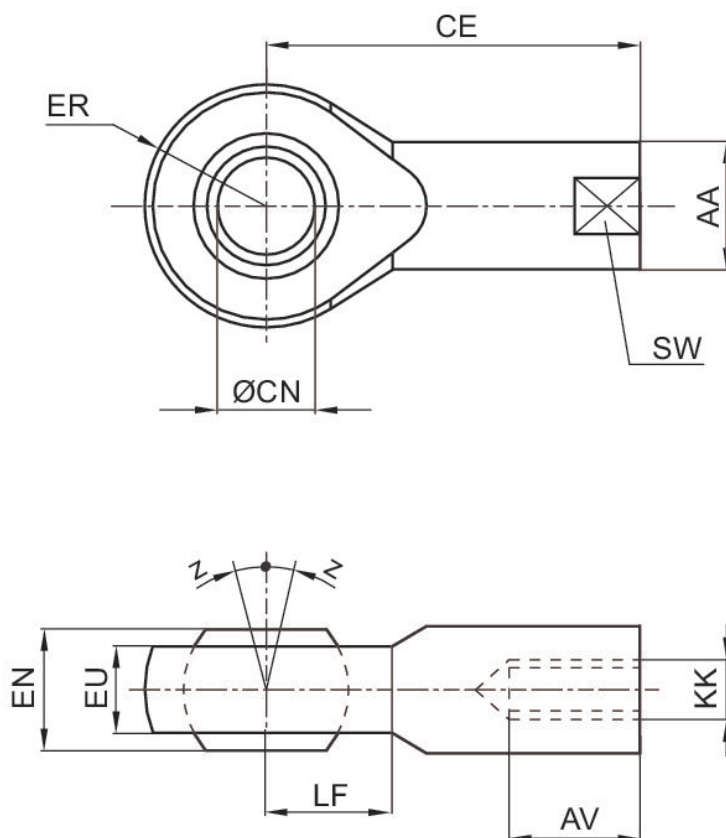

KK	物料号	AA	AV min.	CE	Ø CN H7	EN -0,1	ER	EU max.	LF	SW
M10x1.25	3660902000	19	15	43	10	12	15	9	14	17
M12x1.25	3660904000	22	16	50	12	12	17	8	16	19

KK	Z [°] max.
M10x1.25	8
M12x1.25	8

活塞杆终端件



材料	物料号
钢, 镀铬	7472ZZ5700
钢, 镀铬	7472ZZ1445
钢, 镀铬	7472ZZ1446
钢, 镀铬	7472ZZ1447
钢, 镀铬	7472ZZ1448
钢, 镀铬	7472ZZ1449

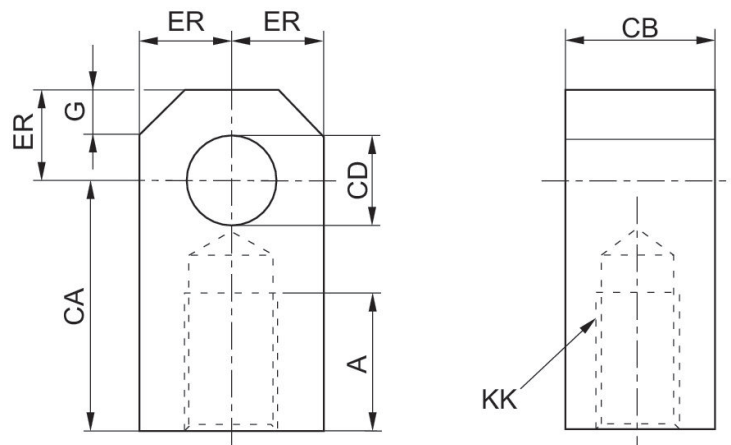

KK	物料号	∅	A	CA	CB	CD	ER	G
M10x1,5	7472ZZ1445	25 32	20	36	11	8	9	3
M16x1,5	7472ZZ1446	40 50	30	51	18	12	13	7
M20x1,5	7472ZZ1447	63 80	36	63	22	16	17	10
M27x2	7472ZZ1448	100 125	50	85	30	20	20	13
M36x2	7472ZZ1449	160 200	70	115	40	25	25	15

配有内螺纹的活塞杆上端

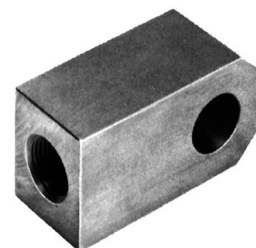

材料	物料号
钢, 镀铬	R432006533
钢, 镀铬	R432013437
钢, 镀铬	R433012611
钢, 镀铬	R433012612
钢, 镀铬	R433012613
钢, 镀铬	R433012614
钢, 镀铬	R433012615

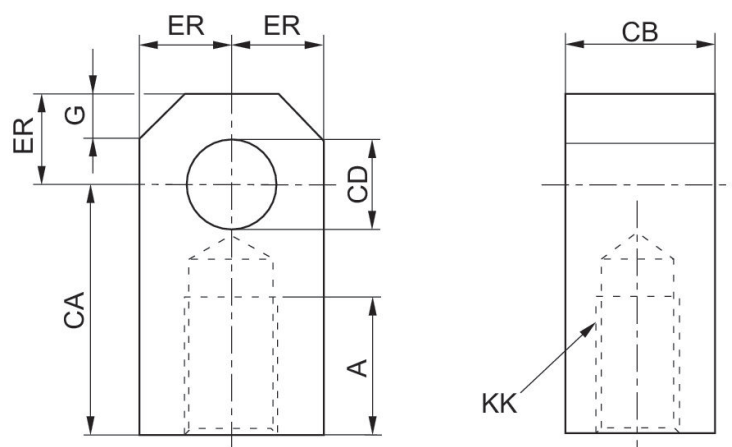

尺寸按英寸

物料号	∅	A	CA	CB	CD	ER	KK
R432006533	1.50 2.00 2.50	0.88	1.50	0.75	0.50	0.56	1/2-20
R432013437	3.25 4.00	1.13	2.06	1.25	0.75	0.84	7/8-14

带滚珠轴承的万向轴



物料号
R433013001
R433012998
R433012999

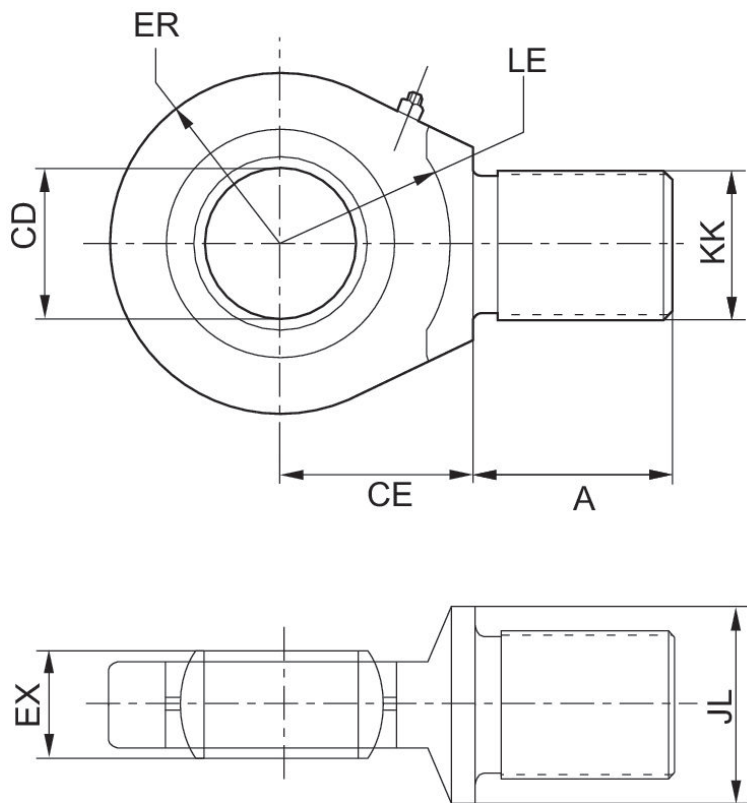

尺寸按英寸

	A	JL	CD +0,0000/-0,0005	CF	EX	ER (max.)	LE
R433013001	0.69	0.88	0.5	0.88	0.44	0.88	0.75
R433012998	1	1.31	0.75	1.25	0.66	1.25	1.06
R433012999	1.5	1.5	1	1.88	0.88	1.38	1.44

Efficient pneumatic solutions, our program: cylinders and drives, valves and valve systems, air supply management



Visit us: [Emerson.com/Aventics](https://www.emerson.com/Aventics)

Your local contact: [Emerson.com/contactus](https://www.emerson.com/contactus)



[Emerson.com](https://www.emerson.com)



[Facebook.com/EmersonAutomationSolutions](https://www.facebook.com/EmersonAutomationSolutions)



[LinkedIn.com/company/Emerson-Automation-Solutions](https://www.linkedin.com/company/Emerson-Automation-Solutions)



[Twitter.com/EMR_Automation](https://twitter.com/EMR_Automation)

An example configuration is depicted on the title page. The delivered product may thus vary from that in the illustration. Subject to change. This Document, as well as the data, specifications and other information set forth in it, are the exclusive property of AVENTICS GmbH. It may not be reproduced or given to third parties without its consent. Only use the AVENTICS products shown in industrial applications. Read the product documentation completely and carefully before using the product. Observe the applicable regulations and laws of the respective country. When integrating the product into applications, note the system manufacturer's specifications for safe use of the product. The data specified only serve to describe the product. No statements concerning a certain condition or suitability for a certain application can be derived from our information. The information given does not release the user from the obligation of own judgment and verification. It must be remembered that the products are subject to a natural process of wear and aging.

The Emerson logo is a trademark and service mark of Emerson Electric Co. Brand logotype are registered trademarks of one of the Emerson family of companies. All other marks are the property of their respective owners. © 2019 Emerson Electric Co. All rights reserved.



CONSIDER IT SOLVED™