

Fixations à tourillon

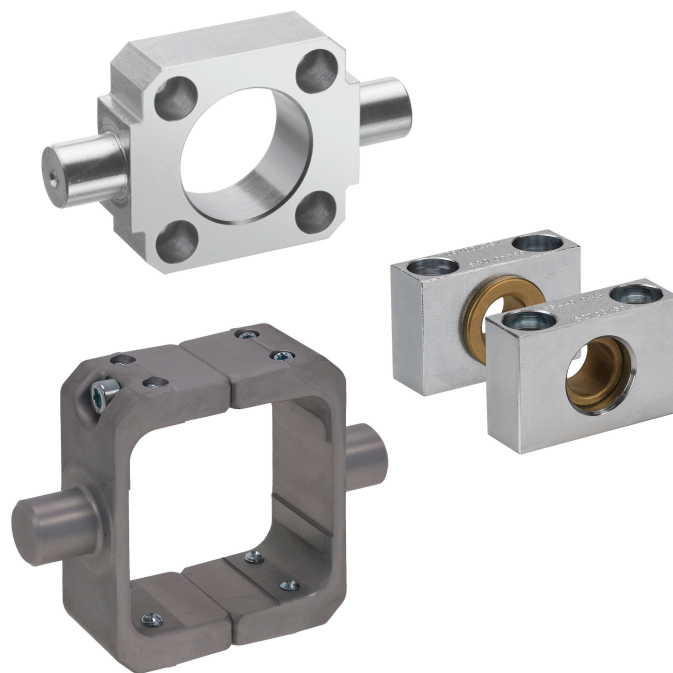

Fixations à tourillon

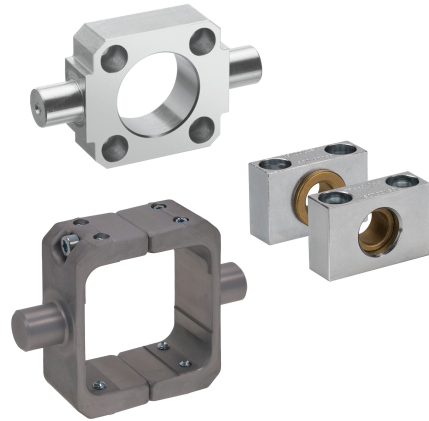

Tourillon MT4, Série CM1

167



Diamètre de piston [mm]	Matériau	Référence
32	Acier, chromé	3672803000
40	Acier, chromé	3672804000
50	Acier, chromé	3672805000
63	Acier, chromé	3672806000
80	Acier, chromé	3672808000
100	Acier, chromé	3672810000

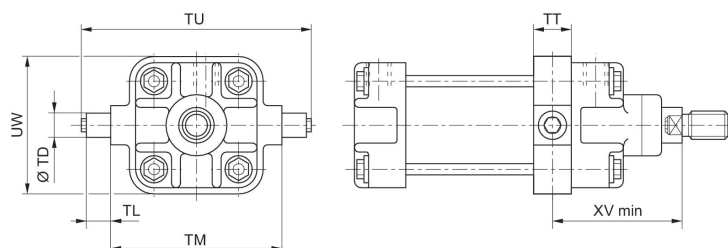

Ø du piston	Référence	TT	TD e9	TL h14	TM h14	TU	UW	XV min
32	3672803000	16	12	12	50	74	48	61,5
40	3672804000	23	16	16	63	95	61	74,5
50	3672805000	23	16	10	75	107	71	79,5
63	3672806000	33	20	20	90	130	86	91,5
80	3672808000	33	20	20	110	150	112	100,5
100	3672810000	45	25	25	132	182	134	115,5

Tourillon MT4, Série CM1

PRA

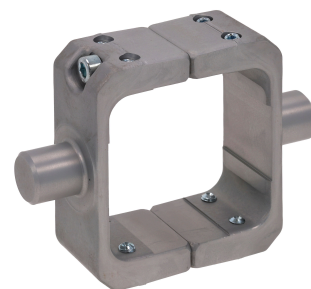

Diamètre de piston [mm]	Matériau	Référence
32	Aluminium	1827003991
40	Aluminium	1827003992
50	Aluminium	1827003993
63	Aluminium	1827003994
80	Aluminium	1827003995
100	Aluminium	1827003996
125	Aluminium	1827003997

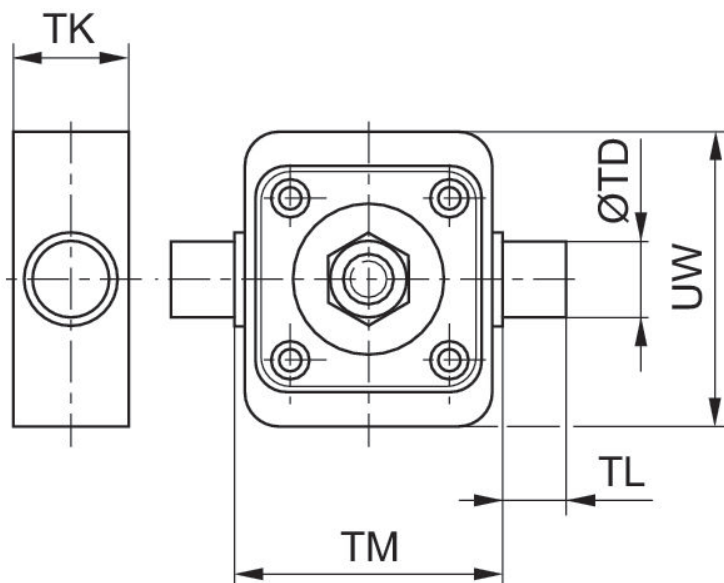

Ø du piston	Référence	TD e9	TK Maxi	TL h14	TM h14	UW
32	1827003991	12	22	12	50	64
40	1827003992	16	27	16	63	72
50	1827003993	16	27	16	75	90
63	1827003994	20	35	20	90	102
80	1827003995	20	35	20	110	125
100	1827003996	25	46	25	132	147

Ø du piston	Référence	TD e9	TK Maxi	TL h14	TM h14	UW
125	1827003997	25	46	25	160	178

Tourillon MT5, MT6, Série CM1

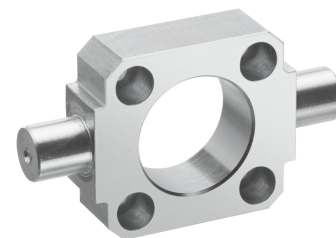

Diamètre de piston [mm]		Matériau	Référence
20		Fonte à graphite sphéroïdal	1825805360
25		Fonte à graphite sphéroïdal	1825805361
25		Aluminium	R412026354
32		Fonte à graphite sphéroïdal	1825805362
32		Fonte à graphite sphéroïdal	1827001609
40		Fonte à graphite sphéroïdal	1825805363
40		Fonte à graphite sphéroïdal	1827001610
50		Fonte à graphite sphéroïdal	1825805364
50		Fonte à graphite sphéroïdal	1827001611
63		Fonte à graphite sphéroïdal	1825805365
63		Fonte à graphite sphéroïdal	1827002046
80		Fonte à graphite sphéroïdal	1825805366
80		Fonte à graphite sphéroïdal	1827001613
100		Fonte à graphite sphéroïdal	1825805367
100		Fonte à graphite sphéroïdal	1827001614
125		Fonte à graphite sphéroïdal	1827001615
160		Fonte à graphite sphéroïdal	1827001616
200		Fonte à graphite sphéroïdal	1827001617
250		Fonte à graphite sphéroïdal	1827001618

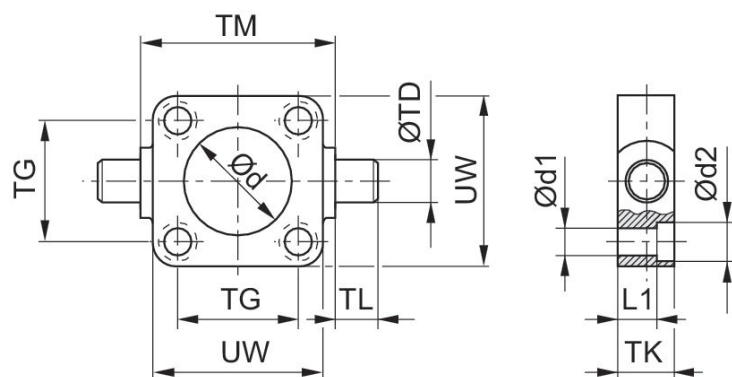

Ø du piston	Référence	Ø d H11	Ø d1	Ø d2	L1	TD e9	TG ±0,2	TK	TL h14	TM h14
20	1825805360	18	5.5	10	8	12	22	14	12	38
25	1825805361	22	5.5	10	8	12	26	14	12	42
25	R412026354	24	5.5	10	8	12	26	14	12	42
32	1825805362	32	6.6	10.5	7	12	32	14	12	52
32	1827001609	30	6.6	11	7.5	12	32.5	16	12	50
40	1825805363	46	6.6	11	12	16	42	19	16	63
40	1827001610	35	6.6	11	7.5	16	38	20	16	63
50	1825805364	53	9	14	10	16	50	19	16	75
50	1827001611	40	9	15	10	16	46.5	24	16	75
63	1825805365	69	9	15	15	20	62	24	20	90
63	1827002046	45	9	15	10	20	56.5	24	20	90
80	1825805366	87	11	18	13	20	82	24	20	110
80	1827001613	45	11	18	16	20	72	28	20	110
100	1825805367	55	11	18	18	25	103	29	25	132
100	1827001614	55	11	18	25.5	25	89	38	25	132
125	1827001615	60	14	20	34	25	110	46	25	160
160	1827001616	65	18	26	38	32	140	50	32	200
200	1827001617	75	18	26	40	32	175	60	32	250
250	1827001618	90	22	33	57	40	220	70	40	320

Ø du piston	UW
20	35
25	39
25	39
32	46
32	48
40	59
40	56
50	69
50	65
63	84
63	75
80	102
80	100
100	125
100	120
125	145
160	184
200	224
250	286

Palier, Série CM1



Diamètre de piston [mm]	Ø tenon à rotule [mm]	Matériau	Référence
25	10	Aluminium	3671202000
32	12	Aluminium	3671203000
40, 50	16	Aluminium	3671204000
63, 80	20	Aluminium	3671206000
100, 125	25	Aluminium	3671210000
100	30	Aluminium	3671212000
160, 200	32	Aluminium	3671216000
250, 320	35	Aluminium	3671220000

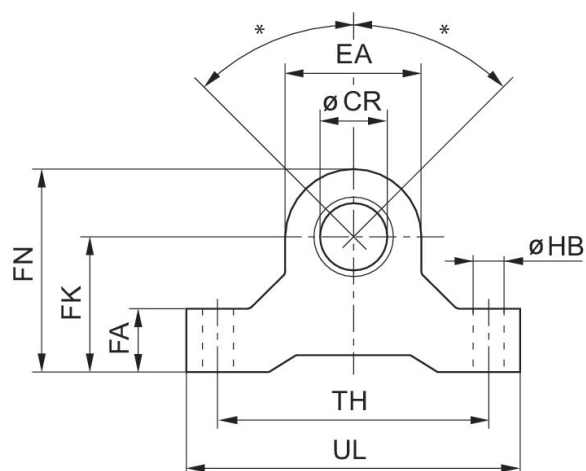

* Mouvement oscillant max. pour vérins avec cahpe arrière MP6 par tenon à rotule : ±45°

Ø du piston	Référence	Ø CR H8	EA	FA	FK ±0,1	FN	HB	NH	TH	UL
25	3671202000	10	16	10	21	29	5.5	10	27	37
32	3671203000	12	19	11	22	32	6.6	11	44	55
40, 50	3671204000	16	28	16	35	49	9	16	65	82
63, 80	3671206000	20	38	19	40	59	9	19	80	99
100, 125	3671210000	25	46	22	48	71	11	22	96	118
100	3671212000	30	56	28	57	88	13	28	114	142
160, 200	3671216000	32	66	32	70	103	17	32	140	172
250, 320	3671220000	35	66	32	70	103	17	32	140	172

Palier AT4, Série CM1

ISO 15552



Diamètre de piston [mm]	Ø tenon à rotule [mm]	Normalisation	Matériau	Référence
20, 25, 32	12	ISO 15552	Acier, chromé	1827001603
40, 50	16	ISO 15552	Acier, chromé	1827001604
63, 80	20	ISO 15552	Acier, chromé	1827001605
100, 125	25	ISO 15552	Acier, chromé	1827001606
160, 200	32	ISO 15552	Acier, chromé	1827001607
250	40	ISO 15552	Acier, chromé	R412018908
320	40	ISO 15552	Acier, chromé	R412018903

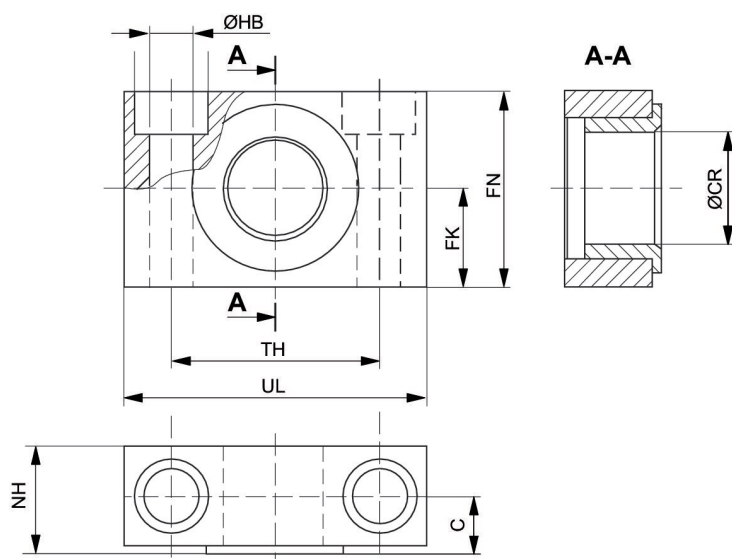

Ø du piston	Référence	UL	NH	TH	C	CR H9	HB H13	FN	FK
20, 25, 32	1827001603	46	18	32 ±0,2	10.5	12	6.6	30	15 ±0,1
40, 50	1827001604	55	21	36 ±0,2	12	16	9	36	18 ±0,1
63, 80	1827001605	65	23	42 ±0,2	13	20	11	40	20 ±0,1
100, 125	1827001606	75	28.5	50 ±0,2	16	25	14	50	25 ±0,1
160, 200	1827001607	92	40	60 ±0,3	22.5	32	18	60	30 ±0,2
250	1827001608	140	50	90 ±0,3	27.5	40	22	70	35 ±0,2

Ø du piston	Référence	UL	NH	TH	C	CR H9	HB H13	FN	FK
320	R412018903	150	60	100	32.5	50	26	80	40

Tourillon MP2, Série CM1

RPC

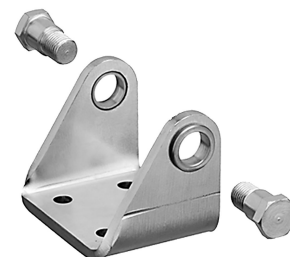

Diamètre de piston [mm]	Matériau	Référence
32	Acier, chromé	R412019988
40	Acier, chromé	R412019989
50	Acier, chromé	R412019990
63	Acier, chromé	R412019991

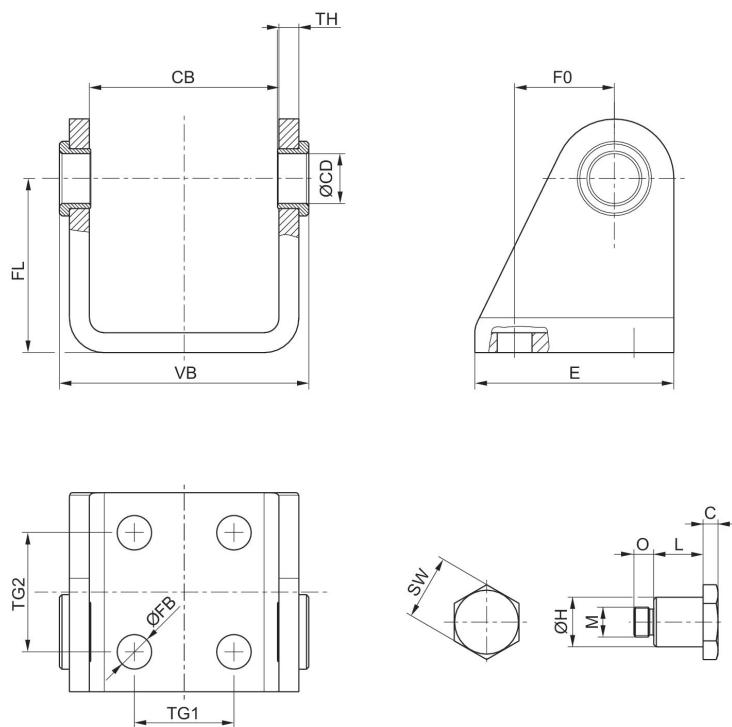

Ø du piston	Référence	C	CB	Ø CD H9	E	Ø FB	FL	F0	Ø H e9	L
32	R412019988	3	38.1	10	40	7	35	20	10	9.9
40	R412019989	3	46.1	12	50	9	40	27	12	10.4
50	R412019990	4	57.1	14	54	9	45	30	14	12.9
63	R412019991	4	70.1	16	65	9	50	34	16	13.9

Ø du piston	M	O	SW	TG1	TG2	TH	VB
32	M6x0,5	4	13	20	24	4	50.1
40	M6x0,5	4	17	28	30	5	60.1
50	M8x0,75	7	19	36	34	6	74.1
63	M8x0,75	7	19	42	35	6	87.1

Boulons de fixation



Diamètre de piston [mm]	Matériau	Référence
32	Acier inoxydable	2992113030
40	Acier inoxydable	2992113040
50	Acier inoxydable	2992113050
63	Acier inoxydable	2992113060
80	Acier inoxydable	2992113080

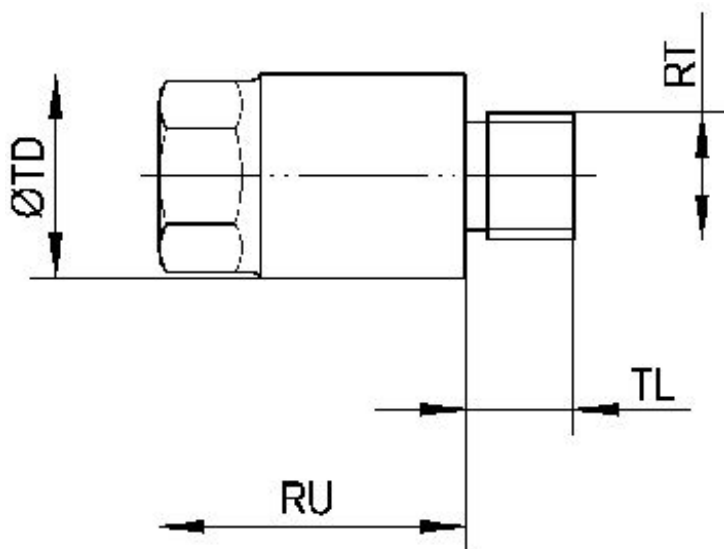

Ø du piston	Référence	RT	RU	Ø TD h9	TL
32	2992113030	M6x0,5	17	12	5
40	2992113040	M6x0,5	17	12	6
50	2992113050	M8x0,75	20	16	7.5
63	2992113060	M10x1	24	16	8.5
80	2992113080	M12x1	27	16	16

Tourillon, Série MT1, MT2

NFPA
TaskMaster®



Diamètre de piston [mm]	Matériau	Référence
38.1	Aluminium coulé sous pression	R432013510
50.8	Aluminium coulé sous pression	R432013507
63.5	Aluminium coulé sous pression	R432013513
82.55	Aluminium coulé sous pression	R432013489
101.6	Aluminium coulé sous pression	R432013516

Fig. 2

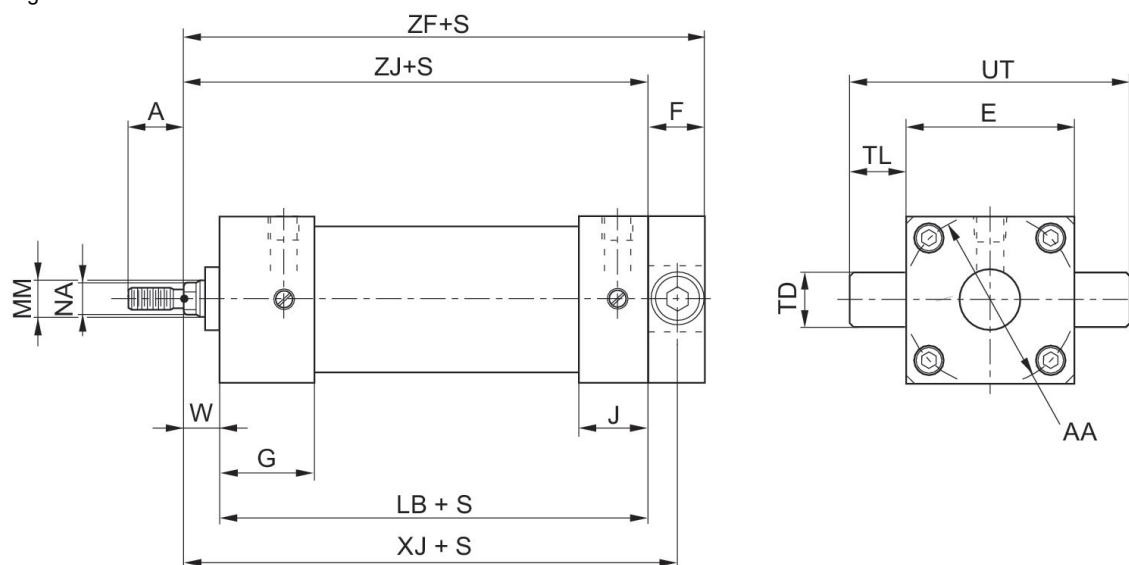

S = course

Dimensions en pouce

Ø	Référence	MM	E	F	W	AA	LB	TD	TL	UT
1.5	R432013510	0.625	2.00	1.00	1.38	2.02	3.98	1.00	1.00	4.00
2.0	R432013507	0.625	2.5	1.00	1.38	2.6	3.98	1.00	1.00	4.5
2.5	R432013513	0.625	3.00	1.00	1.38	3.1	4.1	1.00	1.00	5.00
3.25	R432013489	1.00	3.75	1.00	1.5	3.90	4.86	1.00	1.00	5.77
4.0	R432013516	1.00	4.50	1.00	1.5	4.70	4.86	1.00	1.00	6.49

Ø	XJ	ZF	ZJ
1.5	5.1	5.63	4.6
2.0	5.1	5.63	4.6
2.5	5.22	5.75	4.72
3.25	6.11	6.63	5.61
4.0	6.11	5.63	5.61

Dimensions en pouce

Ø	Référence	MM	E	F	W	AA	LB	TD	TL	UT
1.5	R432013510	0.625	2.00	1.00	1.38	2.02	3.98	1.00	1.00	4.00
2.0	R432013507	0.625	2.5	1.00	1.38	2.6	3.98	1.00	1.00	4.5
2.5	R432013513	0.625	3.00	1.00	1.38	3.1	4.1	1.00	1.00	5.00
3.25	R432013489	1.00	3.75	1.00	1.5	3.90	4.86	1.00	1.00	5.77
4.0	R432013516	1.00	4.50	1.00	1.5	4.70	4.86	1.00	1.00	6.49

Ø	XG	ZJ
1.5	0.12	5.6
2.0	0.12	5.6
2.5	0.12	5.72
3.25	0.25	6.61
4.0	0.25	6.61

Efficient pneumatic solutions, our program: cylinders and drives, valves and valve systems, air supply management



Visit us: [Emerson.com/Aventics](https://www.emerson.com/aventics)

Your local contact: [Emerson.com/contactus](https://www.emerson.com/contactus)



[Emerson.com](https://www.emerson.com)



[Facebook.com/EmersonAutomationSolutions](https://www.facebook.com/EmersonAutomationSolutions)



[LinkedIn.com/company/Emerson-Automation-Solutions](https://www.linkedin.com/company/Emerson-Automation-Solutions)



[Twitter.com/EMR_Automation](https://twitter.com/EMR_Automation)

An example configuration is depicted on the title page. The delivered product may thus vary from that in the illustration. Subject to change. This Document, as well as the data, specifications and other information set forth in it, are the exclusive property of AVENTICS GmbH. It may not be reproduced or given to third parties without its consent. Only use the AVENTICS products shown in industrial applications. Read the product documentation completely and carefully before using the product. Observe the applicable regulations and laws of the respective country. When integrating the product into applications, note the system manufacturer's specifications for safe use of the product. The data specified only serve to describe the product. No statements concerning a certain condition or suitability for a certain application can be derived from our information. The information given does not release the user from the obligation of own judgment and verification. It must be remembered that the products are subject to a natural process of wear and aging.

The Emerson logo is a trademark and service mark of Emerson Electric Co. Brand logotype are registered trademarks of one of the Emerson family of companies. All other marks are the property of their respective owners. © 2019 Emerson Electric Co. All rights reserved.



CONSIDER IT SOLVED™