

后耳环



AVENTICS™

AVENTICS 后部铰接元件



后耳环

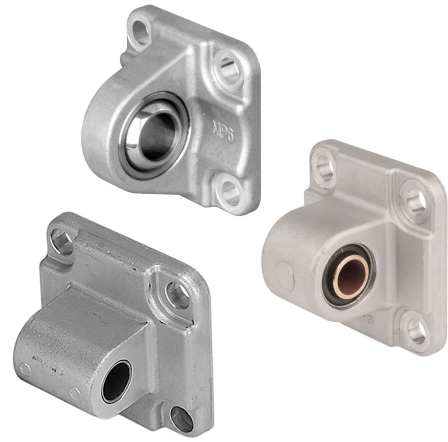

后耳环 MP4-HD, 系列 CM1

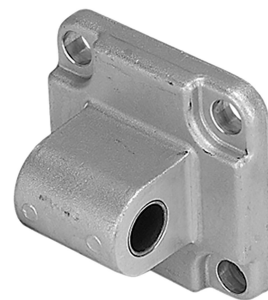

活塞直径 [mm]	万向轴承-Ø [mm]	标准化	材料	物料号
16	6		铝材-压铸件	1825805368
20	8	ISO 21287	钢, 镀铬	1827002300
25	8	ISO 21287	钢, 镀铬	1827002301
32	10	ISO 15552	铝材	1827001283
40	12	ISO 15552	铝材	1827001284
50	12	ISO 15552	铝材	1827001285
63	16	ISO 15552	铝材	1827020086
80	16	ISO 15552	铝材	1827001287
100	20	ISO 15552	铝材	1827001288
125	25	ISO 15552	铝材	1827004866
160	30	ISO 15552	球状石墨铸铁	1827004867
200	30	ISO 15552	球状石墨铸铁	1827004868
250	40	ISO 15552	球状石墨铸铁	1827004869
320	45	ISO 15552	球状石墨铸铁	5239813412

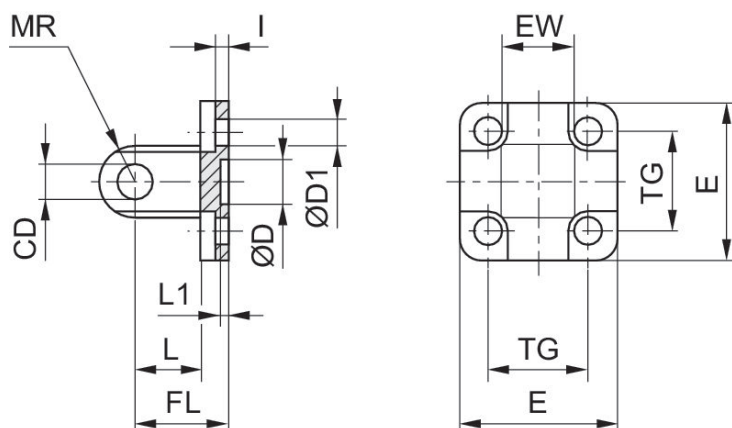

活塞- Ø	物料号	CD H9	Ø D	Ø D1	E	EW	FL ±0,2	I ±0,5	L 最小	L1 最小
16	1825805368	6	10 H13	4.5	27	12 -0.2/-0.6	16	2.6	10	3
20	1827002300	8	12 H13	5.5	34	16 -0.2/-0.6	20	2.6	14	3

活塞- Ø	物料号	CD H9	Ø D	Ø D1	E	EW	FL ±0,2	I ±0,5	L 最小	L1 最小
25	1827002301	8	12 H13	5.5	40	16 -0.2/-0.6	20	2.6	14	3
32	1827001283	10	30 H11	6.6	47.5	26 -0.2/-0.6	22	5.5	12	4.5
40	1827001284	12	35 H11	6.6	53.5	28 -0.2/-0.6	25	5.5	15	4.5
50	1827001285	12	40 H11	9	64	32 -0.2/-0.6	27	6.5	15	4.5
63	1827020086	16	45 H11	9	74	40 -0.2/-0.6	32	6.5	20	4.5
80	1827001287	16	45 H11	11	94	50 -0.2/-0.6	36	10	20	4.5
100	1827001288	20	55 H11	11	113.5	60 -0.2/-0.6	41	10	25	4.5
125	1827004866	25	60 H11	14	138	70 -0.5/-1.2	50	10	30	7
160	1827004867	30	65 H11	18	180	90 -0.5/-1.2	55	10	35	7
200	1827004868	30	75 H11	18	220	90 -0.5/-1.2	60	11	35	7
250	1827004869	40	90 H11	22	280	110 -0.5/-1.2	70	11	45	11
320	5239813412	45	110 H11	26	350	120 -0.5/-1.2	80	15	50	11

活塞- Ø	MR 最大	TG
16	6	18 ±0.2
20	8	22 ±0.4
25	8	26 ±0.4
32	10	32.5 ±0.2
40	12	38 ±0.2
50	12	46.5 ±0.2
63	16	56.5 ±0.2
80	16	72 ±0.2
100	20	89 ±0.2
125	26	110 ±0.3
160	31	140 ±0.3
200	31	175 ±0.3
250	41	220 ±0.3
320	45	270 ±0.3

后耳环 MP4-BV, 系列 CM1

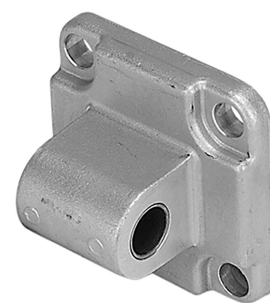

活塞直径 [mm]	万向轴承-Ø [mm]	标准化	材料	物料号
32	10	ISO 15552	铝材-压铸件	R412027408
40	12	ISO 15552	铝材-压铸件	R412027409
50	12	ISO 15552	铝材-压铸件	R412027410
63	16	ISO 15552	铝材-压铸件	R412027411
80	16	ISO 15552	铝材-压铸件	R412027412
100	20	ISO 15552	铝材-压铸件	R412027413

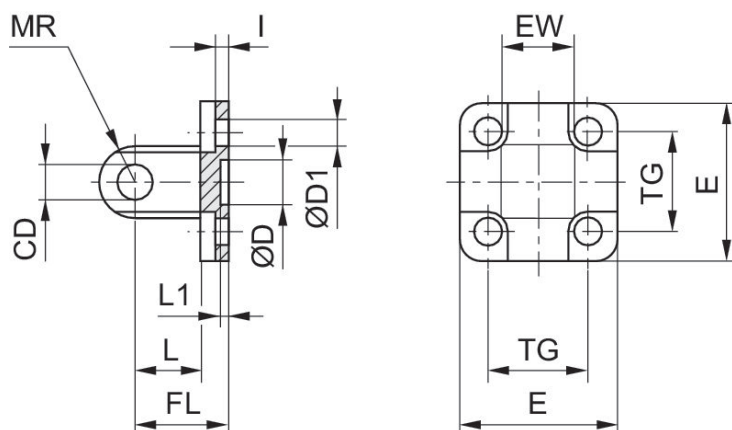

活塞- Ø	物料号	CD H9	Ø D	Ø D1	E	EW	FL ±0,2	I ±0,5	L 最小	L1 最小
32	R412027408	10	30 H11	6.6	45	26	22	5.5	13	5
40	R412027409	12	35 H11	6.6	52	28	25	5.5	16	5
50	R412027410	12	40 H11	9	65	32	27	6.5	16	4.5
63	R412027411	16	45 H11	9	75	40	32	6.5	21	4.5
80	R412027412	16	45 H11	11	95	50	36	10	22	4.5
100	R412027413	20	55 H11	11	115	60	41	10	27	4.5

活塞- Ø	MR 最大	TG
32	10	32,5
40	12	38
50	12	46,5

活塞- Ø	MR 最大	TG
63	16	56,5
80	16	72
100	20	89

后耳环 MP6, 系列 CM1

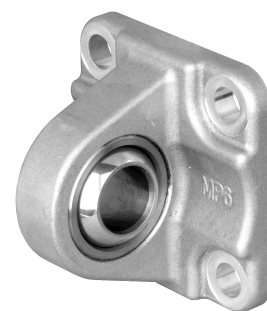

活塞直径 [mm]	万向轴承-Ø [mm]	标准化	材料	物料号
25	10	ISO 21287	铝材	3663602000
32	10	ISO 6431	铝材	3663603000
40	12	ISO 6431	铝材	3663604000
50	12	ISO 6431	铝材	3663605000
52.5	10		铝材	5220163442
63	16	ISO 6431	铝材	3663606000
75	12		铝材	5220363442
80	16	ISO 6431	铝材	3663608000
85, 95	16		铝材	5220463442
100	20	ISO 6431	铝材	3663610000
115	16		铝材	5220563442

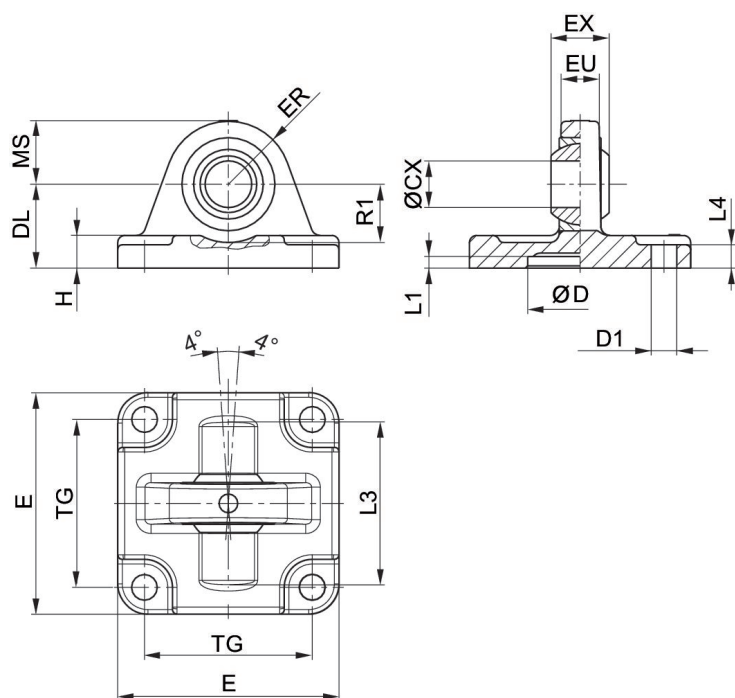

供货内容范围：对接轴承包括固定螺栓

活塞- Ø	物料号	ØCX H7	ØD H11	ØD1 H13	DL ±0,2	E	EX -0,1	ER	EU	H
25	3663602000	10	18	5,5	20	40	9	14	8	6
32	3663603000	10	20	5,5	22	46	9	15	8	6
40	3663604000	12	30	6,6	28	55	12	17	9,5	8
52,5	3663605000	12	40	6,6	28	62	12	17	9,5	9
63	5220163442	10	-	7,5	29	45	14	15	10,5	8
75	3663606000	16	55	9	36	80	16	25	12,5	11
80	5220363442	12	-	10	26	65	16	18	12	10
80	3663608000	16	70	9	38	94	16	28	12,5	12
85, 95	5220463442	16	-	10	30	75	21	22	15	10
100	3663610000	20	90	11	43	114	20	35	16	15
115	5220563442	16	-	12	37,5	95	21	25	15	12

活塞- Ø	L1 最小	L3	L4	MS -0,5	R1 最小	TG
25	3	-	3	14	-	26
32	0,5	42	6	15	16	32
40	0,5	48	8	17	16	32
52,5	0,5	55	9	17	18	46
63	-	-	-	-	-	33
75	0,5	70	11	25	21	59
80	-	-	-	-	-	49
80	0,5	80	12	28	21	73
85, 95	-	-	-	-	-	59
100	0,5	100	15	35	28	90
115	-	-	-	-	-	75

后耳环 MP6, 系列 CM1

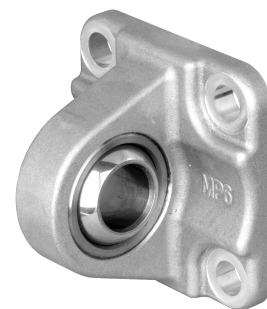

活塞直径 [mm]	万向轴承-Ø [mm]	标准化	材料	物料号
32	10	ISO 15552	铝 (已锻造)	1827001619
40	12	ISO 15552	铝 (已锻造)	1827001620
50	16	ISO 15552	铝 (已锻造)	1827001621
63	16	ISO 15552	铝 (已锻造)	1827020087
80	20	ISO 15552	铝 (已锻造)	1827001623
100	20	ISO 15552	铝 (已锻造)	1827001624
125	30	ISO 15552	铝 (已锻造)	1827001625

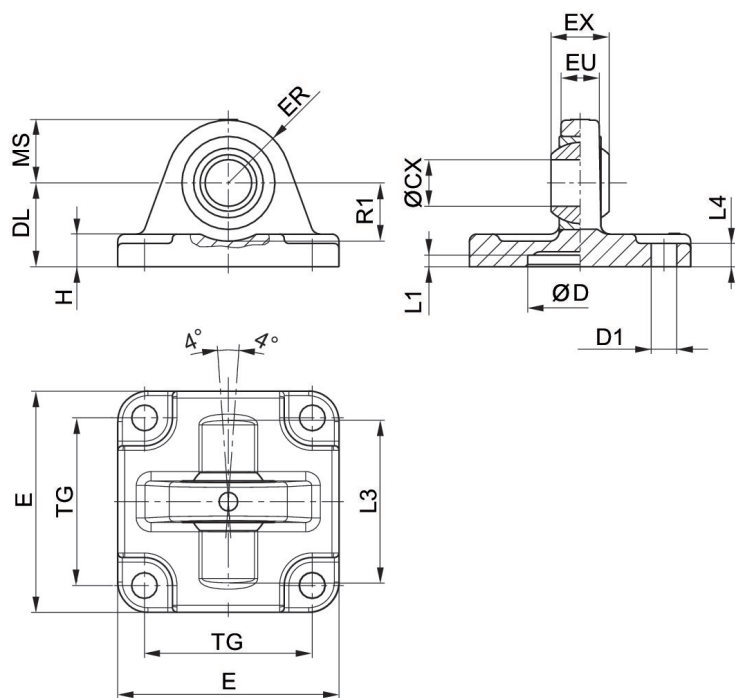

供货内容范围：对接轴承包括固定螺栓

活塞- Ø	物料号	ØCX H7	ØD H11	ØD1 H13	DL ±0,2	E	EX -0,1	ER	EU	H
32	1827001619	10	30	6.6	22	47	14	15	10.5	9
40	1827001620	12	35	6.6	25	53	16	18	12	9

活塞- Ø	物料号	ØCX H7	ØD H11	ØD1 H13	DL ±0,2	E	EX -0,1	ER	EU	H
50	1827001621	16	40	9	27	65	21	20	15	10.5
63	1827020087	16	45	9	32	75	21	23	15	10.5
80	1827001623	20	45	11	36	95	25	27	18	14
100	1827001624	20	55	11	41	115	25	30	18	15
125	1827001625	30	60	14	50	140	37	40	25	16

活塞- Ø	L1 最小	L3	L4	MS -0,5	R1 最小	TG
32	4.5	36	5.5	15	12	32,5 ±0,2
40	4.5	42	5.5	18	15	38 ±0,2
50	4.5	48	6.5	21	19	46,5 ±0,2
63	4.5	55	6.5	23	21	56,5 ±0,2
80	4.5	70	10	27	24	72 ±0,2
100	4.5	80	10	30	25	89 ±0,2
125	7	100	10	40	33	110 ±0,3

后耳环 MP6, 系列 CM1

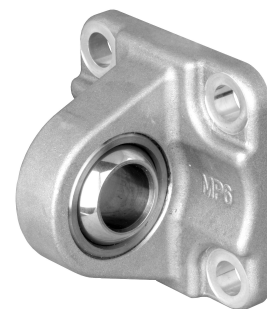

活塞直径 [mm]	万向轴承-Ø [mm]	标准化	材料	物料号
32	10	ISO 15552	铝 (已锻造并阳极氧化处理)	2798060320
40	12	ISO 15552	铝 (已锻造并阳极氧化处理)	2798060400
50	16	ISO 15552	铝 (已锻造并阳极氧化处理)	R412025637
50	12		铝 (已锻造并阳极氧化处理)	2798060500
63	16	ISO 15552	铝 (已锻造并阳极氧化处理)	2798060630
80	20	ISO 15552	铝 (已锻造并阳极氧化处理)	R412025638
80	16		铝 (已锻造并阳极氧化处理)	2798060800
100	20	ISO 15552	铝 (已锻造并阳极氧化处理)	2798061000
125	30	ISO 15552	铝 (已锻造并阳极氧化处理)	R412025572

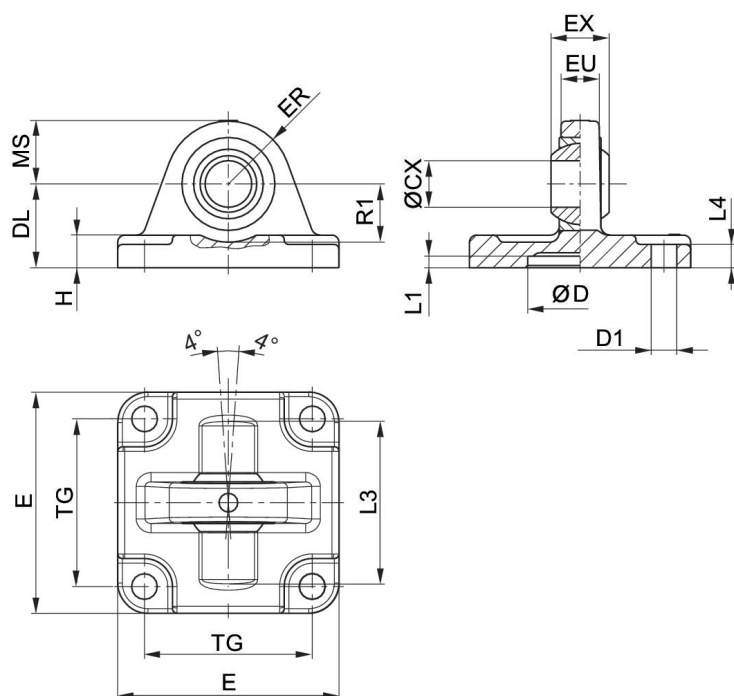

供货内容范围：对接轴承包括固定螺栓

物料号	活塞- Ø	ØCX H7	ØD H11	ØD1 H13	DL ±0,2	E	EX -0,1	ER	EU	H
2798060320	32	10	30	6,6	22	46	14	17	12,5	6.5
2798060400	40	12	35	6,6	25	52	16	20	12	8
2798060500	50	12	40	9	25	62	16	22	14	9
R412025637	50	16	40	9	27	64	21	22	14	9
2798060630	63	16	45	9	32	74	21	25	15	11
2798060800	80	16	45	11	36	94	21	30	17	12
R412025638	80	20	45	11	36	94	25	30	17	12
2798061000	100	20	55	11	41	114	25	32	20	15
R412025572	125	30	60	13.5	50	138	37	-	25	-

物料号	活塞- Ø	L1 最小	L3	L4	MS -0,5	R1 最小	TG
2798060320	32	4.5	-	5,5	15,5	16,5	32,5
2798060400	40	4.5	-	5,5	18	19,5	38
2798060500	50	5	46,5	6,5	24	18,5	46,5
R412025637	50	4.5	48	6.5	21	19	46,5
2798060630	63	4,5	-	6,5	23	25,5	56,5
2798060800	80	4,5	-	10	30	26	72
R412025638	80	4.5	70	10	28	24	72
2798061000	100	4,5	-	10	30	31	89
R412025572	125	7	-	10	40	32	110 ±0,3

后耳环 MP6, 系列 CM1

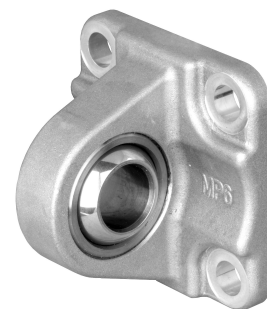

活塞直径 [mm]	万向轴承-Ø [mm]	标准化	材料	物料号
160	35	ISO 15552	球状石墨铸铁	1827001626
200	35	ISO 15552	球状石墨铸铁	1827001627
250	40	ISO 15552	球状石墨铸铁	1827001628
320	50	ISO 15552	球状石墨铸铁	5239013452

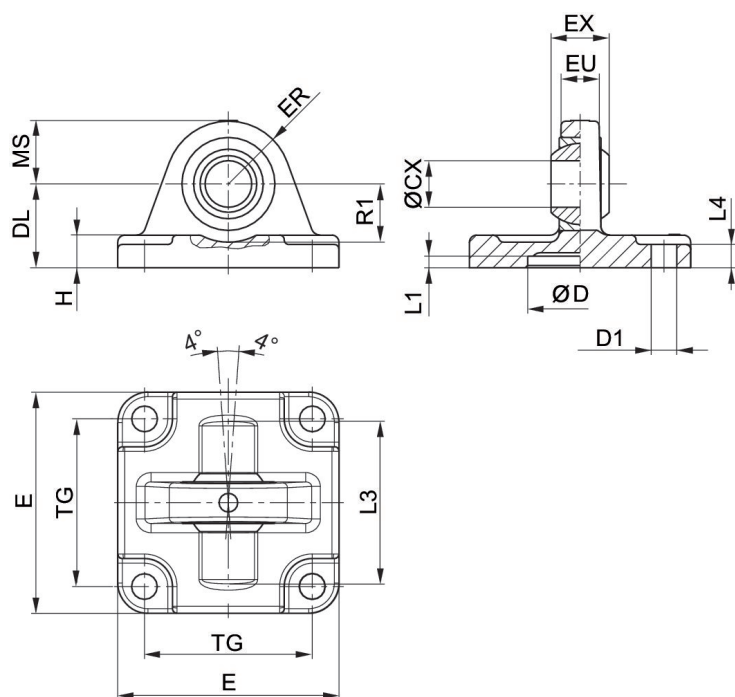

供货内容范围：对接轴承包括固定螺栓

活塞- Ø	物料号	ØCX H7	ØD H11	ØD1 H13	DL ±0,2	E	EX -0,1	ER	EU	H
160	1827001626	35	65	18	55	176	43	44	30	17
200	1827001627	35	75	18	60	216	43	47	30	19.5
250	1827001628	40	90	22	70	275	49	53	35	22
320	5239013452	50	110	26	80	340	60	63	45	27

活塞- Ø	L1 最小	L3	L4	MS -0,5	R1 最小	TG
160	7	130	10	44	39	140 ±0,3
200	7	130	11	47	41	175 ±0,3
250	11	-	11	53	45	220 ±0,3
320	11	180	15	63	55	270 ±0,3

后耳环 MP9, 系列 CM1



活塞直径 [mm]	万向轴承-Ø [mm]	标准化	材料	物料号
32	10	ISO 15552	铝材	3683203000
50	12	ISO 15552	铝材	3683205000
80	16	ISO 15552	铝材	3683208000
50	12		铝材	3663205000
80	16		铝材	3663208000
125	25	ISO 15552	铝材	R412015973

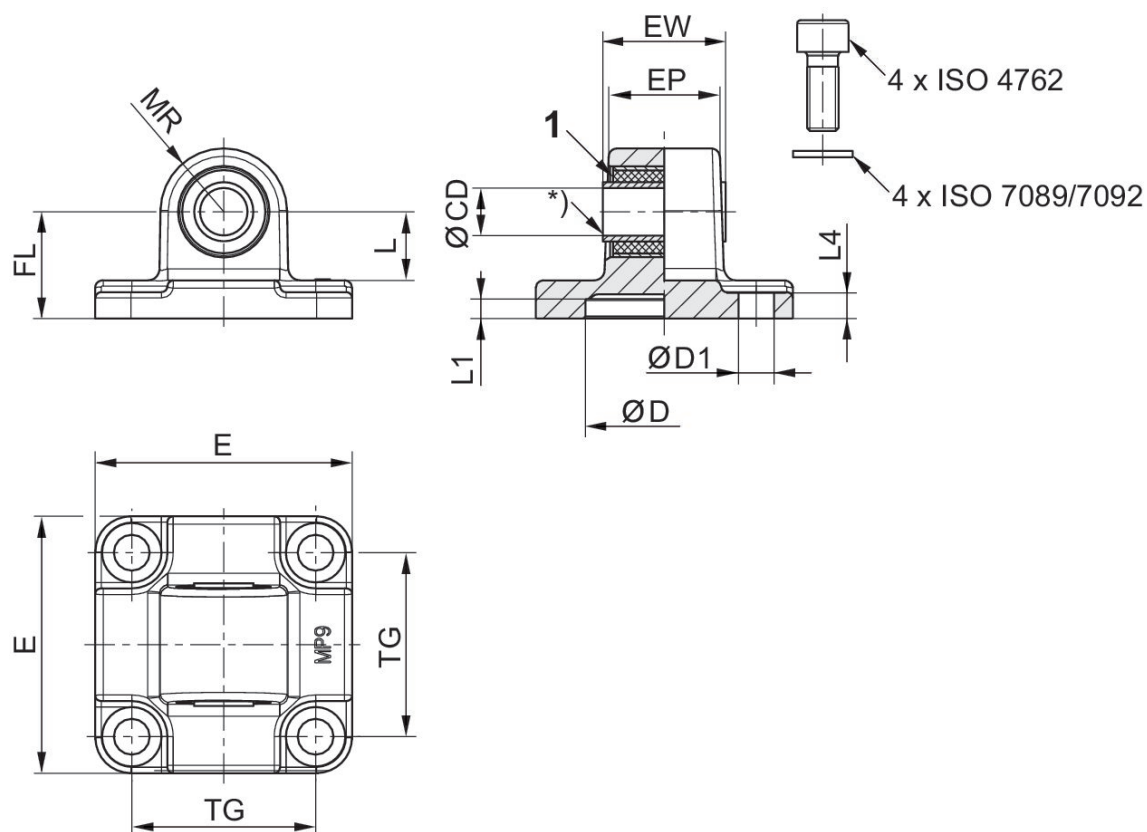

1) 橡胶衬套

活塞- Ø	物料号	CD H11	CD H9	E	EW	EP	TG	TG1 ±0,2	FL ±0,2	L 1)
32	3683203000	10	-	46	25.5	18,9	32.5	-	22	13.8
50	3683205000	-	12	65	31	28	46.5	-	27	17.3
50	3663205000		12	63	31		46		28	15.5
80	3663208000		16	95	49.5		73		38	20.5
80	3683208000	-	16	94.5	49.5	43	72	-	36	21.8
125	R412015973	-	25	138	69.5	60	110	-	50	33.8

活塞- Ø	MR	L1	L4	D H11	D1 H13
32	12.5	5	5.5	30	6.6
50	16	5	6.5	40	9
50	18				
80	24				
80	22	5	10	45	11
125	34	7.5	10	60	13.5

后耳环 MP9, 系列 CM1



活塞直径 [mm]	万向轴承-Ø [mm]	标准化	材料	物料号
25	10	ISO 21287	铝材-压铸件	3683202000
40	12	ISO 15552	铝材	3683204000
63	16	ISO 15552	铝材	3683206000
100	20	ISO 15552	铝材	3683210000

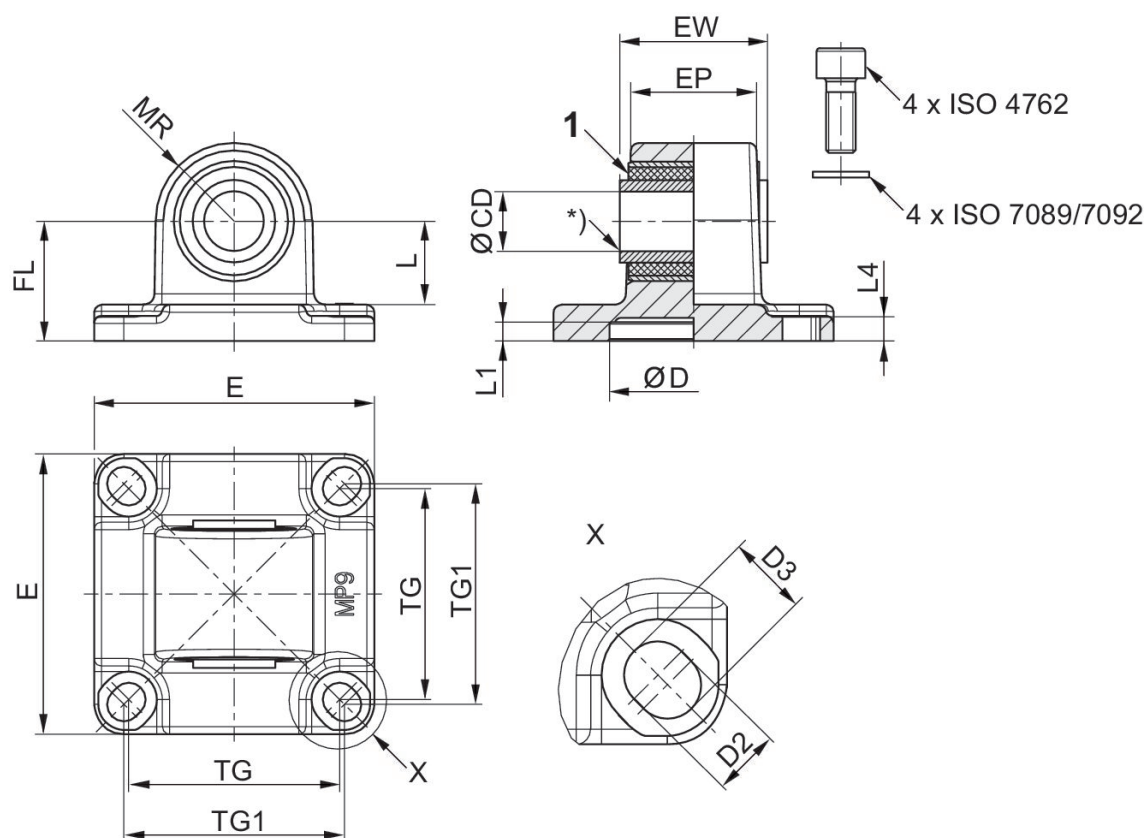

1) 橡胶衬套

活塞- Ø	物料号	CD H11	CD H9	E	EW	EP	TG	TG1 ±0,2	FL ±0,2	L 1)
25	3683202000	10	-	40	17,5	14,5	26	27	20	14.8
40	3683204000	-	12	53	27	23,5	38	40	25	16.3

活塞- Ø	物料号	CD H11	CD H9	E	EW	EP	TG	TG1 ±0,2	FL ±0,2	L 1)
63	3683206000	-	16	75	39.5	33.5	56.5	59	32	22.3
100	3683210000	-	20	114	59.5	54	89	90	41	25.8

活塞- Ø	MR	L1	L4	D H11	D2 -0,2	D3 -0,2
25	12,5	3	3	18	5,5	6,2
40	15	5	5.5	35	6.6	8
63	21	5	6.5	45	-	-
100	25	5	10	55	11	11.7

后耳环

CNOMO / NFE 49-001



活塞直径 [mm]	万向轴承-Ø [mm]	标准化	材料	物料号
25, 32	8	CNOMO / NFE 49-001	铝材	R422003607
40, 50	12	CNOMO / NFE 49-001	铝材	R422003608
63, 80	16	CNOMO / NFE 49-001	铝材	R422003609
100, 125	20	CNOMO / NFE 49-001	铝材	R422003610
160, 200	25	CNOMO / NFE 49-001	铝材	R422003611

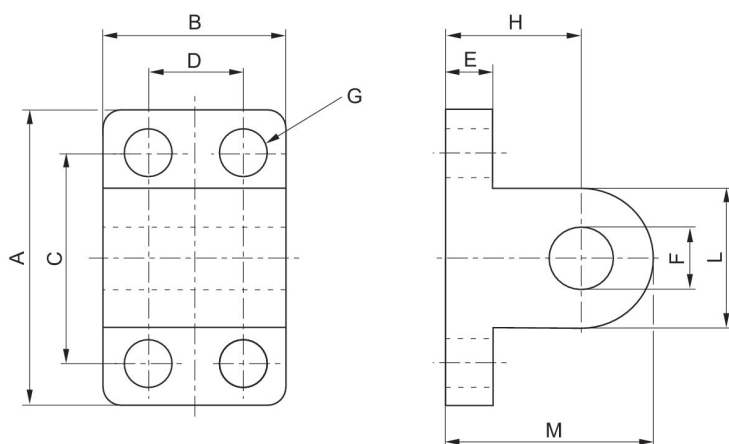

活塞- Ø	物料号	A	B	C	D	E	F H9	G	H	L 1)
25, 32	R422003607	40	25	28	-	8	8	7	18	16
40, 50	R422003608	52	32	38	16	10	12	9	26	24
63, 80	R422003609	75	46	54	25	12	16	11	34	36
100,125	R422003610	115	56	90	32	16	20	14	41	40
160, 200	R422003611	180	71	150	43	20	25	18	55	50

活塞- Ø	M 1)
25, 32	26
40, 50	38
63, 80	52
100,125	61
160, 200	80

1) 最大值.

带螺栓的支座

CNOMO / NFE 49-001



活塞直径 [mm]	标准化	材料	物料号
32	CNOMO / NFE 49-001	铝材	5210163472
40	CNOMO / NFE 49-001	铝材	5210263472
50	CNOMO / NFE 49-001	铝材	5210363472
63	CNOMO / NFE 49-001	铝材	5210463472
80	CNOMO / NFE 49-001	铝材	5210563472
100	CNOMO / NFE 49-001	铝材	5210663472
125	CNOMO / NFE 49-001	铝材	5210763472

支座规格

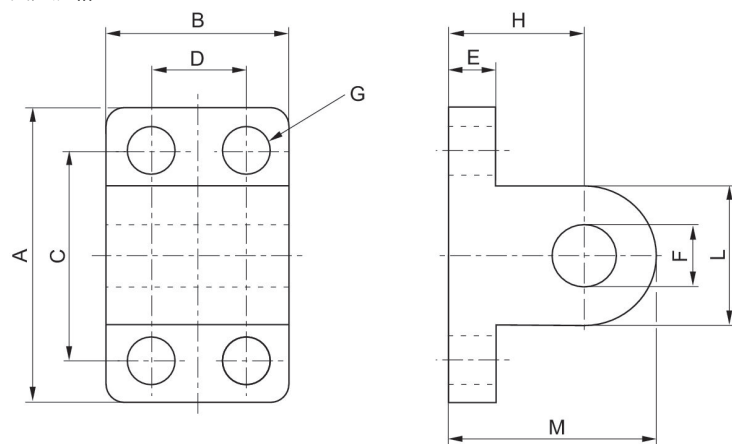

活塞- Ø	A	B	C	D	E	F H9	G	H	L 1)	M 1)
32	40	25	28	-	8	8	7	18	16	26
40	52	32	38	16	10	12	9	26	24	38
50	52	32	38	16	10	12	9	26	24	38
63	75	46	54	25	12	16	11	34	36	52
80	75	46	54	25	12	16	11	34	36	52
100	115	56	90	32	16	20	14	41	40	61
125	115	56	90	32	16	20	14	41	40	61

活塞- Ø	BT	BU	CG	CH	G f7
32	46	53	7.6	1.1	8
40	53	60	11.5	1.1	12
50	66	73	11.5	1.1	12
63	76	83	15.2	1.1	16
80	96	103	15.2	1.1	16
100	117	124	19	1.3	20
125	142	149	19	1.3	20

1) 最大

后耳环, 系列 MP4

NFPA



活塞直径 [mm]	标准化	材料	物料号
38.1	NFPA	铝材	R432013369
50.8	NFPA	铝材	R432012549
63.5	NFPA	铝材	R432013377
82.55	NFPA	铝材	R432013392
101.6	NFPA	铝材	R432013400

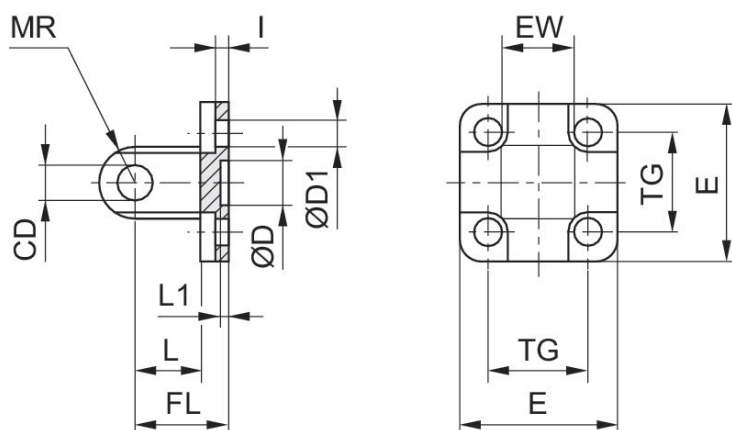

尺寸按英寸

Ø	物料号	CD H9	Ø D	Ø D1	E	EW	FL	L	L1	MR
1.5	R432013369	0.500	-	-	2.00	0.75	1.13	0.75	-	0.53
2.0	R432012549	0.500	-	-	2.50	0.75	1.13	0.75	-	0.53
2.5	R432013377	0.500	-	-	3.00	0.75	1.13	0.75	-	0.53
3.25	R432013392	0.750	-	-	3.75	1.25	1.88	1.25	-	0.78
4.0	R432013400	0.750	-	-	4.50	1.25	1.88	1.25	-	0.78

Ø	TG
1.5	-
2.0	-
2.5	-
3.25	-

∅	TG
4.0	-

后耳环, 系列 MP4-HD

ISO 15552

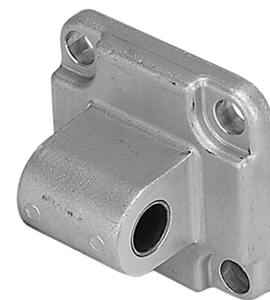

活塞直径 [mm]	万向轴承-Ø [mm]	标准化	材料	物料号
32	10	ISO 15552	铝材	R412027813
40	12	ISO 15552	铝材	R412027814
50	12	ISO 15552	铝材	R412027815
63	16	ISO 15552	铝材	R412027816
80	16	ISO 15552	铝材	R412027817
100	20	ISO 15552	铝材	R412027818
125	25	ISO 15552	铝材	R412027819

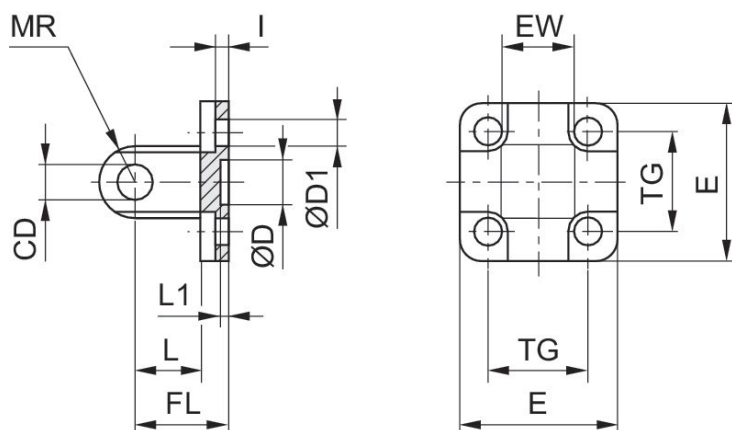

活塞- Ø	物料号	CD H9	Ø D	Ø D1	E	EW	FL ±0.2	I ±0.5	L 最小	L1 最小
32	R412027813	10	30 H11	6.6	47.5	26 -0.2/-0.6	22	5.5	12	4.5
40	R412027814	12	35 H11	6.6	53.5	28 -0.2/-0.6	25	5.5	15	4.5
50	R412027815	12	40 H11	9	64	32 -0.2/-0.6	27	6.5	15	4.5
63	R412027816	16	45 H11	9	74	40 -0.2/-0.6	32	6.5	20	4.5
80	R412027817	16	45 H11	11	94	50 -0.2/-0.6	36	10	20	4.5
100	R412027818	20	55 H11	11	113.5	60 -0.2/-0.6	41	10	25	4.5
125	R412027819	25	60 H11	14	138	70 -0.2/-0.6	50	10	30	7

活塞- Ø	MR 最大	TG
32	10	32.5 ±0.2

活塞- Ø	MR 最大	TG
40	12	38 ±0.2
50	12	46.5 ±0.2
63	16	56.5 ±0.2
80	16	72 ±0.2
100	20	89 ±0.2
125	26	110 ±0.3

轴承支座

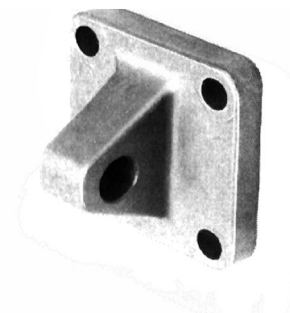

活塞直径 [mm]	材料	物料号
38.1	铝材	R432013368
50.8	铝材	R432012551
63.5	铝材	R432013376
82.55	铝材	R432008890
101.6	铝材	R432008892

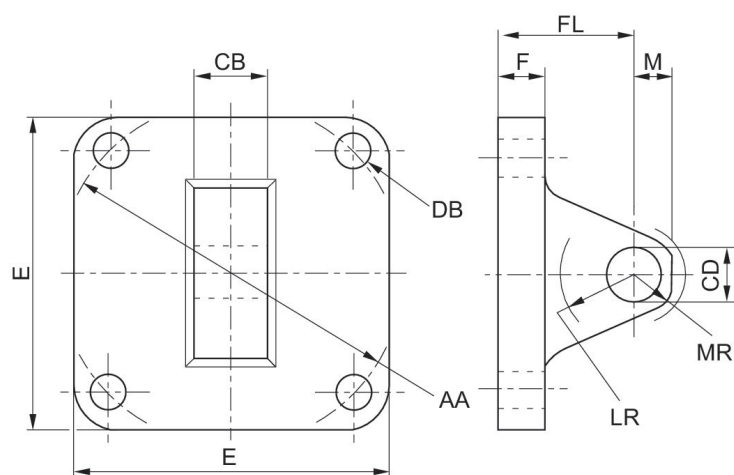

尺寸按英寸

Ø	物料号	E	F	M	AA	CB	CD	DB	FL	LR
1.50	R432013368	2.00	0.38	0.50	2.02	0.75	0.50	0.25	1.13	0.63
2.00	R432012551	2.50	0.38	0.50	2.60	0.75	0.50	0.31	1.13	0.63
2.50	R432013376	3.00	0.38	0.50	3.10	0.75	0.50	0.31	1.13	0.63
3.25	R432008890	3.75	0.63	0.75	3.90	1.25	0.75	0.38	1.88	0.88
4.00	R432008892	4.504	0.63	0.75	4.70	1.25	0.75	0.38	1.88	0.88

Ø	MR
1.50	0.53
2.00	0.53
2.50	0.53

\varnothing	MR
3.25	0.78
4.00	0.78

Efficient pneumatic solutions, our program: cylinders and drives, valves and valve systems, air supply management



Visit us: [Emerson.com/Aventics](https://www.emerson.com/Aventics)

Your local contact: [Emerson.com/contactus](https://www.emerson.com/contactus)



[Emerson.com](https://www.emerson.com)



[Facebook.com/EmersonAutomationSolutions](https://www.facebook.com/EmersonAutomationSolutions)



[LinkedIn.com/company/Emerson-Automation-Solutions](https://www.linkedin.com/company/Emerson-Automation-Solutions)



[Twitter.com/EMR_Automation](https://twitter.com/EMR_Automation)

An example configuration is depicted on the title page. The delivered product may thus vary from that in the illustration. Subject to change. This Document, as well as the data, specifications and other information set forth in it, are the exclusive property of AVENTICS GmbH. It may not be reproduced or given to third parties without its consent. Only use the AVENTICS products shown in industrial applications. Read the product documentation completely and carefully before using the product. Observe the applicable regulations and laws of the respective country. When integrating the product into applications, note the system manufacturer's specifications for safe use of the product. The data specified only serve to describe the product. No statements concerning a certain condition or suitability for a certain application can be derived from our information. The information given does not release the user from the obligation of own judgment and verification. It must be remembered that the products are subject to a natural process of wear and aging.

The Emerson logo is a trademark and service mark of Emerson Electric Co. Brand logotype are registered trademarks of one of the Emerson family of companies. All other marks are the property of their respective owners. © 2019 Emerson Electric Co. All rights reserved.



CONSIDER IT SOLVED™