

Fijaciones por brida

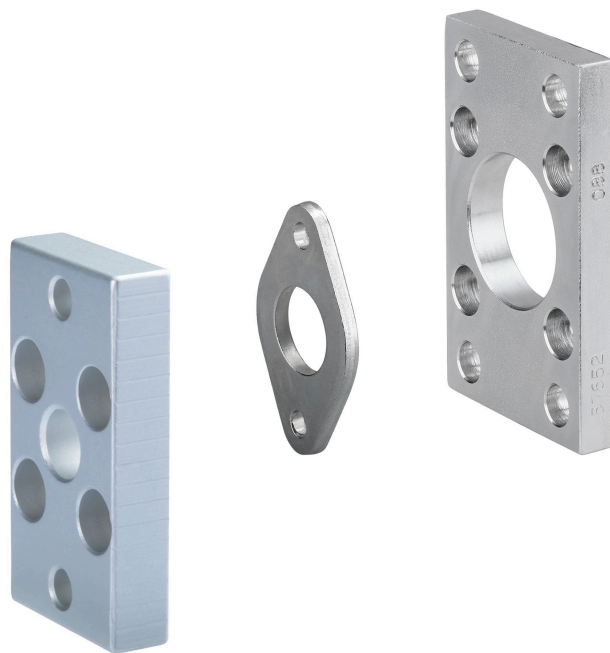

Fijación por brida

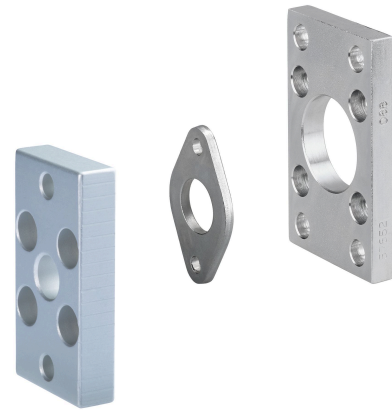

Fijación por brida MF1, MF2, Serie CM1

ISO 15552



Diámetro de émbolo [mm]	Normalización	Material	N° de material
32	ISO 15552	Acero, cromado	1827001277
40	ISO 15552	Acero, cromado	1827001278
50	ISO 15552	Acero, cromado	1827001279
63	ISO 15552	Acero, cromado	1827001499
80	ISO 15552	Acero, cromado	1827001281
100	ISO 15552	Acero, cromado	1827001282
125	ISO 15552	Acero, cromado	1827004861
160	ISO 15552	Acero, cromado	1827001460
200	ISO 15552	Acero, cromado	1827001461
250	ISO 15552	Acero, cromado	1827001462
320	ISO 15552	Acero, cromado	5239016012

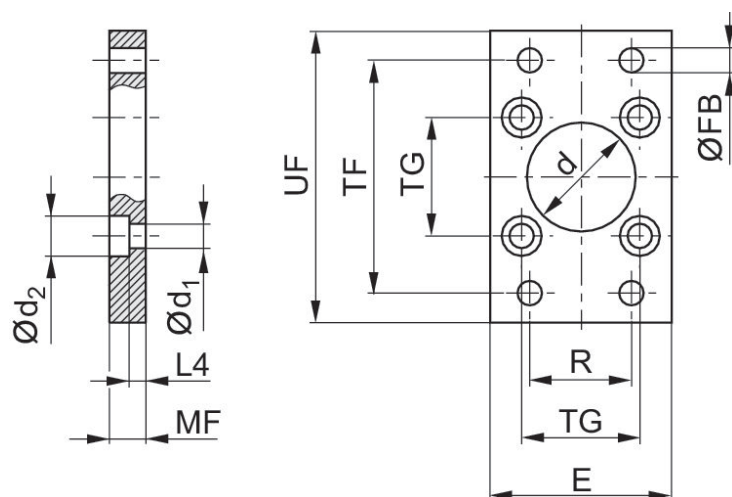

Ø del émbolo	N° de material	Ød H11	Ød1	Ød2	E máx.	ØFB	L4	MF	R	TF
32	1827001277	30	6.6	11	50	7	4.5	10	32	64
40	1827001278	35	6.6	11	55	9	4.5	10	36	72
50	1827001279	40	9	15	65	9	6	12	45	90
63	1827001499	45	9	15	75	9	6	12	50	100

Ø del émbolo	N° de material	Ød H11	Ød1	Ød2	E máx.	ØFB	L4	MF	R	TF
80	1827001281	45	11	18	100	12	9	16	63	126
100	1827001282	55	11	18	120	14	9	16	75	150
125	1827004861	60	14	20	140	16	10.5	20	90	180
160	1827001460	65	18	26	180	18	9.5	20	115	230
200	1827001461	75	18	26	220	22	12.5	25	135	270
250	1827001462	90	22	33	280	26	10.5	25	165	330
320	5239016012	110	26	40	350	33	15	30	200	270

Ø del émbolo	TG	UF
32	32,5 ±0,2	80
40	38 ±0,2	90
50	46,5 ±0,2	110
63	56,5 ±0,2	125
80	72 ±0,2	154
100	89 ±0,2	186
125	110 ±0,3	220
160	140 ±0,3	275
200	175 ±0,3	312
250	220 ±0,3	380
320	270 ±0,3	400

Fijación por brida MF1, MF2, Serie CM1



Diámetro de émbolo [mm]	Material	N° de material
16	Acero, cromado	1821038241
20	Acero, cromado	1827002292
25	Acero, cromado	1827002293

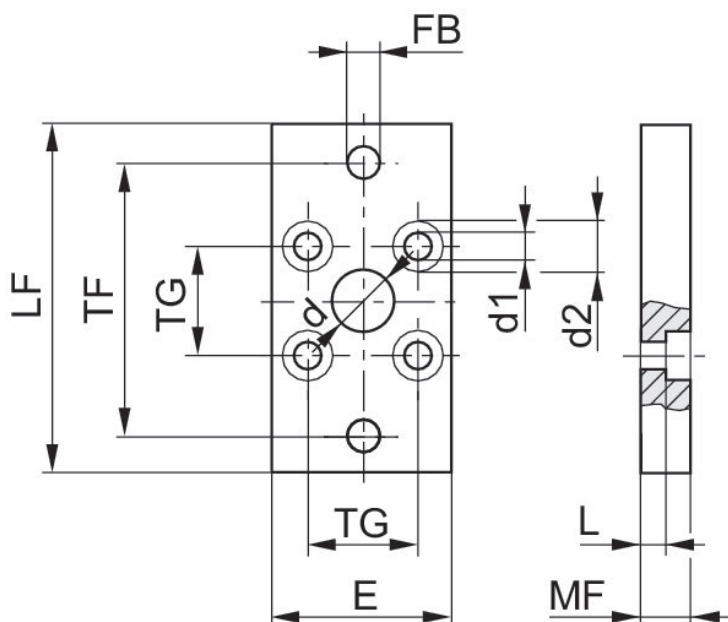

Ø del émbolo	N° de material	Ød H11	Ød1	Ød2	E 1)	ØFB	L4	MF	TF	TG
16	1821038241	10	4.5	10	29	5.5	5.6	10	43	18
20	1827002292	12	5.5	10	36	6.6	4.6	10	55	22
25	1827002293	12	5.5	10	40	6.6	4.6	10	60	26

Ø del émbolo	UF
16	55
20	70
25	76

1) Máx.

Fijación por brida MF1, MF2, Serie CM1



Diámetro de émbolo [mm]	Material	N° de material
32	Acero, cromado	1827002294
40	Acero, cromado	1827002295
50	Acero, cromado	1827002296
63	Acero, cromado	1827002297
80	Acero, cromado	1827002298
100	Acero, cromado	1827002299

Dimensiones

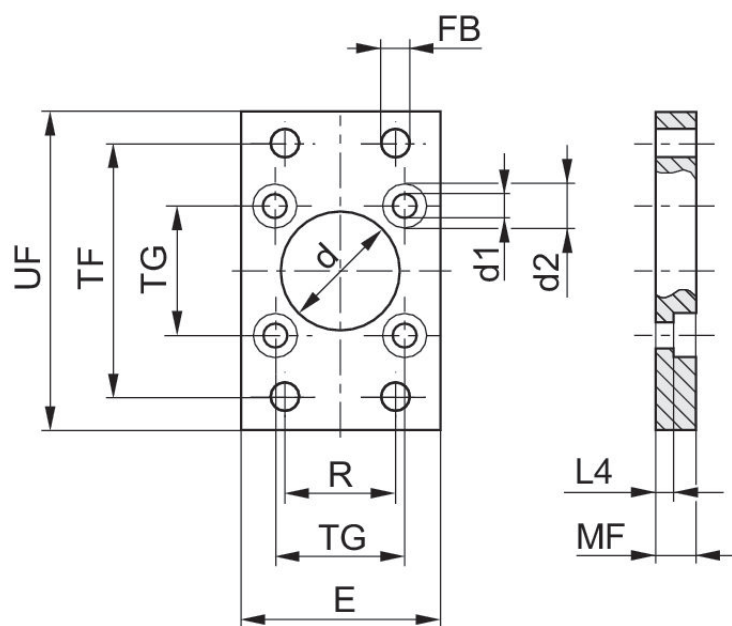

Ø del émbolo	N° de material	Ød H11	Ød1	Ød2	E 1)	ØFB	L4	MF	R	TF
32	1827002294	14	6.6	11	50	7	3.6	10	32	65
40	1827002295	14	6.6	11	60	9	3.6	10	36	82
50	1827002296	18	9	15	66	9	3.4	12	45	90
63	1827002297	18	9	15	87	9	6.4	15	50	110
80	1827002298	23	11	18	107	12	4.4	15	63	135

Ø del émbolo	N° de material	Ød H11	Ød1	Ød2	E 1)	ØFB	L4	MF	R	TF
100	1827002299	28	11	18	128	14	4.4	15	75	163

Ø del émbolo	TG	UF
32	32	80
40	42	102
50	50	110
63	62	130
80	82	160
100	103	190

1) Máx.

Fijación por brida MF8, Serie CM1

ISO 6432



Diámetro de émbolo [mm]	Normalización	Material	N° de material
8, 10	ISO 6432	acero galvanizado	1821036012
12, 16	ISO 6432	acero galvanizado	1821036011
20, 25	ISO 6432	acero galvanizado	1821036010
8, 10	ISO 6432	Acero inoxidable	3322010000
12, 16	ISO 6432	Acero inoxidable	3322016000
20, 25	ISO 6432	Acero inoxidable	3322020000

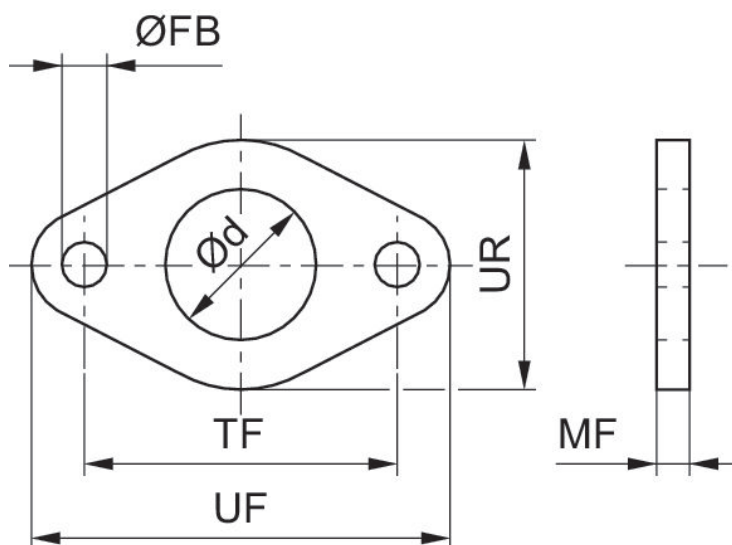

Ø del émbolo	N° de material	Ø d	Ø FB	MF	TF js14	UF	UR
8, 10	3322010000	12	4.5	3	30	40	22
12, 16	3322016000	16	5.5	4	40	52	30
20, 25	3322020000	22	6.6	5	50	66	40
8, 10	1821036012	12	4.5	3	30	40	25
12, 16	1821036011	16	5.5	4	40	52	30
20, 25	1821036010	22	6.6	5	50	66	40

Fijación por brida, Serie MF1, MF2

CNOMO / NFE 49-001



Diámetro de émbolo [mm]	Cojinete de articulación-Ø [mm]	Material	N° de material
25		Acero, cromado	1827005926
32	30	Acero, cromado	1827005927
40	30	Acero, cromado	1827005928
50	30	Acero, cromado	1827005929
63	30	Acero, cromado	1827005930
80	30	Acero, cromado	1827005931
100	30	Acero, cromado	1827005932
125	30	Acero, cromado	1827005933
160	30	Acero, cromado	7472ZZ1408
200	30	Acero, cromado	7472ZZ1409

Dimensiones

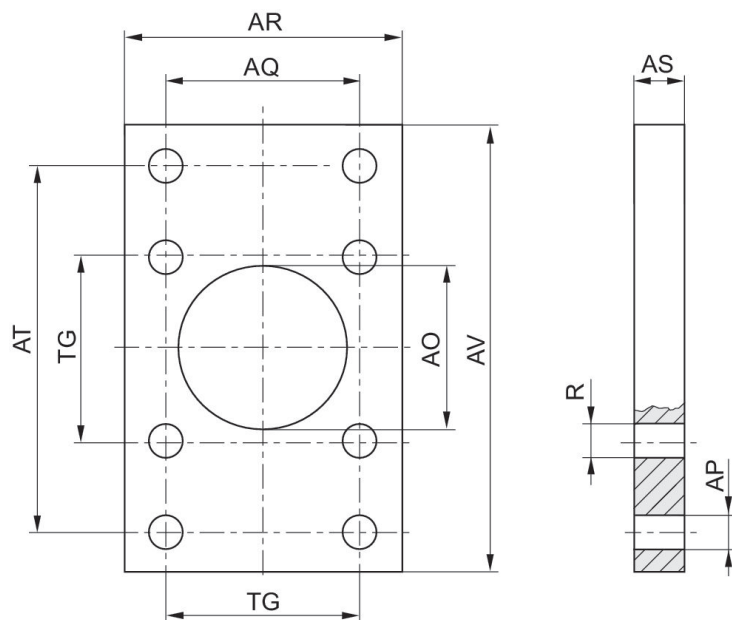

Ø del émbolo	N° de material	AO H11	AP H13	AQ JS14	AR	AS	AT JS14	AV	R	TG
25	1827005926	25	9	28	40	8	68	80	7	28

Ø del émbolo	N° de material	AO H11	AP H13	AQ JS14	AR	AS	AT JS14	AV	R	TG
32	1827005927	25	9	33	45	8	68	80	7	33
40	1827005928	32	9	40	52	8	78	90	7	40
50	1827005929	32	11	49	65	10	94	110	9	49
63	1827005930	45	11	59	75	10	104	120	9	59
80	1827005931	45	14	75	95	12	130	150	11	75
100	1827005932	55	14	90	115	12	150	170	11	90
125	1827005933	55	18	110	140	16	180	205	14	110
160	7472ZZ1408	65	22	140	180	20	228	260	18	140
200	7472ZZ1409	65	22	175	220	20	268	300	18	175

Fijación por brida



Material	N° de material
Acero, cromado	R412010333
Acero, cromado	R412010334

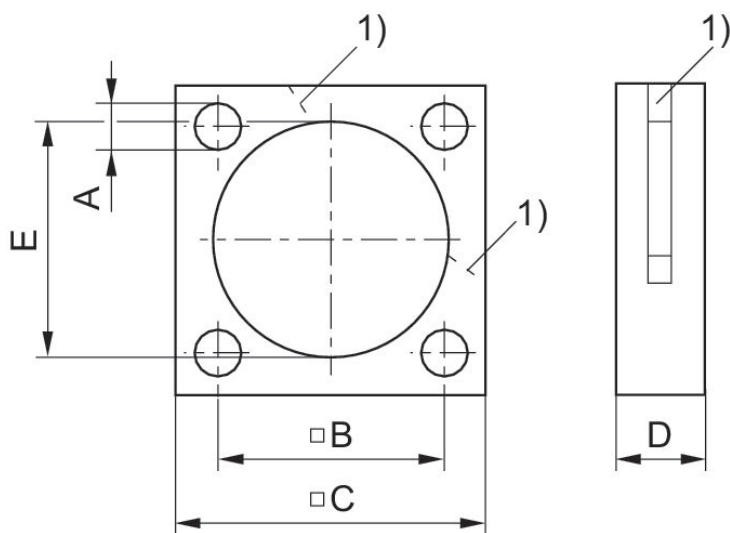

1) ranura de apriete

N° de material	A	B	C	D	E
R412010333	6.6	32	45	12	M33x1,5
R412010334	11	58	80	16	M64x2

Brida de apriete



N° de material
R412010341
R412010342

Dimensiones

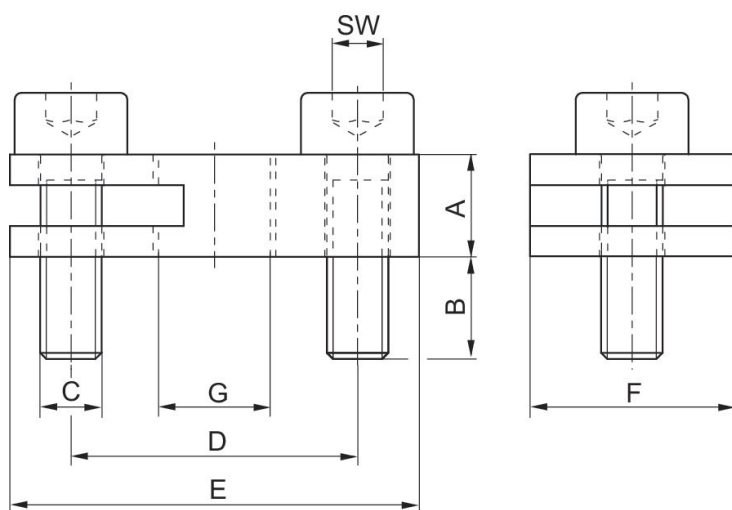

N° de material	A	B	C	D	E	F	G	SW
R412010341	5	5	M3x10	14	20	10	M6x0,5	2,5
R412010342	6	6	M4x12	18	25	15	M8x1	3

Brida de apriete



N° de material
R412010343
R412010344
R412010345
R412010346
R412010347

Dimensiones

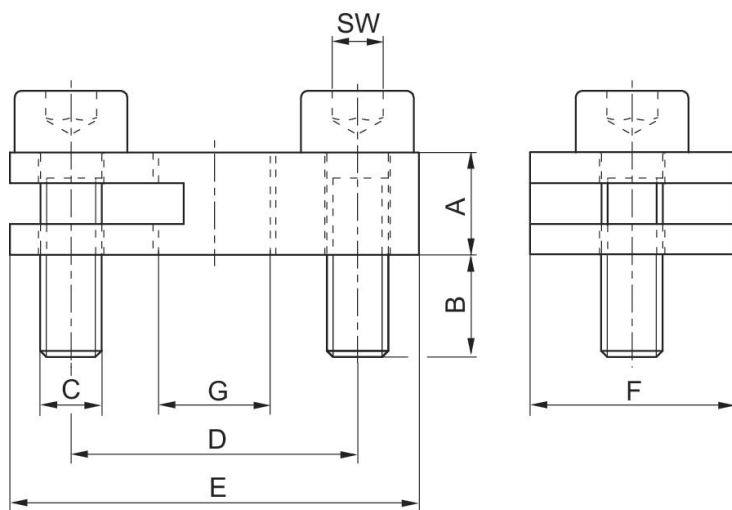

N° de material	A	B	C	D	E	F	G	H	SW
R412010343	14	6	M4x20	16	25	10	M10x1	2	3
R412010344	16	8	M5x20	20	32	12	M12x1	2	4
R412010345	20	10	M5x25	20	32	12	M14x1,5	2	4
R412010346	25	11	M6x30	28	40	20	M20x1,5	2	5
R412010347	32	14	M6x40	34	47	25	M25x1,5	2	5

Brida de apriete



N° de material
R412010348
R412010349

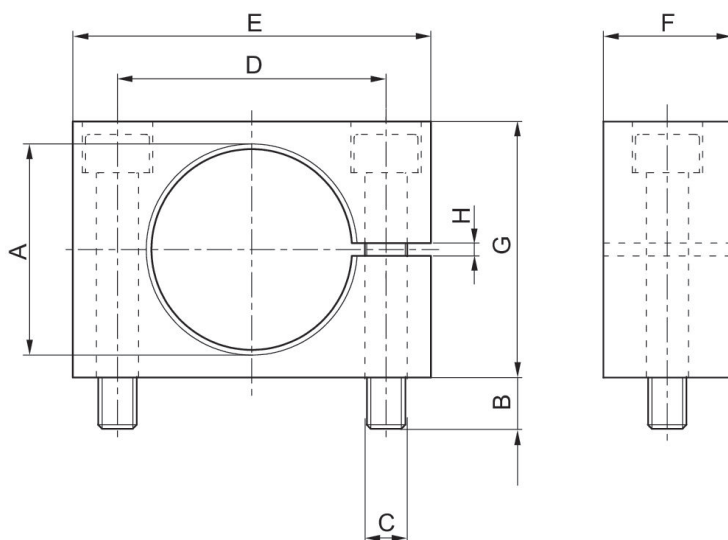

N° de material	A	B	C	D	E	F	G	H
R412010348	M33x1,5	8	M6x40	42	56	20	40	2
R412010349	M64x2	12	M10x80	78	100	25	80	2

Fijación por brida

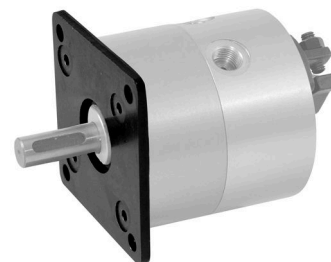

Material	N° de material
Acero, cromado	2706131000
Acero, cromado	2706141000
Acero, cromado	2706151000

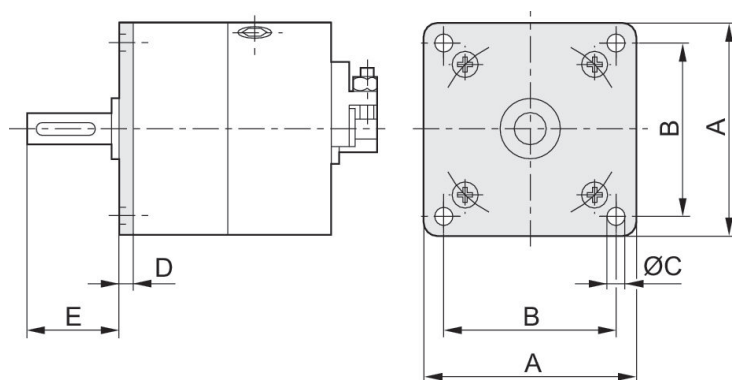

N° de material	Para serie	A	B	C	D	E
2706131000	RAK - 3S	42	34	3.5	3.2	19.8
2706141000	RAK - 4S	50	41	5.5	3.6	24.9
2706151000	RAK - 5S, RAK - 5D	64	52	5.5	3.6	27.9

Fijación por brida

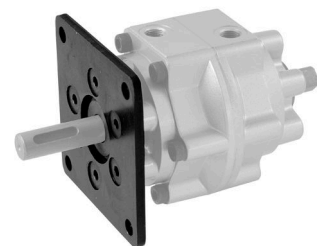

Material	N° de material
Acero, cromado	2706161000
Acero, cromado	2706171000

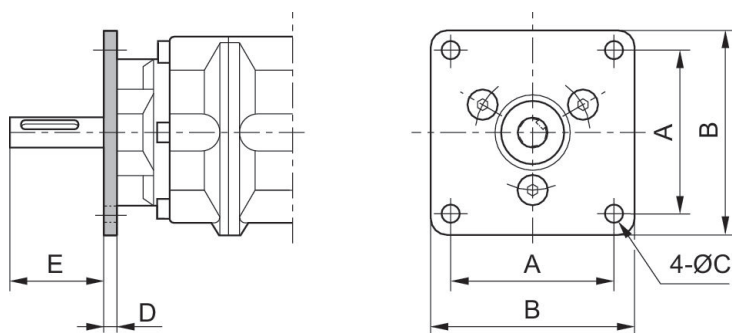

N° de material	Para serie	A	B	C	D	E
2706161000	RAK - 6S, RAK - 6D	64	80	7	4.5	35
2706171000	RAK - 7S, RAK - 7D	88	110	9	6	47.5

Fijación por brida, Serie MF1, MF2

NFPA



Diámetro de émbolo [mm]	Normalización	Material	N° de material
127	NFPA	Aluminio	R432014767
127	NFPA	Aluminio	R432014805
152.4	NFPA	Aluminio	R432014827
152.4	NFPA	Aluminio	R432014852
152.4	NFPA	Aluminio	R432014900
152.4	NFPA	Aluminio	R432030812
38.1	NFPA	Aluminio	R432013373
50.8	NFPA	Aluminio	R432012520
63.5	NFPA	Aluminio	R432013382
82.55	NFPA	Aluminio	R432013388
101.6	NFPA	Aluminio	R432013396

Dimensiones en pulgadas

A - A

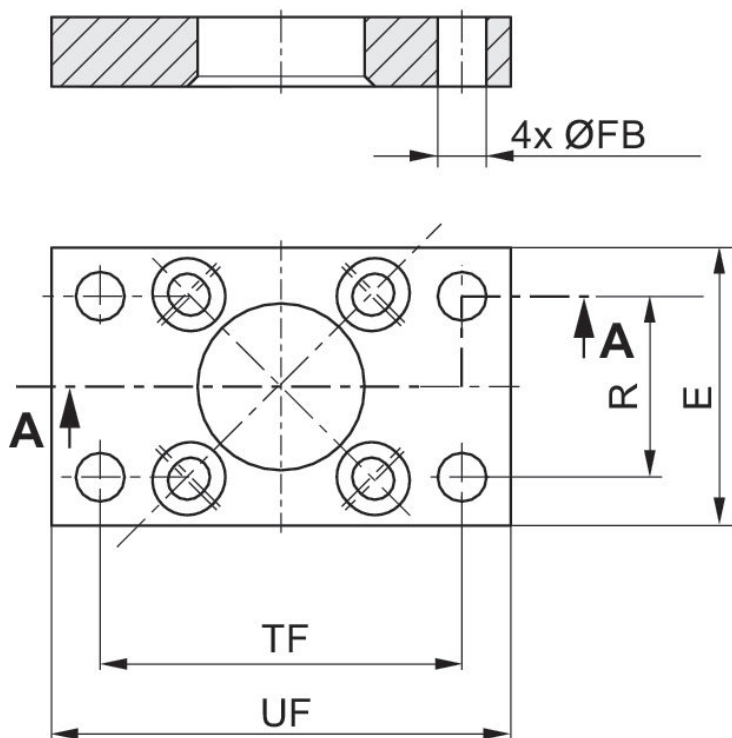

Dimensiones en pulgadas

N° de material	\varnothing	E	$\varnothing FB$	R	TF	UF
R432013373	38.1	2.00	0.34	1.43	2.75	3.38
R432012520	50.8	2.50	0.41	1.84	3.38	4.13
R432013382	63.5	3.00	0.41	2.19	3.88	4.63
R432013388	82.55	3.50	0.47	2.76	4.69	5.50
R432013396	101.6	4.50	0.47	3.32	5.44	6.25

Efficient pneumatic solutions, our program: cylinders and drives, valves and valve systems, air supply management



Visit us: [Emerson.com/Aventics](https://www.emerson.com/aventics)

Your local contact: [Emerson.com/contactus](https://www.emerson.com/contactus)



[Emerson.com](https://www.emerson.com)



[Facebook.com/EmersonAutomationSolutions](https://www.facebook.com/EmersonAutomationSolutions)



[LinkedIn.com/company/Emerson-Automation-Solutions](https://www.linkedin.com/company/Emerson-Automation-Solutions)



[Twitter.com/EMR_Automation](https://twitter.com/EMR_Automation)

An example configuration is depicted on the title page. The delivered product may thus vary from that in the illustration. Subject to change. This Document, as well as the data, specifications and other information set forth in it, are the exclusive property of AVENTICS GmbH. It may not be reproduced or given to third parties without its consent. Only use the AVENTICS products shown in industrial applications. Read the product documentation completely and carefully before using the product. Observe the applicable regulations and laws of the respective country. When integrating the product into applications, note the system manufacturer's specifications for safe use of the product. The data specified only serve to describe the product. No statements concerning a certain condition or suitability for a certain application can be derived from our information. The information given does not release the user from the obligation of own judgment and verification. It must be remembered that the products are subject to a natural process of wear and aging.

The Emerson logo is a trademark and service mark of Emerson Electric Co. Brand logotype are registered trademarks of one of the Emerson family of companies. All other marks are the property of their respective owners. © 2019 Emerson Electric Co. All rights reserved.



CONSIDER IT SOLVED™