

## Serie MSC



**AVENTICS™**

**AVENTICS Führungszylinder der  
Serie MSC**

  
**EMERSON™**

## Serie MSC

Die AVENTICS Minischlitten der Serie MSC sind besonders kompakt gebaut, benötigen minimalen Einbauraum und können für praktisch jede automatisierte Handling-Aufgabe optimal konfiguriert werden. Die vielfältigen Konfigurationsmöglichkeiten machen den Minischlitten zur universellen Handling-Komponente. Eine hochpräzise und zuverlässige Funktionsweise, kombiniert mit individueller Auslegung und auf Ihre Anwendung maßgeschneidert – diese Eigenschaften ermöglichen es den Minischlitten, die Aktorenrolle in der effizienten Handhabung zu übernehmen. Die Serie MSC bietet hohe Drehmomentaufnahme bei maximaler Stabilität. Darüber hinaus kann der Zylinder mit vielen technischen Feinheiten überzeugen, die optimal angepasste Funktionen und wartungsfreundliche Prozesse garantieren. Die Minischlitten sind mit der speziellen Easy-2-Combine-Schnittstelle schnell, sicher und effizient verbunden und können ohne zusätzliche Montageplatten mit anderen Bauteilen eines Handling-Systems kombiniert werden.

- Hohe Drehmoment- und Lastaufnahme bei maximaler Stabilität
- kompakte Bauweise
- Easy-2-Combine-Schnittstelle



Übersichtszeichnung

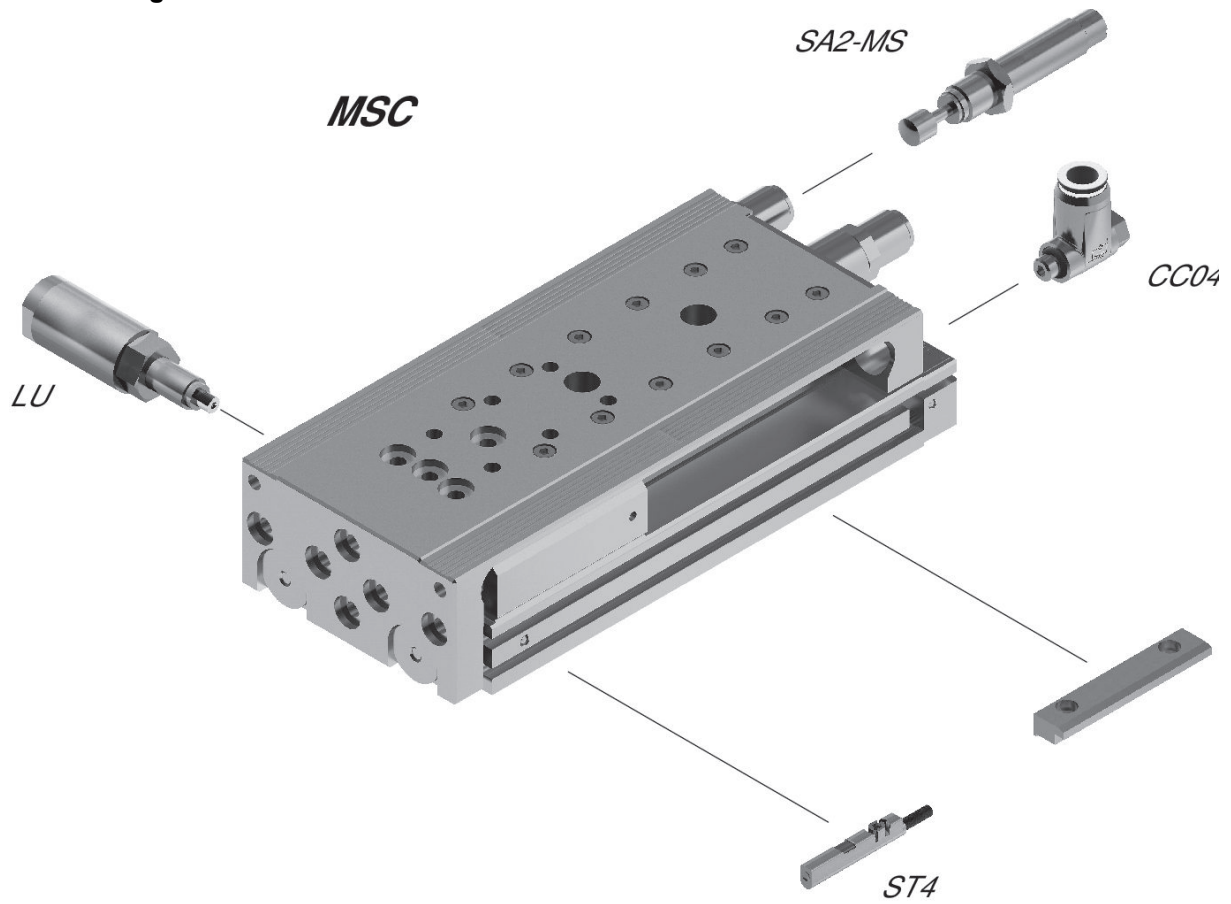

## Produktübersicht

	Seite
<b>Metrisch</b>	
Minischlitten, Serie MSC-HG-EE.....	6
elastisch - mit integrierter „High Performance“ Kugelschienenführung	
Minischlitten, Serie MSC-HG-EM.....	21
elastisch mit Metall-Endanschlag - mit integrierter „High Performance“ Kugelschienenführung	
Minischlitten, Serie MSC-HG-HM.....	36
hydraulisch - mit integrierter „High Performance“ Kugelschienenführung	
Minischlitten, Serie MSC-HG-PM/PE.....	50
pneumatisch - mit integrierter „High Performance“ Kugelschienenführung	
Minischlitten, Serie MSC-MG-EE.....	62
elastisch - mit integrierter Kugelschienenführung	
Minischlitten, Serie MSC-MG-EM.....	76
elastisch mit Metall-Endanschlag - mit integrierter Kugelschienenführung	
Minischlitten, Serie MSC-MG-PM/PE.....	91
pneumatisch - mit integrierter Kugelschienenführung	
Minischlitten, Serie MSC-MG-HM.....	102
hydraulisch - mit integrierter Kugelschienenführung	
<b>Zubehörübersicht Zylinderbefestigungen</b>	
Zentrierringe.....	117
Zentrierringe.....	119
Spannstücke für kolbenstangenlose Zylinder Serie CKP.....	121
<b>Drosselrückschlagventile, Zubehör</b>	
Drosselrückschlagventil, Serie CC04.....	123
Abluftdrosselung - 2 > 1 - Außengewinde	
<b>Hubeinstellungszubehör</b>	
Hubeinstellungszubehör.....	126
<b>Zubehörübersicht Stoßdämpfer</b>	
Industriestoßdämpfer, Serie SA1-MC.....	129
selbsteinstellend - Kontermutter - M12x1	
Industriestoßdämpfer, Serie SA1-MC.....	131
selbsteinstellend - Kontermutter - M20x1,5 Anschlagkopf	
Industriestoßdämpfer, Serie SA2-RC für Minischlitten, Serie MSC.....	133
selbsteinstellend - Kontermutter	
<b>Feststelleinheiten, Zubehör</b>	
Endlagenverriegelung, Serie LU.....	135
<b>Sensoren, -befestigungen, Zubehör</b>	
Sensoren, Serie ST4.....	136
offene Kabelenden	
Sensoren, Serie ST4.....	138
Stecker - M8 - mit Rändelschraube	
Sensoren, Serie ST4.....	140
Stecker - M12 - mit Rändelschraube	
Sensoren, Serie ST4.....	142
Stecker - M8	
Sensoren, Serie ST4-2P.....	144
Stecker - M12x1 - IO-Link 2 Schaltpunkte mit festen Toleranzstufen - elektronisch PNP	

## Produktübersicht

Sensoren, Serie ST4-2P.....	Seite
Stecker - M8x1 - 2 Schaltpunkte - elektronisch PNP	145

### Minischlitten, Serie MSC-HG-EE

Wirkprinzip: doppeltwirkend

Dämpfung: elastisch

Easy2Combine: fähig

: mit Magnetkolben

: mit Doppelkolben

: mit integrierter „High Performance“ Kugelschienenführung

Umgebungstemperatur min./max.: 0 °C ... 60 °C

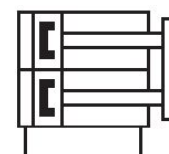

Kolben-Ø	8 mm	12 mm	16 mm	20 mm	25 mm
Anschlüsse	M5	M5	M5	G 1/8	G 1/8
Hub 10	R412019204	R412019190	R412019168	R412018910	R412019023
20	R412019205	R412019191	R412019169	R412018911	R412019024
30	R412019206	R412019192	R412019170	R412018912	R412019025
40	R412019207	R412019193	R412019171	R412018913	R412019026
50	R412019208	R412019194	R412019172	R412018914	R412019027
80	R412019209	R412019195	R412019173	R412018915	R412019028
100	-	R412019196	R412019174	R412018916	R412019029
125	-	-	R412019175	R412018917	R412019030
150	-	-	R412019176	R412018918	R412019031
200	-	-	-	R412018919	R412019032

Kolben-Ø	8 mm	12 mm	16 mm	20 mm	25 mm
Kolbenkraft einfahrend, theoretisch	48 N	107 N	218 N	297 N	520 N
Kolbenkraft ausfahrend, theoretisch	63 N	143 N	253 N	396 N	619 N
Dämpfungsenergie	0.06 J	0.3 J	0.3 J	0.4 J	0.5 J
Dämpfungslänge	0.3 mm	0.75 mm	1 mm	1.2 mm	1.6 mm
Geschwindigkeit max.	0.8 m/s	0.8 m/s	0.8 m/s	0.8 m/s	0.8 m/s
Betriebsdruck min./max.	1.5 bar ... 10 bar	1 bar ... 10 bar	1 bar ... 10 bar	1 bar ... 10 bar	1 bar ... 10 bar

Abmessungen

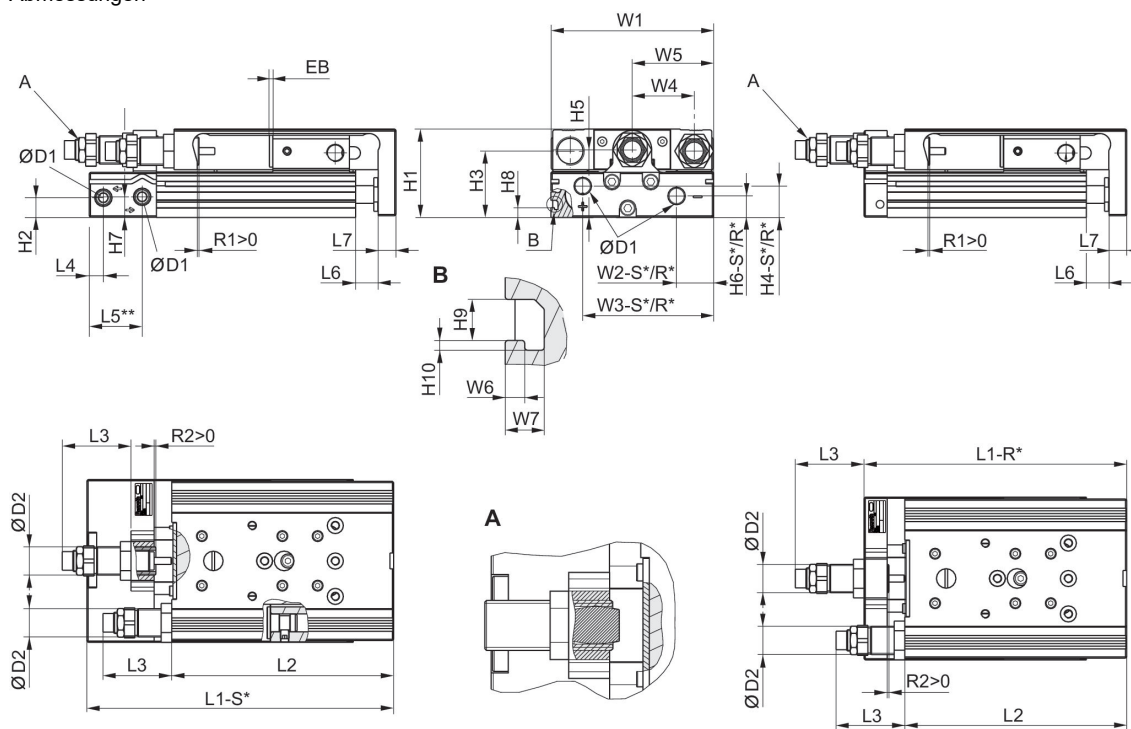

R\*: Bodenausführung mit Luftanschlüssen nur hinten  
 S\*: Bodenausführung mit Luftanschlüssen hinten und seitlich  
 \*\* Ø 8 hat eine andere Bezugsfläche.

Abmessungen

Kolben-Ø	Ø D1	Ø D2	H1	H2	H3	H4-R	H4-S	H5	H6-R
8	M5	M10x1	28	9.6	20.5	-	7.5	19.5	-
12	M5	M12x1	34	5.7	25	11.2	11.2	24.5	5.7
16	M5	M12x1	40	7.2	29	12.2	12.2	31	7.7
20	G 1/8	M16x1,5	50	11.2	37.5	17.3	17.3	38.2	11.7
25	G 1/8	M18x1,5	60	14.2	44	15.5	22.9	46.5	13.2

Kolben-Ø	H6-S	H7	H8	H9	H10	L3 max.	L4	L5 2)	L6
8	5.5	18	-	-	-	16	9.8	-	1.9
12	5.7	8.3	-	-	-	20.2	7.2	22.5	2
16	7.7	11.2	-	-	-	18.4	6.5	17.7	2
20	12.2	11.7	5.5	4.2	1	27.9	8	30	2.1
25	21.7	16.2	6.9	5.2	1.5	29.2	9	31	2.1

Kolben-Ø	L7	R2 max.	W1	W2-R	W2-S	W3-R	W3-S	W4	W5
8	6	9.1	50.2	–	19.3	–	30.5	18	W1/2
12	8	14	66	28.8	28.8	53	53	24.5	W1/2
16	10	12.4	76	31	31	60.5	60.5	30	W1/2
20	10	19.9	92	10	21	74	74	35	W1/2
25	12	22.2	112	11	14	92	92	44	W1/2

Kolben-Ø	W6	W7
8	–	–
12	–	–
16	–	–
20	2	4
25	2.5	4.8

## Hubabhängige Maße

Kolben-Ø	S=10 EB	S=20 EB	S=30 EB	S=40 EB	S=50 EB	S=80 EB	S=100 EB	S=125 EB	S=150 EB
8	12	2	2	2	2	2	–	–	–
12	22	12	2	2	2	2	2	–	–
16	22	12	2	2	2	2	2	2	2
20	22	12	2	2	2	2	2	2	2
25	22	12	2	2	2	2	2	2	2

Kolben-Ø	S=200 EB	S=10 L1-R	S=20 L1-R	S=30 L1-R	S=40 L1-R	S=50 L1-R	S=80 L1-R	S=100 L1-R	S=125 L1-R
8	–	–	–	–	–	–	–	–	–
12	–	101	101	101	111	126	172	192	–
16	–	103.5	103.5	103.5	113.5	128.5	174.5	194.5	283
20	2	115	115	115	125	140	185	205	289.5
25	2	128.5	128.5	128.5	138.5	151.5	197.5	217.5	294.5

Kolben-Ø	S=150 L1-R	S=200 L1-R	S=10 L1-S	S=20 L1-S	S=30 L1-S	S=40 L1-S	S=50 L1-S	S=80 L1-S	S=100 L1-S
8	–	–	81.7	81.7	91.7	101.7	121.7	171.7	–
12	–	–	117.9	117.9	117.9	127.9	142.9	188.9	208.9
16	308	–	114.4	114.4	114.4	124.4	139.4	185.4	205.4
20	329.5	404.5	139.9	139.9	139.9	149.9	164.9	209.9	229.9
25	334.5	409.5	152.2	152.2	152.2	162.2	175.2	221.2	241.2

Kolben-Ø	S=125 L1-S	S=150 L1-S	S=200 L1-S	S=10 L2	S=20 L2	S=30 L2	S=40 L2	S=50 L2	S=80 L2
8	–	–	–	73.5	73.5	83.5	93.5	113.5	163.5
12	–	–	–	88.8	88.8	88.8	98.8	113.8	159.8
16	293.9	318.9	–	90.4	90.4	90.4	100.4	115.4	161.4
20	314.4	354.4	429.4	100.5	100.5	100.5	110.5	125.5	170.5
25	318.2	358.2	433.2	111.5	111.5	111.5	121.5	134.5	180.5

Kolben-Ø	S=100 L2	S=125 L2	S=150 L2	S=200 L2	S=10 R1 max.	S=20 R1 max.	S=30 R1 max.	S=40 R1 max.	S=50 R1 max.
8	-	-	-	-	9.2	9.2	9.2	9.2	9.2
12	179.8			-	7.7	7.7	7.7	7.7	7.7
16	181.4	269.9	294.9	-	10.7	10.7	10.7	10.7	10.7
20	190.5	275	315	390	18.4	18.4	18.4	18.4	18.4
25	200.5	277.5	317.5	392.5	17.5	17.5	17.5	17.5	16.5

Kolben-Ø	S=80 R1 max.	S=100 R1 max.	S=125 R1 max.	S=150 R1 max.	S=200 R1 max.
8	9.2	-	-	-	-
12	7.7	7.7	-	-	-
16	10.7	10.7	10.7	10.7	-
20	18.4	18.4	18.4	18.4	18.4
25	17.5	17.5	17.5	17.5	17.5

## Abmessungen MSC-08

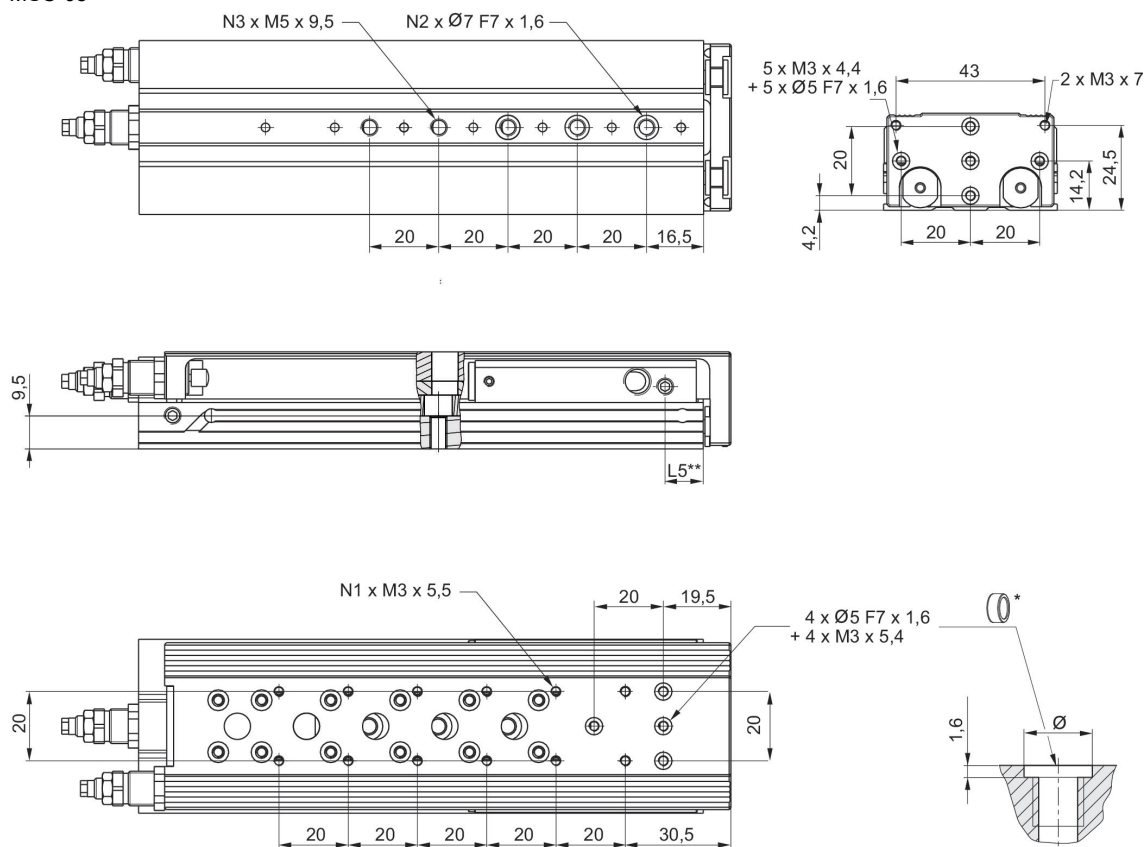

\* = Zentrierringe

\*\* Ø 8 hat eine andere Bezugsfläche.

Materialnummer	Kolben-Ø	Hub	N1	N2	N3	L5
R480643788	8	10	4	2	2	11
R480643789	8	20	4	2	2	11
R480643790	8	30	4	2	2	11
R480643791	8	40	6	2	2	11
R480643792	8	50	8	3	3	11
R480643793	8	80	12	3	5	11

Materialnummer	Kolben-Ø	Hub	N1	N2	N3	L5
R412019204	8	10	4	2	2	11
R412019205	8	20	4	2	2	11
R412019206	8	30	4	2	2	11
R412019207	8	40	6	2	2	11
R412019208	8	50	8	3	3	11
R412019209	8	80	12	3	5	11

## Abmessungen MSC-12

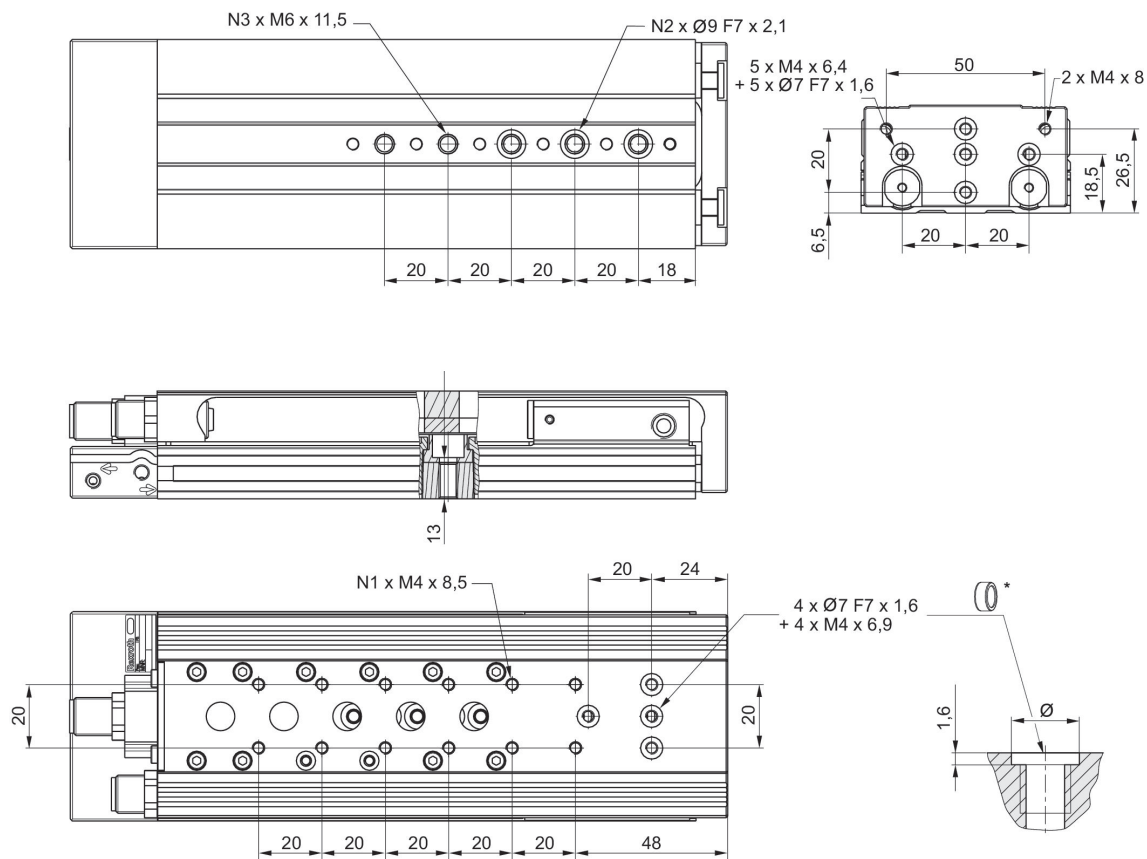

\* = Zentrierringe

Materialnummer	Kolben-Ø	Hub	N1	N2	N3
R412019190	12	10	4	2	2
R412019191	12	20	4	2	2
R412019192	12	30	4	2	2
R412019193	12	40	4	2	2
R412019194	12	50	6	3	3
R412019195	12	80	10	3	5
R412019196	12	100	12	3	5

## Abmessungen MSC-16

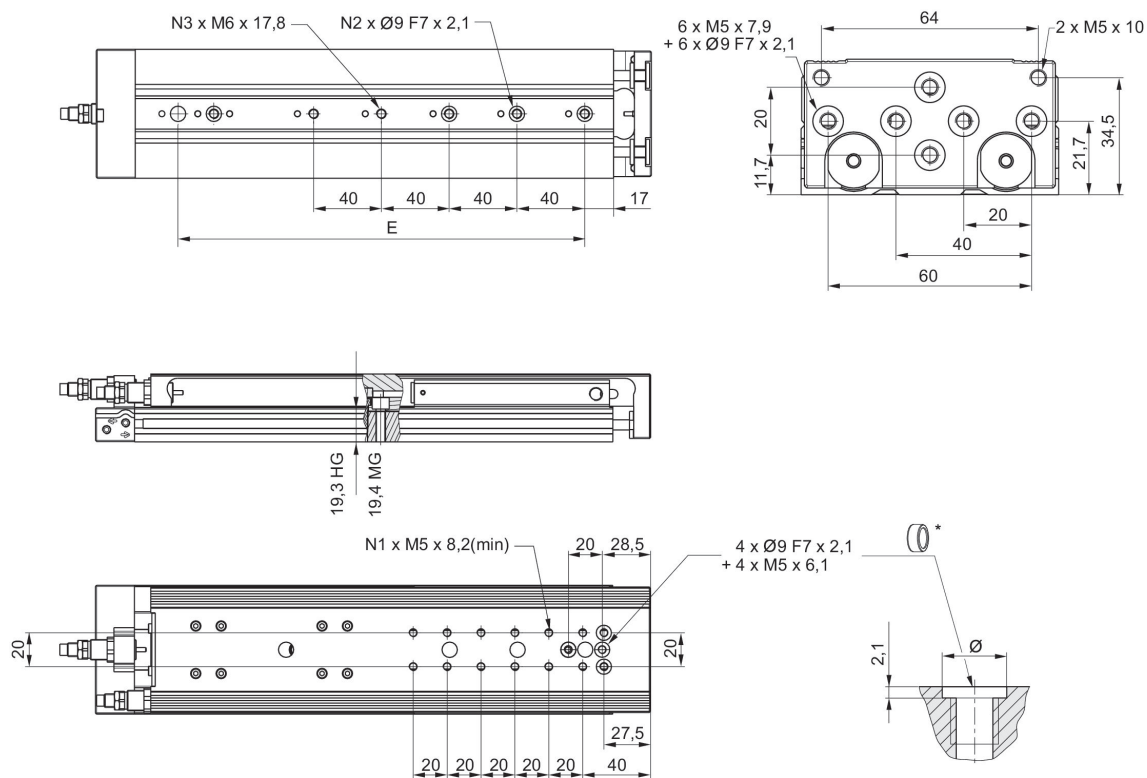

\* = Zentrierringe

Materialnummer	Kolben-Ø	Hub	E	N1	N2	N3
R412019175	16	125	200	12	4	5
R480643808	16	125	200	12	4	5
R412019188	16	125	200	12	4	5
R480640200	16	125	200	12	4	5
R412019176	16	150	240	12	4	5
R480643809	16	150	240	12	4	5
R412019189	16	150	240	12	4	5
R480640201	16	150	240	12	4	5

Materialnummer	Kolben-Ø	Hub	E	N1	N2	N3
R412019168	16	10	-	4	2	2
R412019169	16	20	-	4	2	2
R412019170	16	30	-	4	2	2
R412019171	16	40	-	4	2	2
R412019172	16	50	-	6	2	2
R412019173	16	80	-	6	3	3
R412019174	16	100	-	8	3	3

## Abmessungen MSC-20

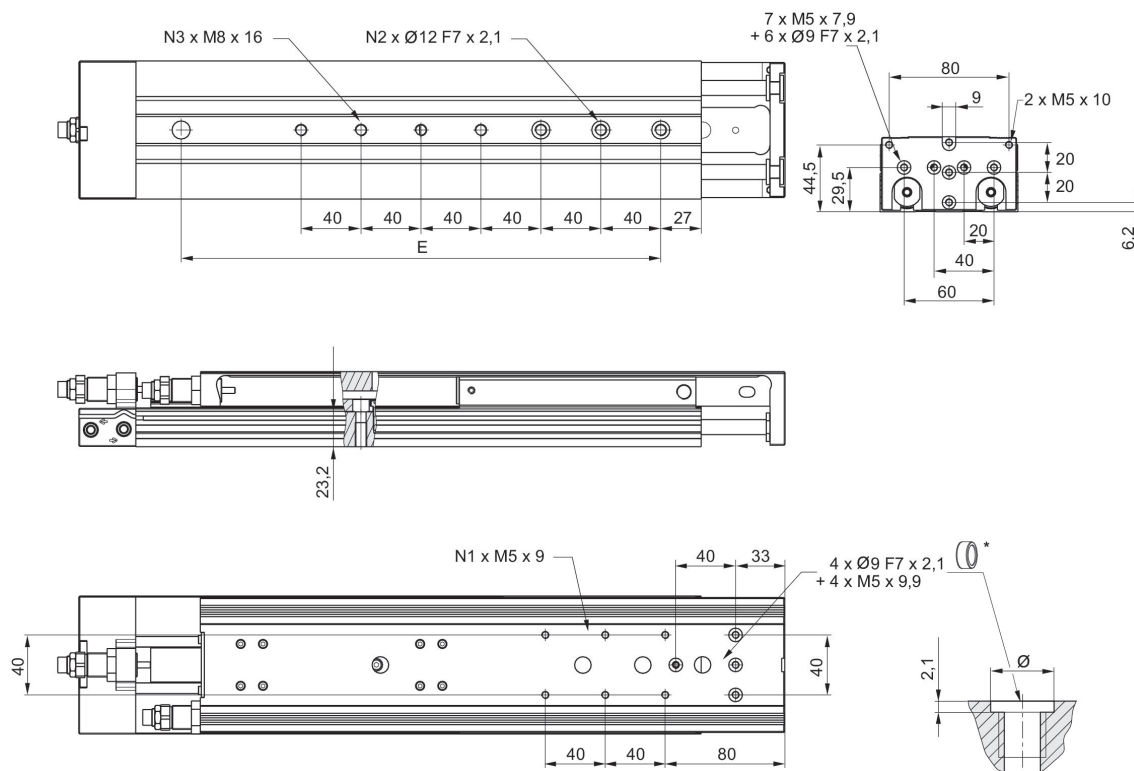

\* = Zentrierringe

Materialnummer	Kolben-Ø	Hub	E	N1	N2	N3
R412018910	20	10	-	2	2	2
R412018911	20	20	-	2	2	2
R412018912	20	30	-	2	2	2
R412018913	20	40	-	2	2	2
R412018914	20	50	-	2	2	2
R412018915	20	80	-	4	3	3
R412018916	20	100	-	4	3	3

Materialnummer	Kolben-Ø	Hub	E	N1	N2	N3
R412018917	20	125	200	6	4	5
R480643817	20	125	200	6	4	5
R412019005	20	125	200	6	4	5
R480640205	20	125	200	6	4	5
R412018918	20	150	240	6	4	5
R480643818	20	150	240	6	4	5
R412019006	20	150	240	6	4	5
R480640206	20	150	240	6	4	5
R412018919	20	200	320	6	4	7
R480643819	20	200	320	6	4	7
R412019007	20	200	320	6	4	7
R480640207	20	200	320	6	4	7

## Abmessungen MSC-25

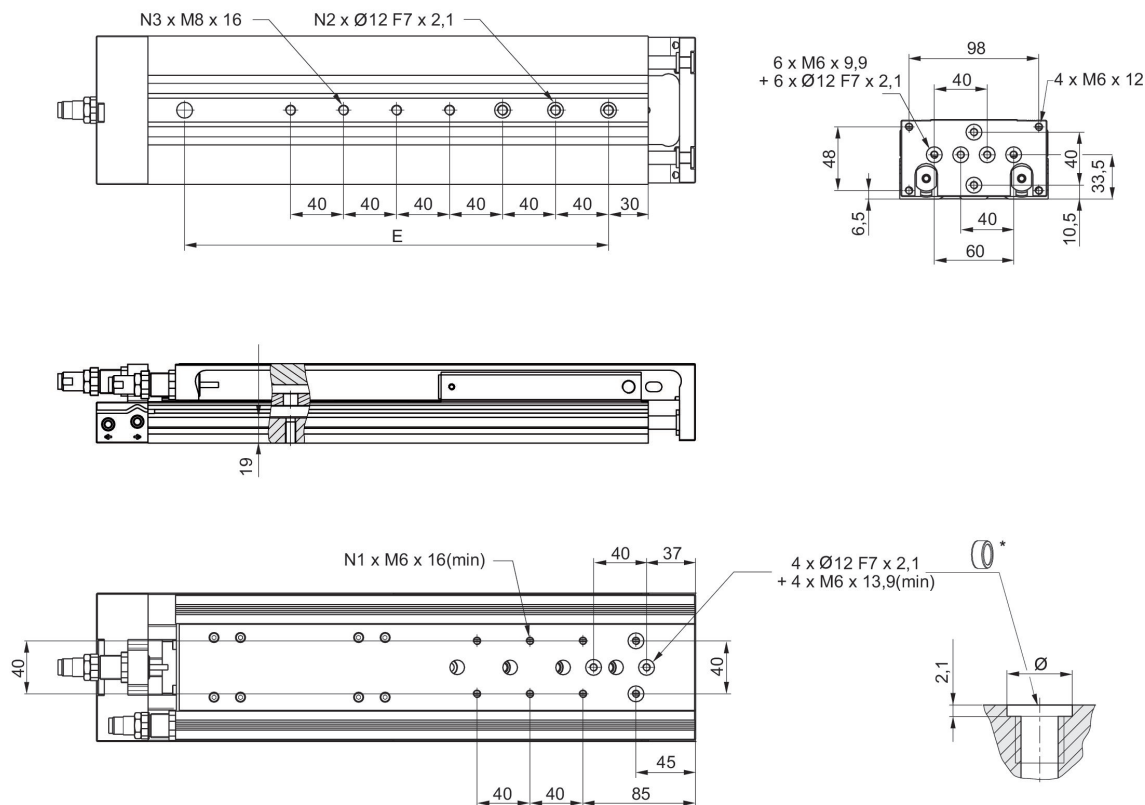

\* = Zentrierringe

Materialnummer	Kolben-Ø	Hub	E	N1	N2	N3
R480643820	25	10	-	2	2	2
R480643821	25	20	-	2	2	2
R480643822	25	30	-	2	2	2
R480643823	25	40	-	2	2	2
R480643824	25	50	-	4	2	2
R480643825	25	80	-	4	3	3
R480643826	25	100	-	4	3	3

Materialnummer	Kolben-Ø	Hub	E	N1	N2	N3
R412019030	25	125	200	4	4	5
R480643827	25	125	200	4	4	5
R412019041	25	125	200	4	4	5
R480640211	25	125	200	4	4	5
R412019031	25	150	240	6	4	5
R480643828	25	150	240	6	4	5
R412019042	25	150	240	6	4	5
R480640212	25	150	240	6	4	5
R412019032	25	200	320	6	4	7
R480643829	25	200	320	6	4	7
R412019043	25	200	320	6	4	7
R480640213	25	200	320	6	4	7

Tragfähigkeit

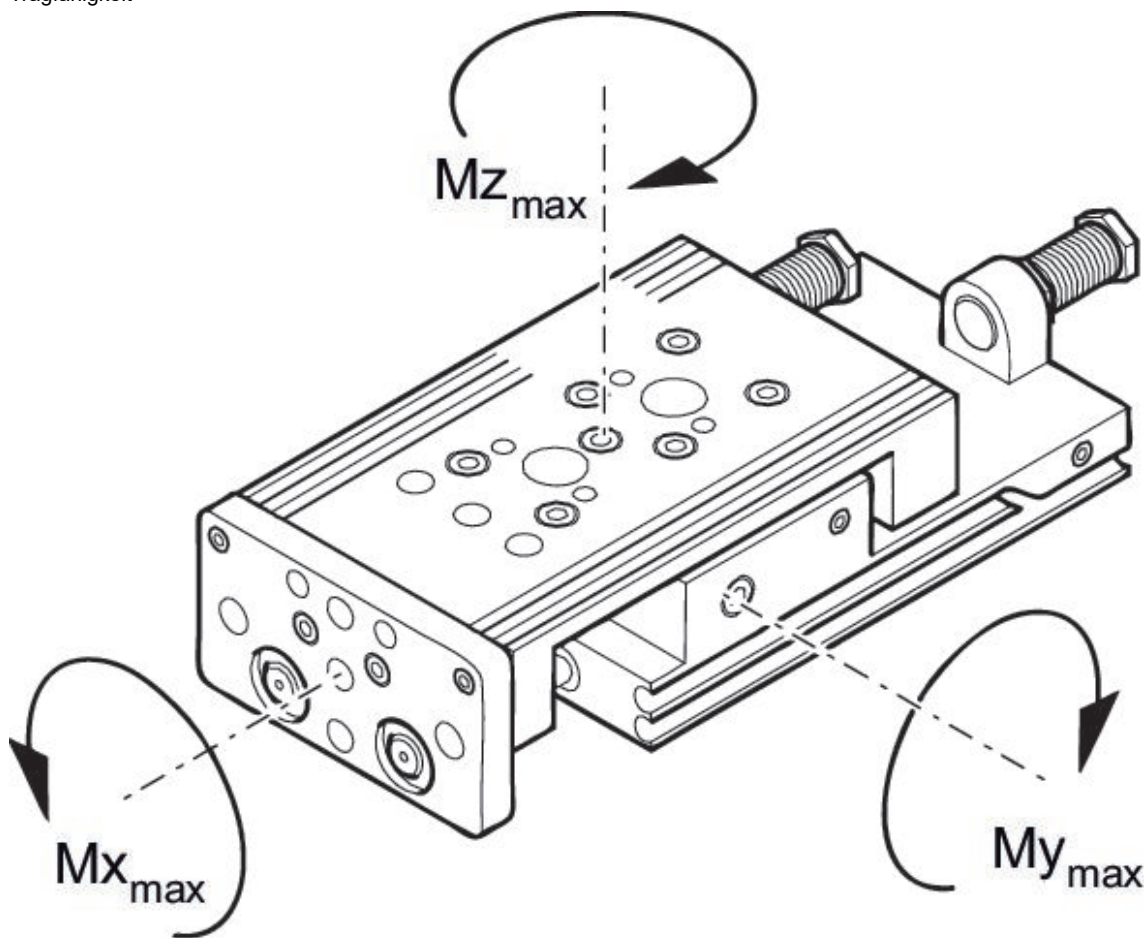

M = max. zulässiges Drehmoment

Korrekturfaktor (a)

Materialnummer	Kolben-Ø	Hub	a [mm]	d [mm]	$M_{x_{max}}$ [Nm]	$M_{y_{max}}$ [Nm]	$M_{z_{max}}$ [Nm]
R412019204	8	10	45	14	7	7	7
R412019205	8	20	50	14	7	7	7
R412019206	8	30	60	14	7	7	7
R412019207	8	40	70	14	7	7	7
R412019208	8	50	80	14	9	13	13
R412019209	8	80	125	14	13	25	25
R412019190	12	10	54.5	16	20	14	14
R412019191	12	20	59.5	16	20	14	14
R412019192	12	30	64.5	16	20	14	14
R412019193	12	40	74.5	16	20	14	14
R412019194	12	50	84.5	16	23	19	19
R412019195	12	80	125	16	33	32	32
R412019196	12	100	145	16	33	32	32
R412019168	16	10	55.5	15	35	25	25
R412019169	16	20	60.5	15	35	25	25
R412019170	16	30	65.5	15	35	25	25
R412019171	16	40	75.5	15	35	25	25
R412019172	16	50	85.5	15	38	29	29
R412019173	16	80	126	15	74	58	58
R412019174	16	100	146	15	74	58	58
R412019175	16	125	198.5	15	88	118	118
R412019176	16	150	223.5	15	88	119	119
R412018910	20	10	60.5	20	87	57	57
R412018911	20	20	65.5	20	87	57	57
R412018912	20	30	70.5	20	87	57	57
R412018913	20	40	80.5	20	87	57	57
R412018914	20	50	90.5	20	93	65	65
R412018915	20	80	130.5	20	116	99	99
R412018916	20	100	150.5	20	116	99	99
R412018917	20	125	201	20	126	136	136
R412018918	20	150	233.5	20	126	152	152
R412018919	20	200	296	20	126	179	179
R412019023	25	10	67.5	24	100	90	90
R412019024	25	20	72.5	24	100	90	90
R412019025	25	30	77.5	24	100	90	90
R412019026	25	40	87.5	24	100	90	90
R412019027	25	50	96.5	24	100	90	90
R412019028	25	80	137	24	110	129	129
R412019029	25	100	157	24	110	129	129
R412019030	25	125	201	24	145	180	180
R412019031	25	150	236.5	24	145	201	201
R412019032	25	200	299	24	145	236	236

Gewicht beweglicher Teile [kg]

Kolben-Ø	S=10	S=20	S=30	S=40	S=50	S=80	S=100	S=125	S=150
8	0.14	0.14	0.155	0.165	0.195	0.265	-	-	-
12	0.255	0.255	0.26	0.28	0.315	0.403	0.46	-	-
16	0.375	0.375	0.375	0.4	0.45	0.615	0.65	0.725	0.765
20	0.655	0.655	0.655	0.69	0.765	0.985	1.035	1.2	1.29
25	1	1	1	1.1	1.225	1.45	1.625	1.885	2.085

Kolben-Ø	S=200
8	-
12	-
16	-
20	1.54
25	2.445

Korrekturfaktor (a, d)

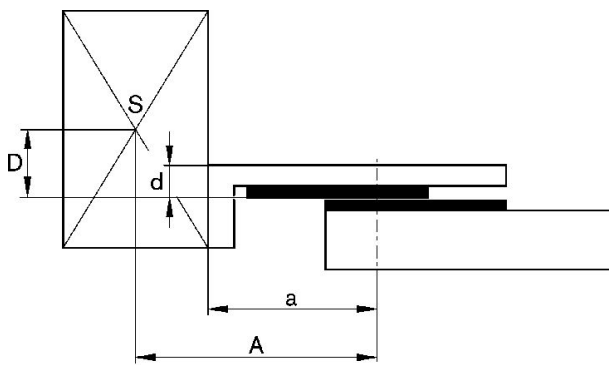

Korrekturfaktor (a, d)

horizontal

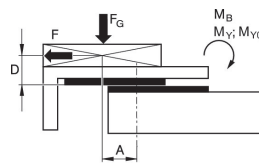

stat.	$M_{B0} = F_G \cdot A + F \cdot D$
dyn.	$M_B = F_G \cdot A$

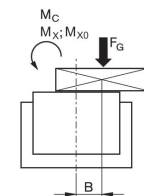

stat.	$M_{C0} = F_G \cdot B$
dyn.	$M_C = F_G \cdot B$

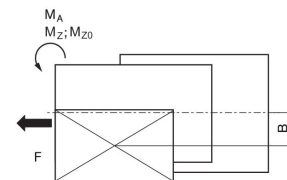

stat.	$M_{A0} = F \cdot B$
dyn.	$M_A = 0$

dyn.	$\frac{M_A}{M_1} + \frac{M_B}{M_2} + \frac{M_C}{M_3} \leq 1$
stat.	$\frac{M_{A0}}{M_{Z0}} + \frac{M_{B0}}{M_{Y0}} + \frac{M_{C0}}{M_{X0}} \leq 1$

$F = m \cdot a$   $F_G = m \cdot g$   $a = 1250 \cdot V^2 / H$   
 F = Verzögerungskraft [N]  $F_G$  = Gewichtskraft [N] m = Lastmasse [kg] a = Verzögerung [m/s<sup>2</sup>] g = Erdbeschleunigung 9,81 [m/s<sup>2</sup>] V = Geschwindigkeit H = Stoßdämpfers Hublänge [mm]

Korrekturfaktor (a, d)

vertikal

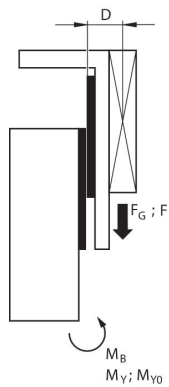

stat.	$M_{B0} = (F_G + F) \cdot D$
dyn.	$M_B = F_G \cdot D$

Maximal bewegte Masse

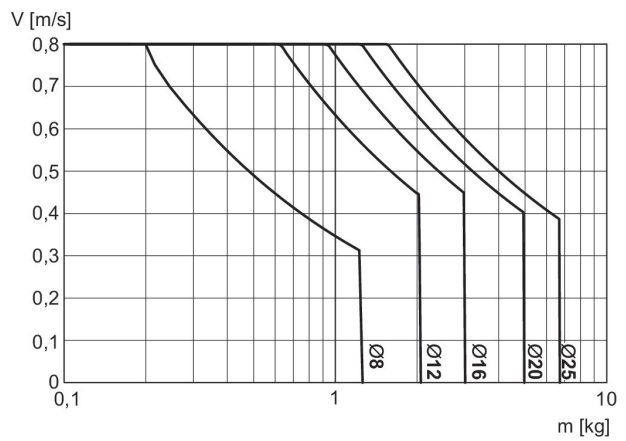

V = Geschwindigkeit [m/s]  
m = Masse

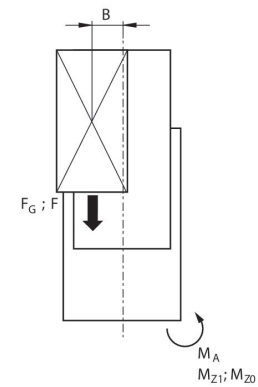

stat.	$M_{A0} = (F_G + F) \cdot B$
dyn.	$M_A = F_G \cdot B$

dyn.	$\frac{M_A}{M_1} + \frac{M_B}{M_2} \leq 1$
stat.	$\frac{M_{A0}}{M_{Z0}} + \frac{M_{B0}}{M_{Y0}} \leq 1$

$F = m \cdot a$   $F_G = m \cdot g$   $a = 1250 \cdot V^2 / H$   
 F = Verzögerungskraft [N]  $F_G$  = Gewichtskraft [N] m = Lastmasse [kg] a = Verzögerung [m/s<sup>2</sup>]  
 g = Erdbeschleunigung 9,81 [m/s<sup>2</sup>] V = Geschwindigkeit H = Stoßdämpfers Hublänge [mm]

**Korrekturfaktor erforderliche Geschwindigkeit ein- und ausfahrend, horizontal**

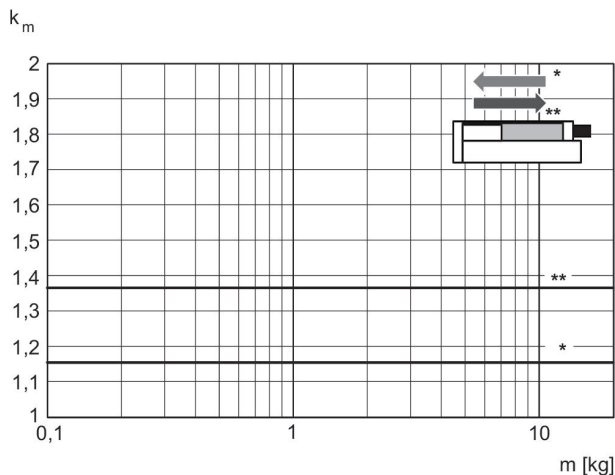

\* einfahrend  
\*\* ausfahrend  
 $V = s/1000 \cdot t \cdot km$   
V = Geschwindigkeit [m/s]  
S = Hub

**Korrekturfaktor erforderliche Geschwindigkeit ausfahrend, vertikal, nach oben**

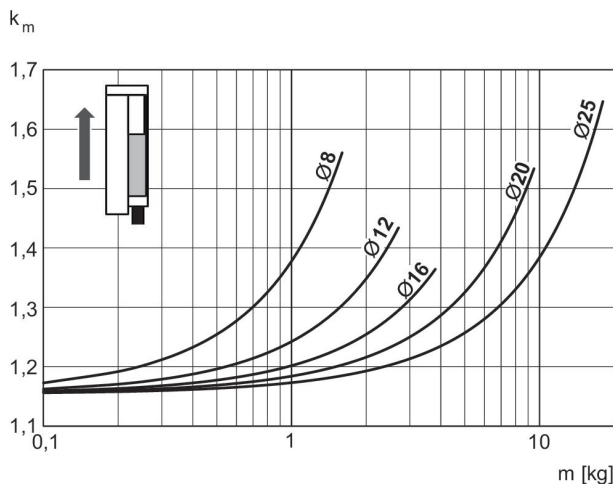

$V = s/1000 \cdot t \cdot km$   
V = Geschwindigkeit [m/s]  
S = Hub [mm]  
t = Zeit [s] für einen Hub  
m = Masse

**Korrekturfaktor erforderliche Geschwindigkeit einfahrend, vertikal, nach oben**

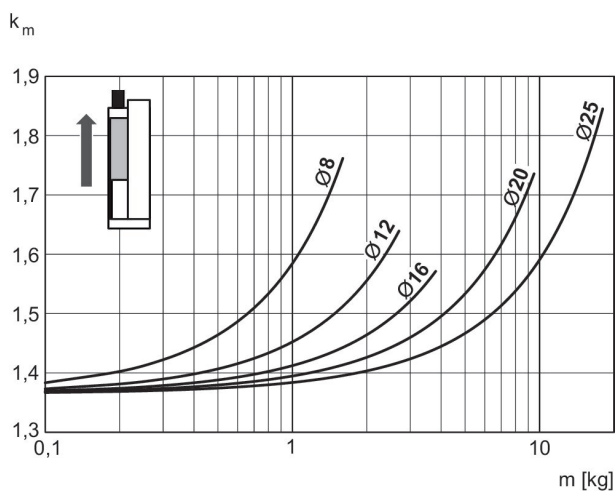

$V = s/1000 \cdot t \cdot km$   
V = Geschwindigkeit [m/s]  
S = Hub [mm]  
t = Zeit [s] für einen Hub  
m = Masse

**Korrekturfaktor erforderliche Geschwindigkeit einfahrend, vertikal, nach unten**

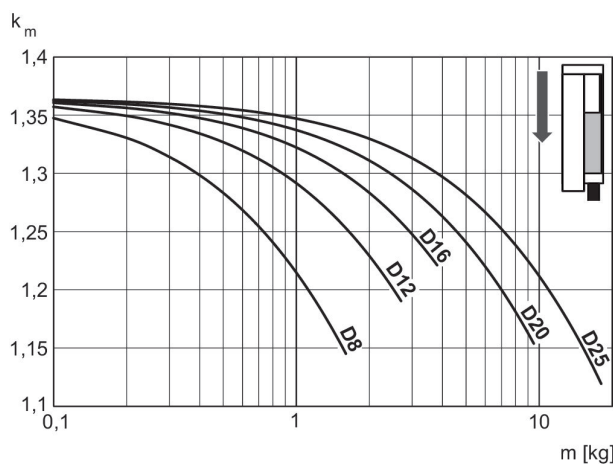

$V = s/1000 \cdot t \cdot km$   
V = Geschwindigkeit [m/s]  
S = Hub [mm]  
t = Zeit [s] für einen Hub  
m = Masse

**Korrekturfaktor erforderliche Geschwindigkeit ausfahrend, vertikal, nach unten**

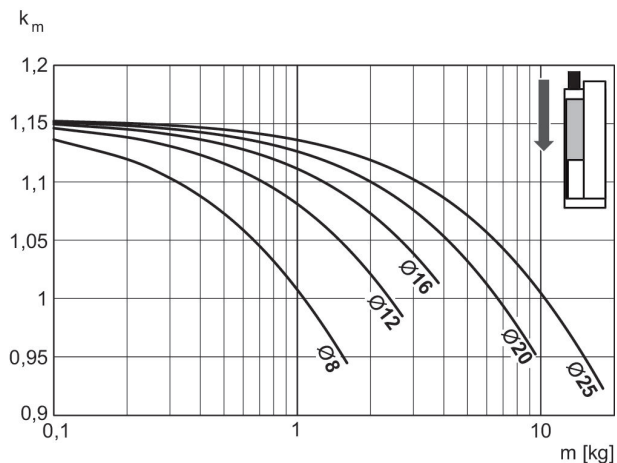

$V = s/1000 \cdot t \cdot km$   
 $V$  = Geschwindigkeit [m/s]  
 $S$  = Hub [mm]  
 $t$  = Zeit [s] für einen Hub  
 $m$  = Masse

**Faktor erreichbare Geschwindigkeit**

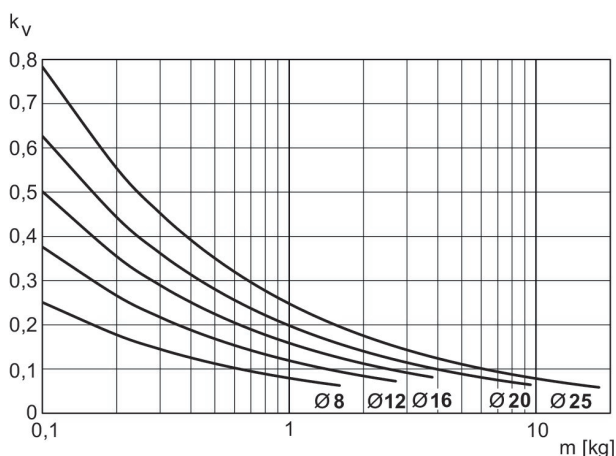

$V = \sqrt{s} \cdot kv$   
 $V$  = Geschwindigkeit [m/s]  
 $S$  = Hub [mm]  
 $m$  = Masse

### Minischlitten, Serie MSC-HG-EM

Wirkprinzip: doppeltwirkend

Dämpfung: elastisch mit Metall-Endanschlag

Easy2Combine: fähig

: mit Magnetkolben

: mit Doppelkolben

: mit integrierter „High Performance“ Kugelschienenführung

Umgebungstemperatur min./max.: 0 °C ... 60 °C

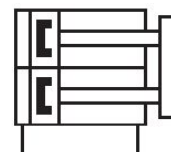

Kolben-Ø	8 mm	12 mm	16 mm	20 mm	25 mm
Anschlüsse	M5	M5	M5	G 1/8	G 1/8
Hub 10	R480643788	R480643794	R480643801	R480643810	R480643820
20	R480643789	R480643795	R480643802	R480643811	R480643821
30	R480643790	R480643796	R480643803	R480643812	R480643822
40	R480643791	R480643797	R480643804	R480643813	R480643823
50	R480643792	R480643798	R480643805	R480643814	R480643824
80	R480643793	R480643799	R480643806	R480643815	R480643825
100	-	R480643800	R480643807	R480643816	R480643826
125	-	-	R480643808	R480643817	R480643827
150	-	-	R480643809	R480643818	R480643828
200	-	-	-	R480643819	R480643829

Kolben-Ø	8 mm	12 mm	16 mm	20 mm	25 mm
Kolbenkraft einfahrend, theoretisch	48 N	107 N	218 N	297 N	520 N
Kolbenkraft ausfahrend, theoretisch	63 N	143 N	253 N	396 N	619 N
Dämpfungsenergie	0.03 J	0.06 J	0.12 J	0.3 J	0.4 J
Dämpfungslänge	0.65 mm	1.9 mm	1.9 mm	3.05 mm	2.5 mm
Geschwindigkeit max.	0.8 m/s	0.8 m/s	0.8 m/s	0.8 m/s	0.8 m/s
Betriebsdruck min./max.	3 bar ... 10 bar	3 bar ... 10 bar	3 bar ... 10 bar	3 bar ... 10 bar	3 bar ... 10 bar

Abmessungen

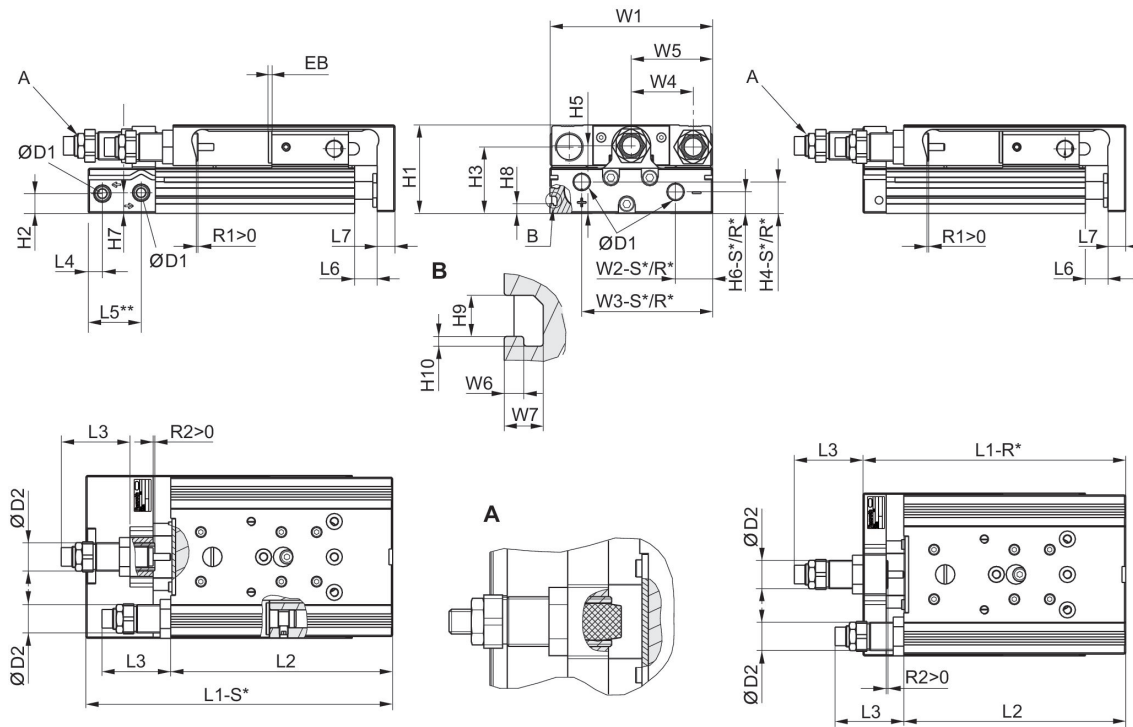

R\*: Bodenausführung mit Luftanschlüssen nur hinten  
S\*: Bodenausführung mit Luftanschlüssen hinten und seitlich  
\*\* Ø 8 hat eine andere Bezugsfläche.

Kolben-Ø	Ø D1	Ø D2	H1	H2	H3	H4-R	H4-S	H5	H6-R
8	M5	M10x1	28	9.6	20.5	-	7.5	19.5	-
12	M5	M12x1	34	5.7	25	11.2	11.2	24.5	5.7
16	M5	M12x1	40	7.2	29	12.2	12.2	31	7.7
20	G 1/8	M16x1,5	50	11.2	37.5	17.3	17.3	38.2	11.7
25	G 1/8	M18x1,5	60	14.2	44	15.5	22.9	46.5	13.2

Kolben-Ø	H6-S	H7	H8	H9	H10	L3 max.	L4	L5 2)	L6
8	5.5	18	-	-	-	27.8	9.8	-	1.9
12	5.7	8.3	-	-	-	31.8	7.2	22.5	2
16	7.7	11.2	-	-	-	30	6.5	17.7	2
20	12.2	11.7	5.5	4.2	1	43.7	8	30	2.1
25	21.7	16.2	6.9	5.2	1.5	41.9	9	31	2.1

Kolben-Ø	L7	R2 max.	W1	W2-R	W2-S	W3-R	W3-S	W4	W5
8	6	4.1	50.2	-	19.3	-	30.5	18	W1/2
12	8	12	66	28.8	28.8	53	53	24.5	W1/2
16	10	10.4	76	31	31	60.5	60.5	30	W1/2
20	10	14	92	10	21	74	74	35	W1/2
25	12	16.2	112	11	14	92	92	44	W1/2

Kolben-Ø	W6	W7
8	–	–
12	–	–
16	–	–
20	2	4
25	2.5	4.8

## Hubabhängige Maße

Kolben-Ø	S=10 EB	S=20 EB	S=30 EB	S=40 EB	S=50 EB	S=80 EB	S=100 EB	S=125 EB	S=150 EB
8	12	2	2	2	2	2	–	–	–
12	22	12	2	2	2	2	2	–	–
16	22	12	2	2	2	2	2	2	2
20	22	12	2	2	2	2	2	2	2
25	22	12	2	2	2	2	2	2	2

Kolben-Ø	S=200 EB	S=10 L1-R	S=20 L1-R	S=30 L1-R	S=40 L1-R	S=50 L1-R	S=80 L1-R	S=100 L1-R	S=125 L1-R
8	–	–	–	–	–	–	–	–	–
12	–	101	101	101	111	126	172	192	–
16	–	103.5	103.5	103.5	113.5	128.5	174.5	194.5	283
20	2	115	115	115	125	140	185	205	289.5
25	2	128.5	128.5	128.5	138.5	151.5	197.5	217.5	294.5

Kolben-Ø	S=150 L1-R	S=200 L1-R	S=10 L1-S	S=20 L1-S	S=30 L1-S	S=40 L1-S	S=50 L1-S	S=80 L1-S	S=100 L1-S
8	–	–	81.7	81.7	91.7	101.7	121.7	171.7	–
12	–	–	117.9	117.9	117.9	127.9	142.9	188.9	208.9
16	308	–	114.4	114.4	114.4	124.4	139.4	185.4	205.4
20	329.5	404.5	139.9	139.9	139.9	149.9	164.9	209.9	229.9
25	334.5	409.5	152.2	152.2	152.2	162.2	175.2	221.2	241.2

Kolben-Ø	S=125 L1-S	S=150 L1-S	S=200 L1-S	S=10 L2	S=20 L2	S=30 L2	S=40 L2	S=50 L2	S=80 L2
8	–	–	–	73.5	73.5	83.5	93.5	113.5	163.5
12	–	–	–	88.8	88.8	88.8	98.8	113.8	159.8
16	293.9	318.9	–	90.4	90.4	90.4	100.4	115.4	161.4
20	314.4	354.4	429.4	100.5	100.5	100.5	110.5	125.5	170.5
25	318.2	358.2	433.2	111.5	111.5	111.5	121.5	134.5	180.5

Kolben-Ø	S=100 L2	S=125 L2	S=150 L2	S=200 L2	S=10 R1 max.	S=20 R1 max.	S=30 R1 max.	S=40 R1 max.	S=50 R1 max.
8	–	–	–	–	4.2	4.2	4.2	4.2	4.2
12	179.8	–	–	–	5.7	5.7	5.7	5.7	5.7
16	181.4	269.9	294.9	–	8.7	8.7	8.7	8.7	8.7
20	190.5	275	315	390	12.4	12.4	12.4	12.4	12.4
25	200.5	277.5	317.5	392.5	11.5	11.5	11.5	11.5	10.5

Kolben-Ø	S=80 R1 max.	S=100 R1 max.	S=125 R1 max.	S=150 R1 max.	S=200 R1 max.
8	4.2	-	-	-	-
12	5.7	5.7	-	-	-
16	8.7	8.7	8.7	8.7	-
20	12.4	12.4	12.4	12.4	12.4
25	11.5	11.5	11.5	11.5	11.5

## Abmessungen MSC-08

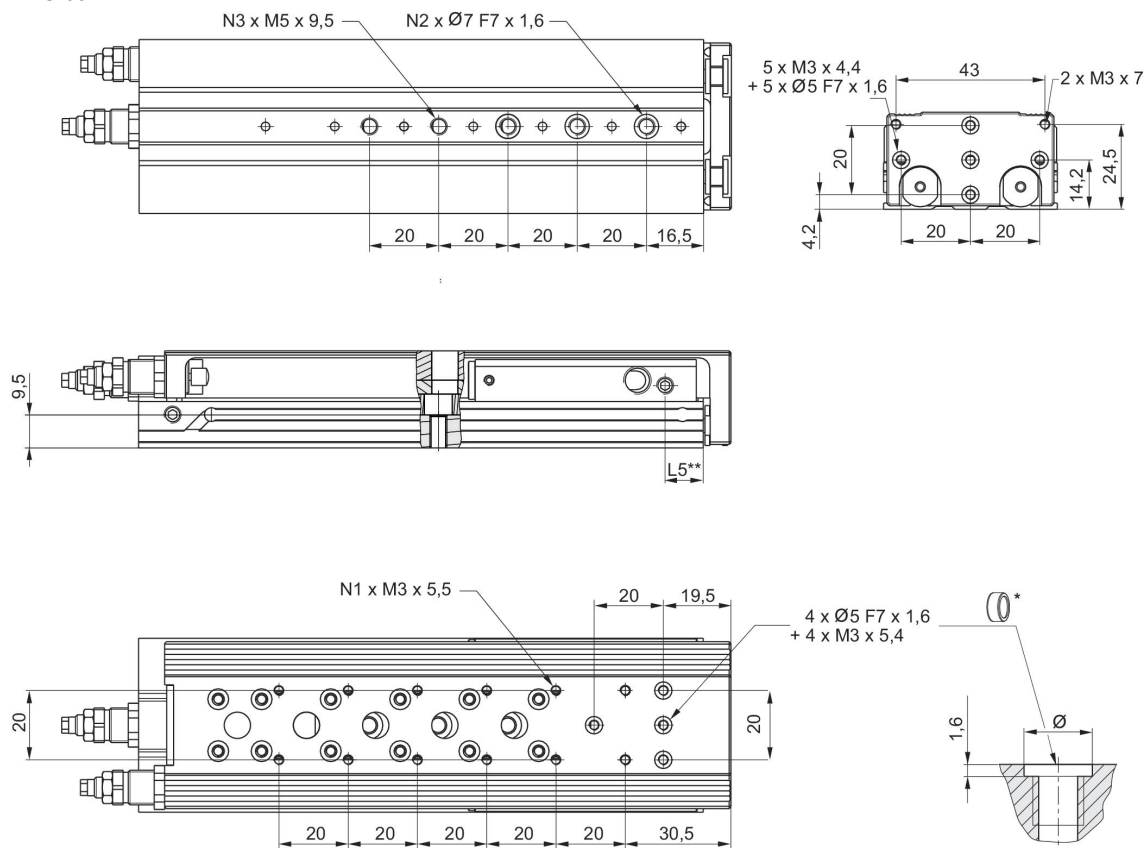

\* = Zentrierringe

\*\* Ø 8 hat eine andere Bezugsfläche.

Materialnummer	Kolben-Ø	Hub	N1	N2	N3	L5
R412019204	8	10	4	2	2	11
R412019205	8	20	4	2	2	11
R412019206	8	30	4	2	2	11
R412019207	8	40	6	2	2	11
R412019208	8	50	8	3	3	11
R412019209	8	80	12	3	5	11

## Abmessungen MSC-12

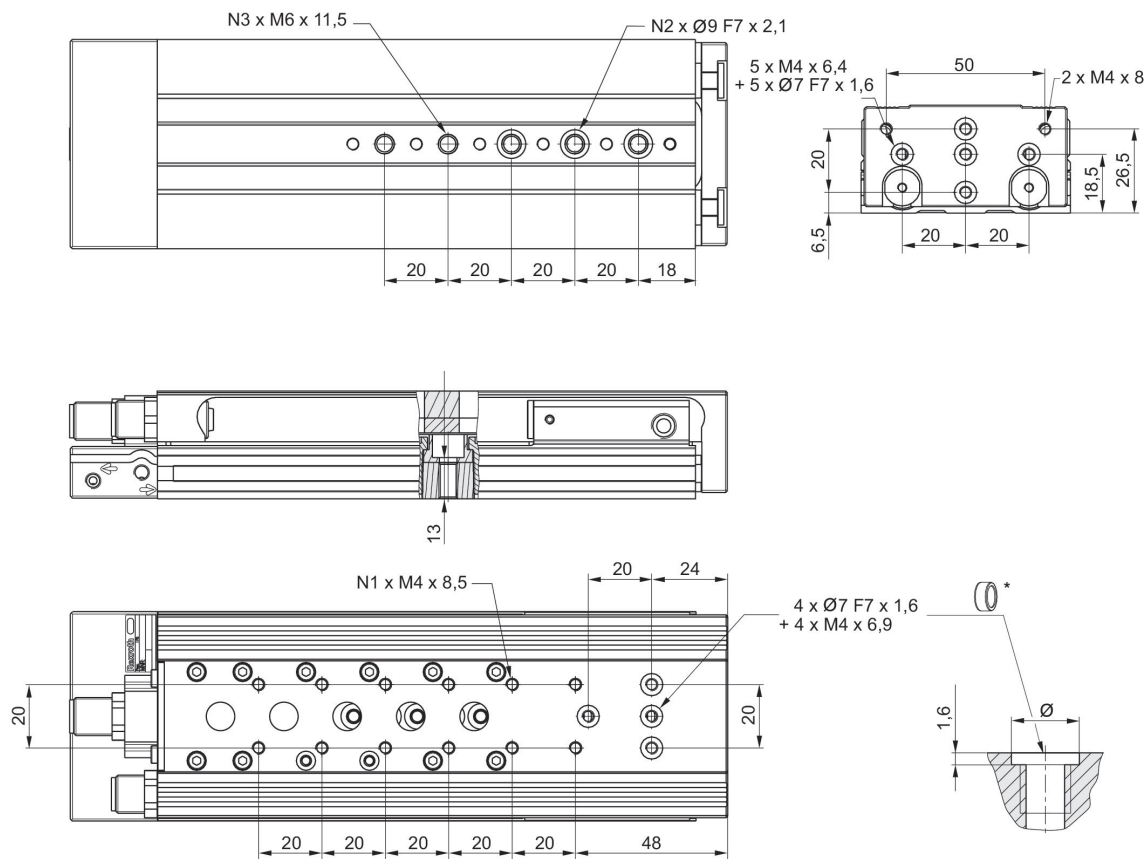

\* = Zentrierringe

Materialnummer	Kolben-Ø	Hub	N1	N2	N3
R412019190	12	10	4	2	2
R412019191	12	20	4	2	2
R412019192	12	30	4	2	2
R412019193	12	40	4	2	2
R412019194	12	50	6	3	3
R412019195	12	80	10	3	5
R412019196	12	100	12	3	5

## Abmessungen MSC-16

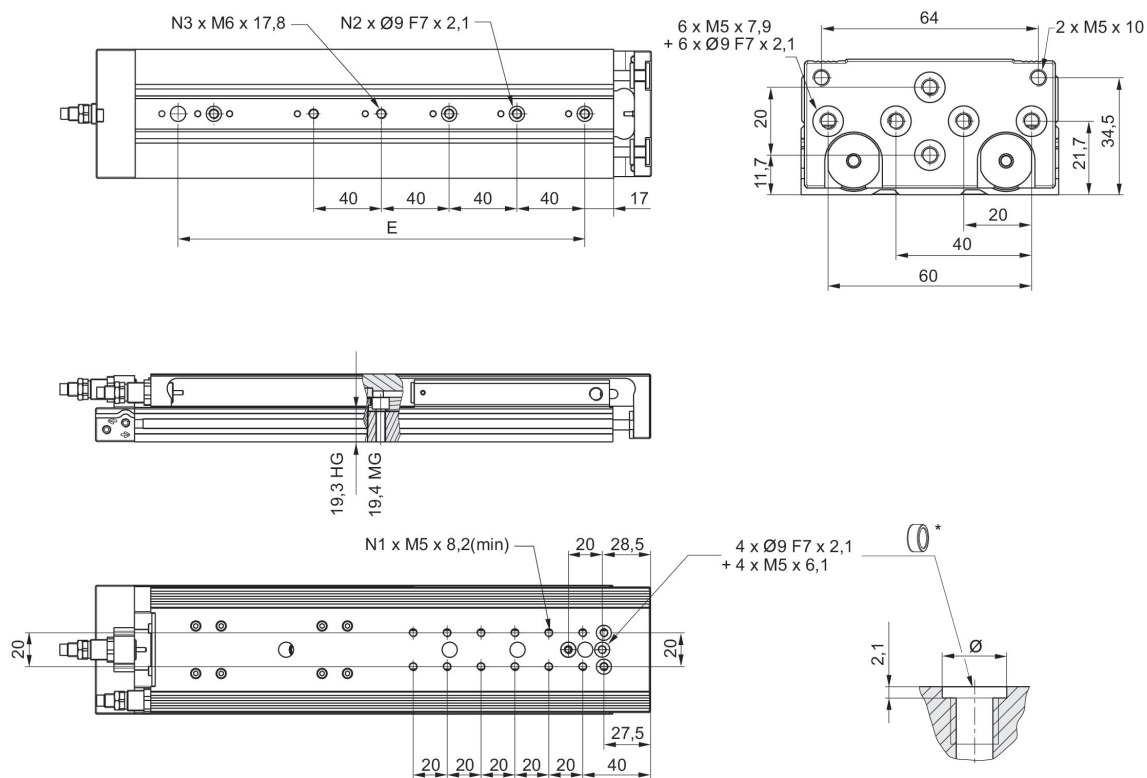

\* = Zentrierringe

Materialnummer	Kolben-Ø	Hub	E	N1	N2	N3
R480643801	16	10	-	4	2	2
R480643802	16	20	-	4	2	2
R480643803	16	30	-	4	2	2
R480643804	16	40	-	4	2	2
R480643805	16	50	-	6	2	2
R480643806	16	80	-	6	3	3
R480643807	16	100	-	8	3	3

Materialnummer	Kolben-Ø	Hub	E	N1	N2	N3
R412019175	16	125	200	12	4	5
R480643808	16	125	200	12	4	5
R412019188	16	125	200	12	4	5
R480640200	16	125	200	12	4	5
R412019176	16	150	240	12	4	5
R480643809	16	150	240	12	4	5
R412019189	16	150	240	12	4	5
R480640201	16	150	240	12	4	5

## Abmessungen MSC-20

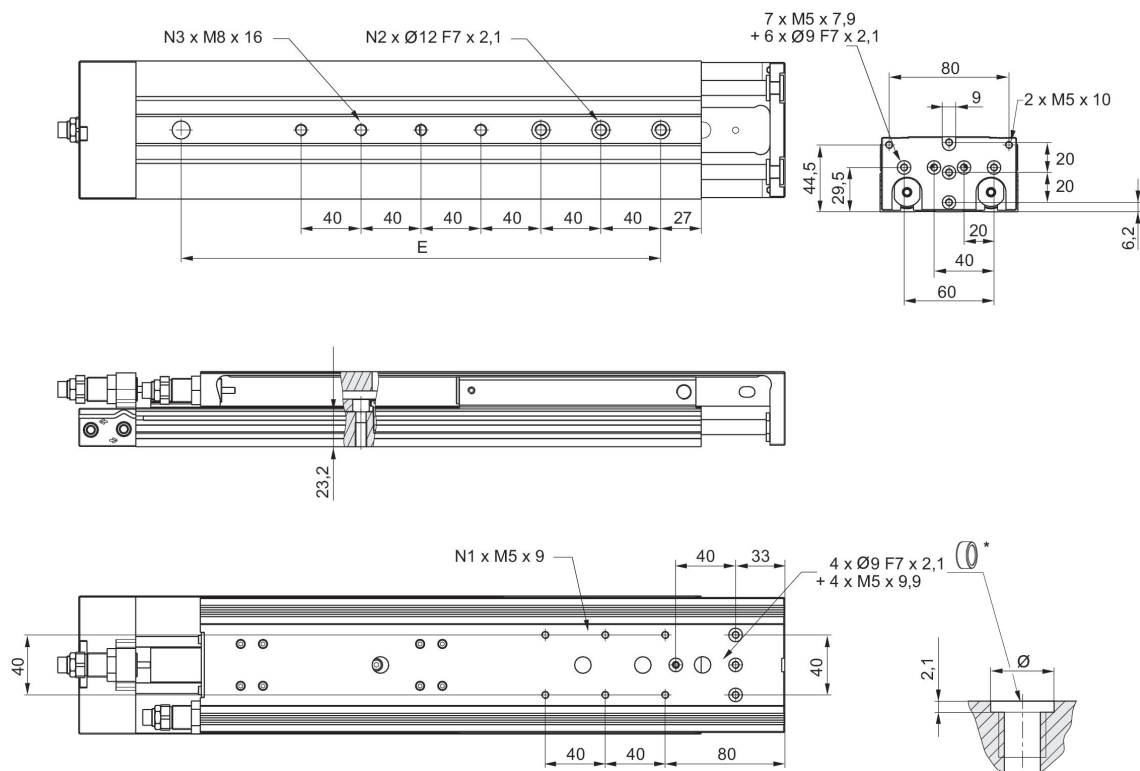

\* = Zentrierringe

Materialnummer	Kolben-Ø	Hub	E	N1	N2	N3
R412018910	20	10	-	2	2	2
R412018911	20	20	-	2	2	2
R412018912	20	30	-	2	2	2
R412018913	20	40	-	2	2	2
R412018914	20	50	-	2	2	2
R412018915	20	80	-	4	3	3
R412018916	20	100	-	4	3	3

Materialnummer	Kolben-Ø	Hub	E	N1	N2	N3
R412018917	20	125	200	6	4	5
R480643817	20	125	200	6	4	5
R412019005	20	125	200	6	4	5
R480640205	20	125	200	6	4	5
R412018918	20	150	240	6	4	5
R480643818	20	150	240	6	4	5
R412019006	20	150	240	6	4	5
R480640206	20	150	240	6	4	5
R412018919	20	200	320	6	4	7
R480643819	20	200	320	6	4	7
R412019007	20	200	320	6	4	7
R480640207	20	200	320	6	4	7

## Abmessungen MSC-25

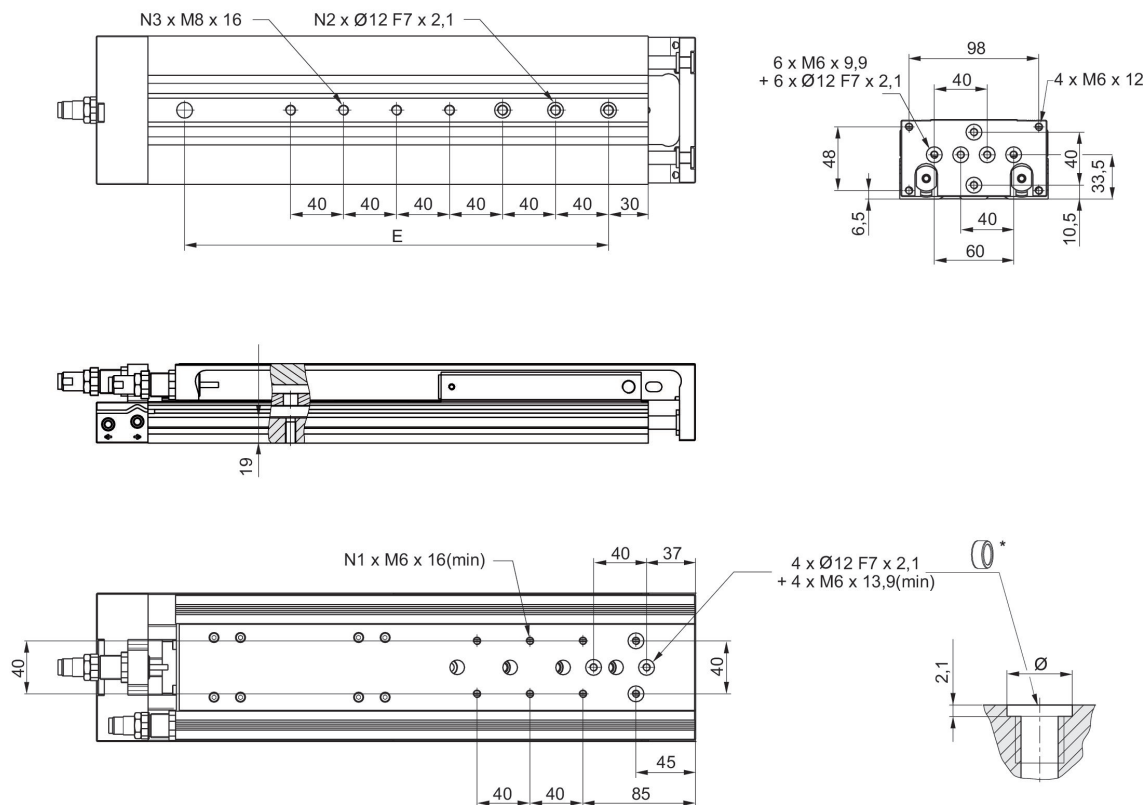

\* = Zentrierringe

Materialnummer	Kolben-Ø	Hub	E	N1	N2	N3
R480643820	25	10	-	2	2	2
R480643821	25	20	-	2	2	2
R480643822	25	30	-	2	2	2
R480643823	25	40	-	2	2	2
R480643824	25	50	-	4	2	2
R480643825	25	80	-	4	3	3
R480643826	25	100	-	4	3	3

Materialnummer	Kolben-Ø	Hub	E	N1	N2	N3
R412019030	25	125	200	4	4	5
R480643827	25	125	200	4	4	5
R412019041	25	125	200	4	4	5
R480640211	25	125	200	4	4	5
R412019031	25	150	240	6	4	5
R480643828	25	150	240	6	4	5
R412019042	25	150	240	6	4	5
R480640212	25	150	240	6	4	5
R412019032	25	200	320	6	4	7
R480643829	25	200	320	6	4	7
R412019043	25	200	320	6	4	7
R480640213	25	200	320	6	4	7

Tragfähigkeit

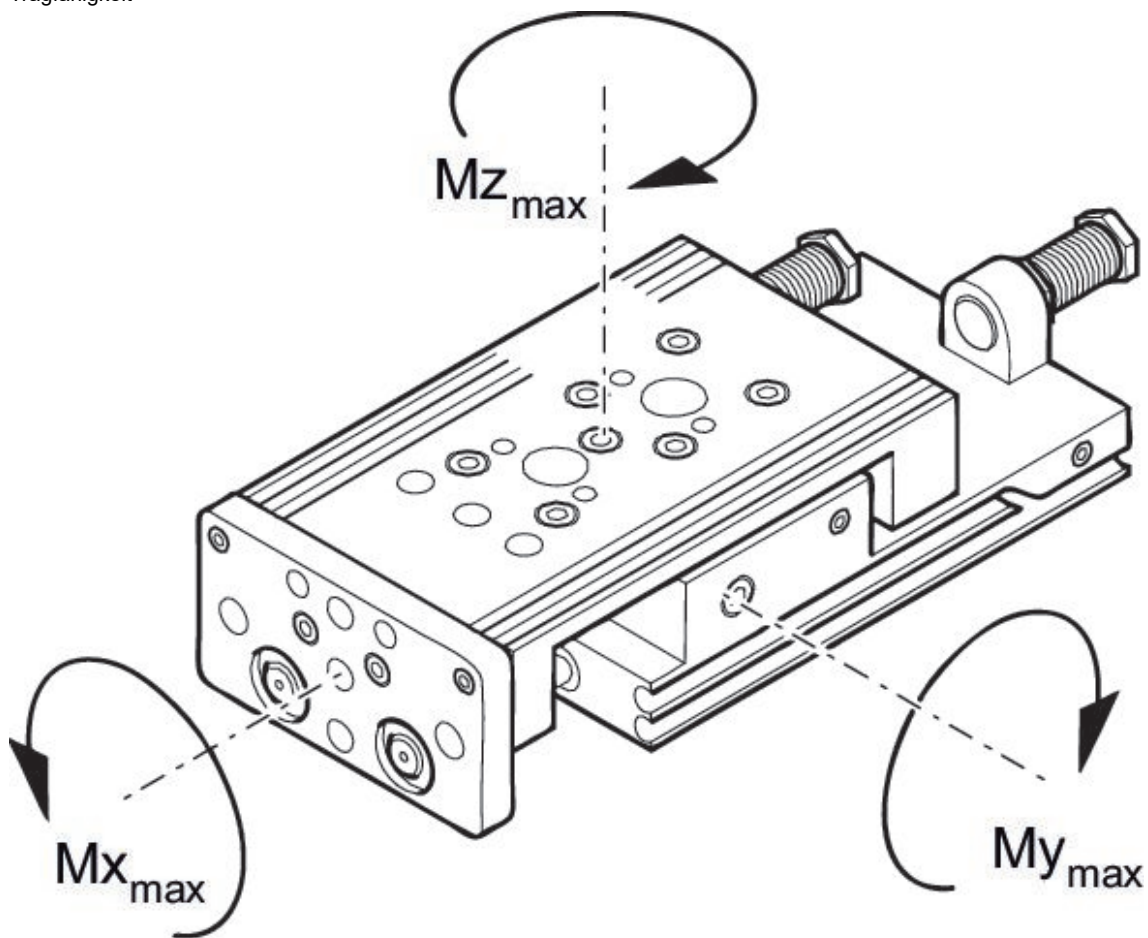

M = max. zulässiges Drehmoment

Korrekturfaktor (a)

Materialnummer	Kolben-Ø	S	a [mm]	d [mm]	$M_{x_{max}}$ [Nm]	$M_{y_{max}}$ [Nm]	$M_{z_{max}}$ [Nm]
R480643788	8	10	45	14	7	7	7
R480643789	8	20	50	14	7	7	7
R480643790	8	30	60	14	7	7	7
R480643791	8	40	70	14	7	7	7
R480643792	8	50	80	14	9	13	13
R480643793	8	80	125	14	13	25	25
R480643794	12	10	54.5	16	20	14	14
R480643795	12	20	59.5	16	20	14	14
R480643796	12	30	64.5	16	20	14	14
R480643797	12	40	74.5	16	20	14	14
R480643798	12	50	84.5	16	23	19	19
R480643799	12	80	125	16	33	32	32
R480643800	12	100	145	16	33	32	32
R480643801	16	10	55.5	15	35	25	25
R480643802	16	20	60.5	15	35	25	25
R480643803	16	30	65.5	15	35	25	25
R480643804	16	40	75.5	15	35	25	25
R480643805	16	50	85.5	15	38	29	29
R480643806	16	80	126	15	74	58	58
R480643807	16	100	146	15	74	58	58
R480643808	16	125	198.5	15	88	118	118
R480643809	16	150	223.5	15	88	119	119
R480643810	20	10	60.5	20	87	57	57
R480643811	20	20	65.5	20	87	57	57
R480643812	20	30	70.5	20	87	57	57
R480643813	20	40	80.5	20	87	57	57
R480643814	20	50	90.5	20	93	65	65
R480643815	20	80	130.5	20	116	99	99
R480643816	20	100	150.5	20	116	99	99
R480643817	20	125	201	20	126	136	136
R480643818	20	150	233.5	20	126	152	152
R480643819	20	200	296	20	126	179	179
R480643820	25	10	67.5	24	100	90	90
R480643821	25	20	72.5	24	100	90	90
R480643822	25	30	77.5	24	100	90	90
R480643823	25	40	87.5	24	100	90	90
R480643824	25	50	96.5	24	100	90	90
R480643825	25	80	137	24	110	129	129
R480643826	25	100	157	24	110	129	129
R480643827	25	125	201	24	145	180	180
R480643828	25	150	236.5	24	145	201	201
R480643829	25	200	299	24	145	236	236

S = Hub

- 1) Korrekturfaktor (a)
- 2) Korrekturfaktor (b)

## Gewicht beweglicher Teile [kg]

Kolben-Ø	S=10	S=20	S=30	S=40	S=50	S=80	S=100	S=125	S=150
8	0.14	0.14	0.155	0.165	0.195	0.265	–	–	–
12	0.255	0.255	0.26	0.28	0.315	0.403	0.46	–	–
16	0.375	0.375	0.375	0.4	0.45	0.615	0.65	0.725	0.7655
20	0.655	0.655	0.655	0.69	0.765	0.985	1.035	1.2	1.29
25	1	1	1	1.1	1.225	1.45	1.625	1.885	2.085

Kolben-Ø	S=200
8	–
12	–
16	–
20	1.54
25	2.445

S = Hub

Korrekturfaktor (a, d)

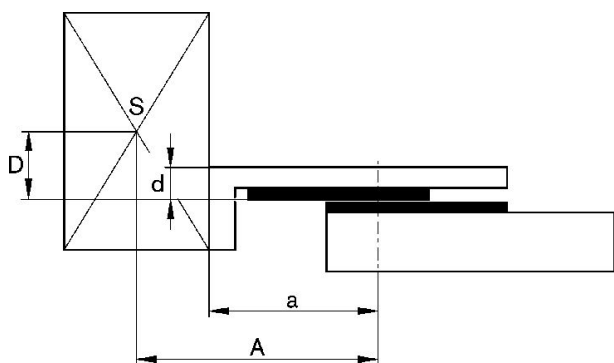

Korrekturfaktor (a, d)

horizontal

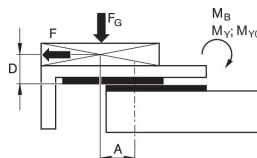

stat.	$M_{B0} = F_G \cdot A + F \cdot D$
dyn.	$M_B = F_G \cdot A$

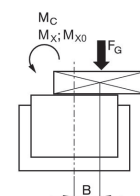

stat.	$M_{C0} = F_G \cdot B$
dyn.	$M_C = F_G \cdot B$

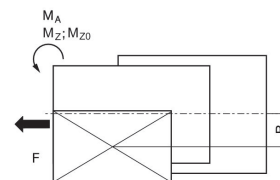

stat.	$M_{A0} = F \cdot B$
dyn.	$M_A = 0$

dyn.	$\frac{M_A}{M_1} + \frac{M_B}{M_2} + \frac{M_C}{M_3} \leq 1$
stat.	$\frac{M_{A0}}{M_{Z0}} + \frac{M_{B0}}{M_{Y0}} + \frac{M_{C0}}{M_{X0}} \leq 1$

$F = m \cdot a$   $FG = m \cdot g$   $a = 1250 \cdot V^2/H$   
 F = Verzögerungskraft [N]  $F_G$  = Gewichtskraft [N] m = Lastmasse [kg] a = Verzögerung [m/s<sup>2</sup>] g = Erdbeschleunigung 9,81 [m/s<sup>2</sup>] V = Geschwindigkeit H = Stoßdämpfers Hublänge [mm]

Korrekturfaktor (a, d)

vertikal

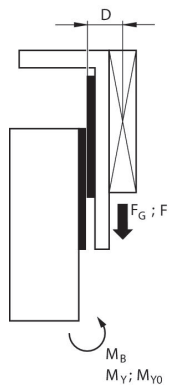

stat.	$M_{B0} = (F_G + F) \cdot D$
dyn.	$M_B = F_G \cdot D$

Maximal bewegte Masse

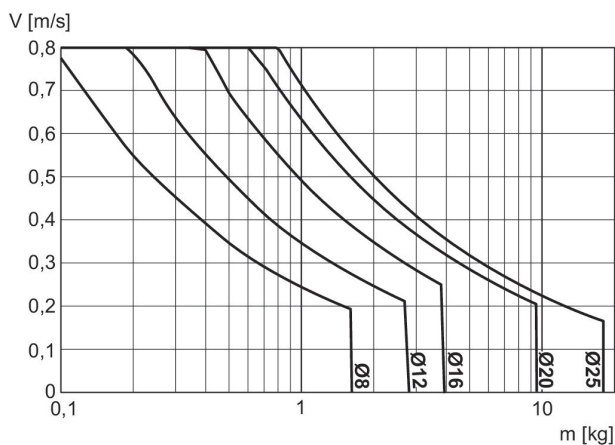

V = Geschwindigkeit [m/s]  
m = Masse

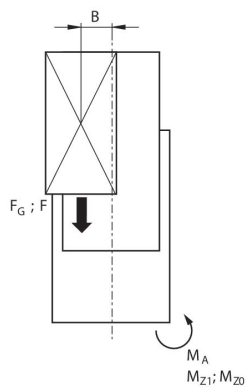

stat.	$M_{A0} = (F_G + F) \cdot B$
dyn.	$M_A = F_G \cdot B$

dyn.	$\frac{M_A}{M_1} + \frac{M_B}{M_2} \leq 1$
stat.	$\frac{M_{A0}}{M_{Z0}} + \frac{M_{B0}}{M_{Y0}} \leq 1$

$F = m \cdot a$   $F_G = m \cdot g$   $a = 1250 \cdot V^2 / H$   
 F = Verzögerungskraft [N]  $F_G$  = Gewichtskraft [N] m = Lastmasse [kg] a = Verzögerung [m/s<sup>2</sup>]  
 g = Erdbeschleunigung 9,81 [m/s<sup>2</sup>] V = Geschwindigkeit H = Stoßdämpfers Hublänge [mm]

**Korrekturfaktor erforderliche Geschwindigkeit ein- und ausfahrend, horizontal**

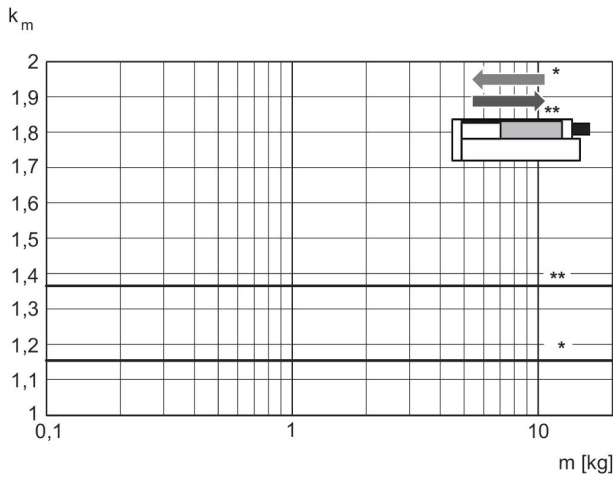

\* einfahrend  
\*\* ausfahrend  
 $V = s/1000 \cdot t \cdot km$   
V = Geschwindigkeit [m/s]  
S = Hub

**Korrekturfaktor erforderliche Geschwindigkeit ausfahrend, vertikal, nach oben**

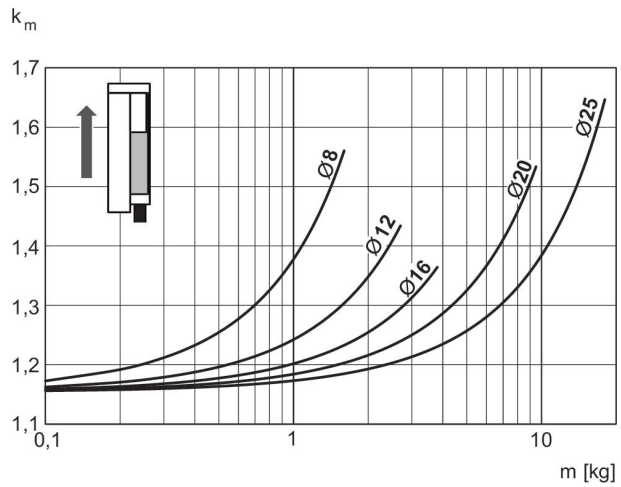

$V = s/1000 \cdot t \cdot km$   
V = Geschwindigkeit [m/s]  
S = Hub [mm]  
t = Zeit [s] für einen Hub  
m = Masse

**Korrekturfaktor erforderliche Geschwindigkeit einfahrend, vertikal, nach oben**

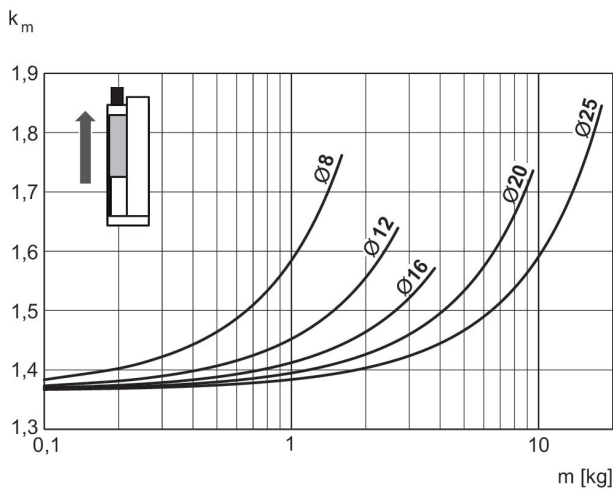

$V = s/1000 \cdot t \cdot km$   
V = Geschwindigkeit [m/s]  
S = Hub [mm]  
t = Zeit [s] für einen Hub  
m = Masse

**Korrekturfaktor erforderliche Geschwindigkeit einfahrend, vertikal, nach unten**

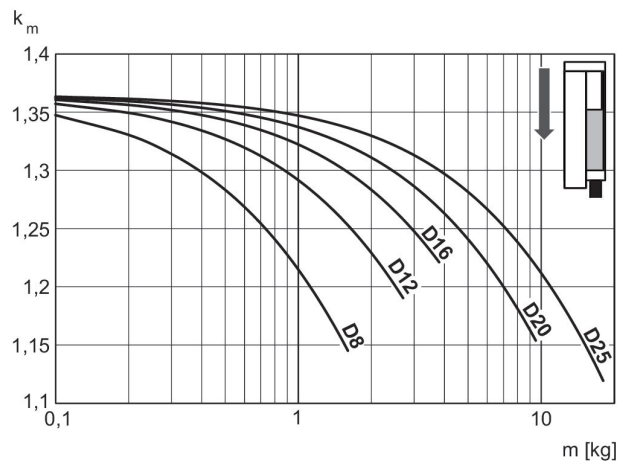

$V = s/1000 \cdot t \cdot km$   
V = Geschwindigkeit [m/s]  
S = Hub [mm]  
t = Zeit [s] für einen Hub  
m = Masse

**Korrekturfaktor erforderliche Geschwindigkeit ausfahrend, vertikal, nach unten**

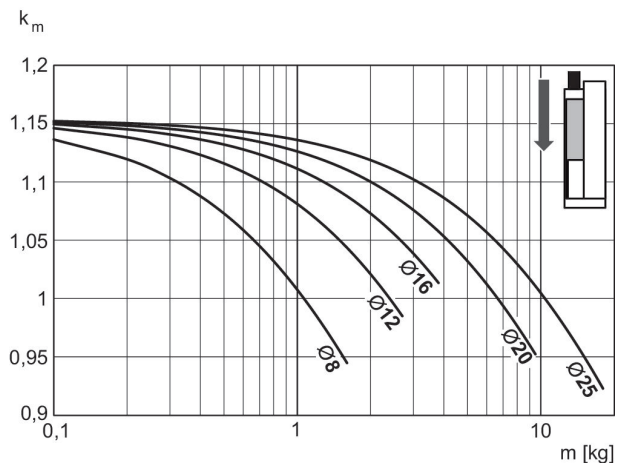

$V = s/1000 \cdot t \cdot km$   
 $V$  = Geschwindigkeit [m/s]  
 $S$  = Hub [mm]  
 $t$  = Zeit [s] für einen Hub  
 $m$  = Masse

**Faktor erreichbare Geschwindigkeit**

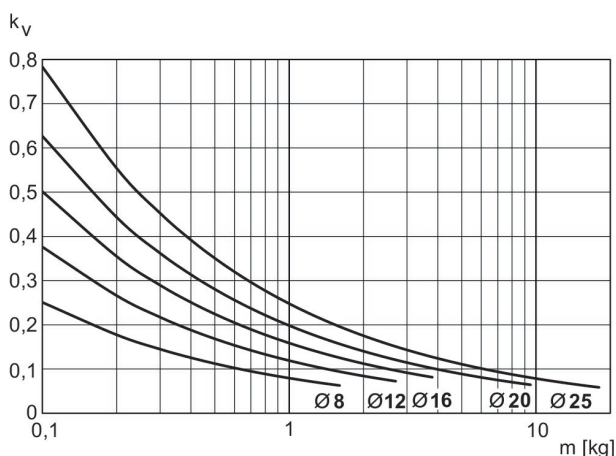

$V = \sqrt{s} \cdot kv$   
 $V$  = Geschwindigkeit [m/s]  
 $S$  = Hub [mm]  
 $m$  = Masse

### Minischlitten, Serie MSC-HG-HM

Wirkprinzip: doppelwirkend

Dämpfung: hydraulisch

Easy2Combine: fähig

: mit Magnetkolben

: mit Doppelkolben

: mit integrierter „High Performance“ Kugelschienenführung

Umgebungstemperatur min./max.: 0 °C ... 60 °C

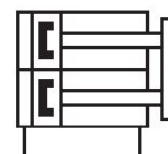

Kolben-Ø	8 mm	12 mm	16 mm	20 mm	25 mm
Anschlüsse	M5	M5	M5	G 1/8	G 1/8
Hub 20	R412019211	-	-	-	-
30	R412019212	R412019199	R412019183	R412019000	R412019036
40	R412019213	R412019200	R412019184	R412019001	R412019037
50	R412019214	R412019201	R412019185	R412019002	R412019038
80	R412019215	R412019202	R412019186	R412019003	R412019039
100	-	R412019203	R412019187	R412019004	R412019040
125	-	-	R412019188	R412019005	R412019041
150	-	-	R412019189	R412019006	R412019042
200	-	-	-	R412019007	R412019043

Kolben-Ø	8 mm	12 mm	16 mm	20 mm	25 mm
Kolbenkraft einfahrend, theoretisch	48 N	107 N	218 N	297 N	520 N
Kolbenkraft ausfahrend, theoretisch	63 N	143 N	253 N	396 N	619 N
Dämpfungsenergie	0.6 J	1 J	1.2 J	3.1 J	5.8 J
Dämpfungslänge	5 mm	7 mm	7 mm	10 mm	14 mm
Geschwindigkeit max.	0.8 m/s	0.8 m/s	0.8 m/s	0.8 m/s	0.8 m/s
Betriebsdruck min./max.	1.5 bar ... 10 bar	1 bar ... 10 bar	1 bar ... 10 bar	1 bar ... 10 bar	1 bar ... 10 bar

Abmessungen

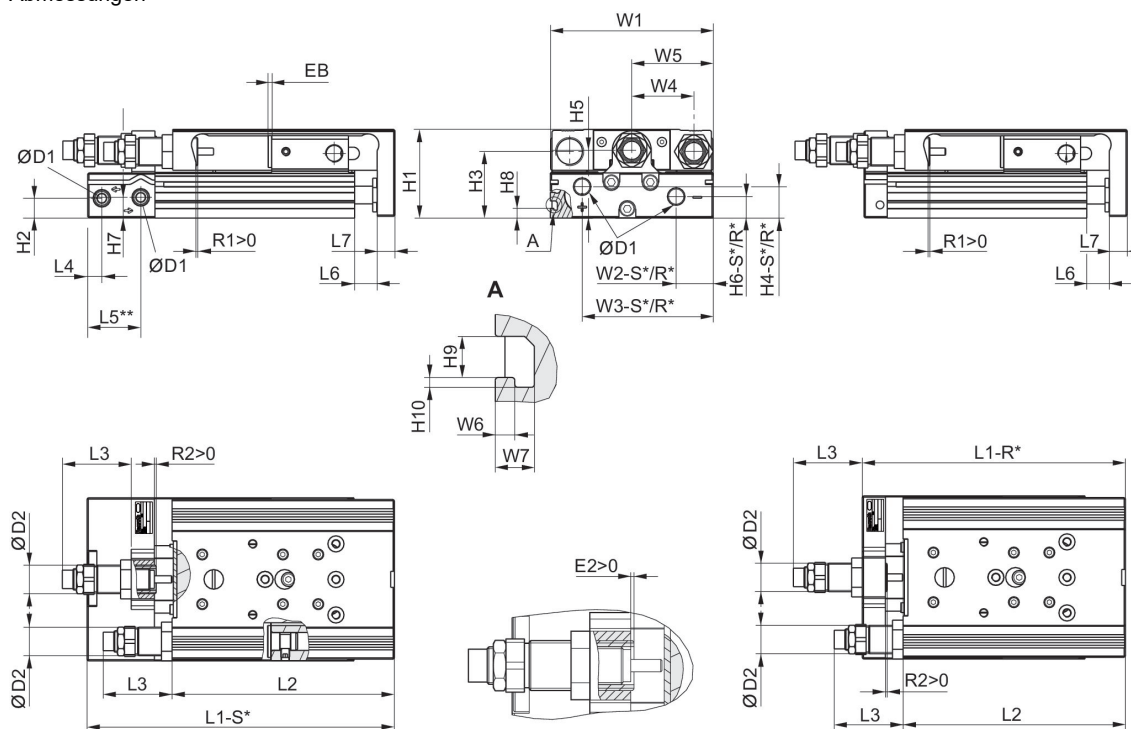

R\*: Bodenausführung mit Luftanschlüssen nur hinten  
S\*: Bodenausführung mit Luftanschlüssen hinten und seitlich  
\*\* Ø 8 hat eine andere Bezugsfläche.

Kolben-Ø	Ø D1	Ø D2	H1	H2	H3	H4-R	H4-S	H5	H6-R
8	M5	M10x1	28	9.6	20.5	-	7.5	19.5	-
12	M5	M12x1	34	5.7	25	11.2	11.2	24.5	5.7
16	M5	M12x1	40	7.2	29	12.2	12.2	31	7.7
20	G 1/8	M16x1,5	50	11.2	37.5	17.3	17.3	38.2	11.7
25	G 1/8	M18x1,5	60	14.2	44	15.5	22.9	46.5	13.2

Kolben-Ø	H6-S	H7	H8	H9	H10	L3 max.	L4	L5 2)	L6
8	5.5	18	-	-	-	31	9.8	-	1.9
12	5.7	8.3	-	-	-	46.7	7.2	22.5	2
16	7.7	11.2	-	-	-	44.9	6.5	17.7	2
20	12.2	11.7	5.5	4.2	1	48.9	8	30	2.1
25	21.7	16.2	6.9	5.2	1.5	67.7	9	31	2.1

Kolben-Ø	L7	R2	W1	W2-R	W2-S	W3-R	W3-S	W4	W5
8	6	4.1	50.2	-	19.3	-	30.5	18	W1/2
12	8	12	66	28.8	28.8	53	53	24.5	W1/2
16	10	10.4	76	31	31	60.5	60.5	30	W1/2
20	10	14	92	10	21	74	74	35	W1/2
25	12	16.2	112	11	14	92	92	44	W1/2

Kolben-Ø	W6	W7
8	–	–
12	–	–
16	–	–
20	2	4
25	2.5	4.8

## Hubabhängige Maße

Kolben-Ø	S=10 EB	S=20 EB	S=30 EB	S=40 EB	S=50 EB	S=80 EB	S=100 EB	S=125 EB	S=150 EB
8	12	2	2	2	2	2	–	–	–
12	22	12	2	2	2	2	2	–	–
6	22	12	2	2	2	2	2	2	2
20	22	12	2	2	2	2	2	2	2
25	22	12	2	2	2	2	2	2	2

Kolben-Ø	S=200 EB	S=10 L1-R	S=20 L1-R	S=30 L1-R	S=40 L1-R	S=50 L1-R	S=80 L1-R	S=100 L1-R	S=125 L1-R
8	–	–	–	–	–	–	–	–	–
12	–	99.3	99.3	99.3	109.3	124.3	170.3	190.3	–
6	–	101.8	101.8	101.8	111.8	126.8	172.8	192.8	281.3
20	2	112.9	112.9	112.9	122.9	137.9	182.9	202.9	287.4
25	2	126.1	126.1	126.1	136.1	149.1	195.1	215.1	292.1

Kolben-Ø	S=150 L1-R	S=200 L1-R	S=10 L1-S	S=20 L1-S	S=30 L1-S	S=40 L1-S	S=50 L1-S	S=80 L1-S	S=100 L1-S
8	–	–	80.7	80.7	90.7	100.7	120.7	170.7	–
12	–	–	116.2	116.2	116.2	126.2	141.2	187.2	207.2
6	306.3	–	112.7	112.7	112.7	122.7	137.7	183.7	203.7
20	327.4	402.4	137.8	137.8	137.8	147.8	162.8	207.8	227.8
25	332.1	407.1	149.8	149.8	149.8	159.8	172.8	218.8	238.8

Kolben-Ø	S=125 L1-S	S=150 L1-S	S=200 L1-S	S=10 L2	S=20 L2	S=30 L2	S=40 L2	S=50 L2	S=80 L2
8	–	–	–	73.5	73.5	83.5	93.5	113.5	163.5
12	–	–	–	88.8	88.8	88.8	98.8	113.8	159.8
6	292.2	317.2	–	90.4	90.4	90.4	100.4	115.4	161.4
20	312.3	352.3	427.3	100.5	100.5	100.5	110.5	125.5	170.5
25	315.8	355.8	430.8	111.5	111.5	111.5	121.5	134.5	180.5

Kolben-Ø	S=100 L2	S=125 L2	S=150 L2	S=200 L2	S=10 R1 max.	S=20 R1 max.	S=30 R1 max.	S=40 R1 max.	S=50 R1 max.
8	–	–	–	–	4.2	4.2	4.2	4.2	4.2
12	179.8	–	–	–	5.7	5.7	5.7	5.7	5.7
6	181.4	269.9	294.9	–	8.7	8.7	8.7	8.7	8.7
20	190.5	275	315	390	12.4	12.4	12.4	12.4	12.4
25	200.5	277.5	317.5	392.5	11.5	11.5	11.5	11.5	10.5

Kolben-Ø	S=80 R1 max.	S=100 R1 max.	S=125 R1 max.	S=150 R1 max.	S=200 R1 max.
8	4.2	-	-	-	-
12	5.7	5.7	-	-	-
6	8.7	8.7	8.7	8.7	-
20	12.4	12.4	12.4	12.4	12.4
25	11.5	11.5	11.5	11.5	11.5

## Abmessungen MSC-08

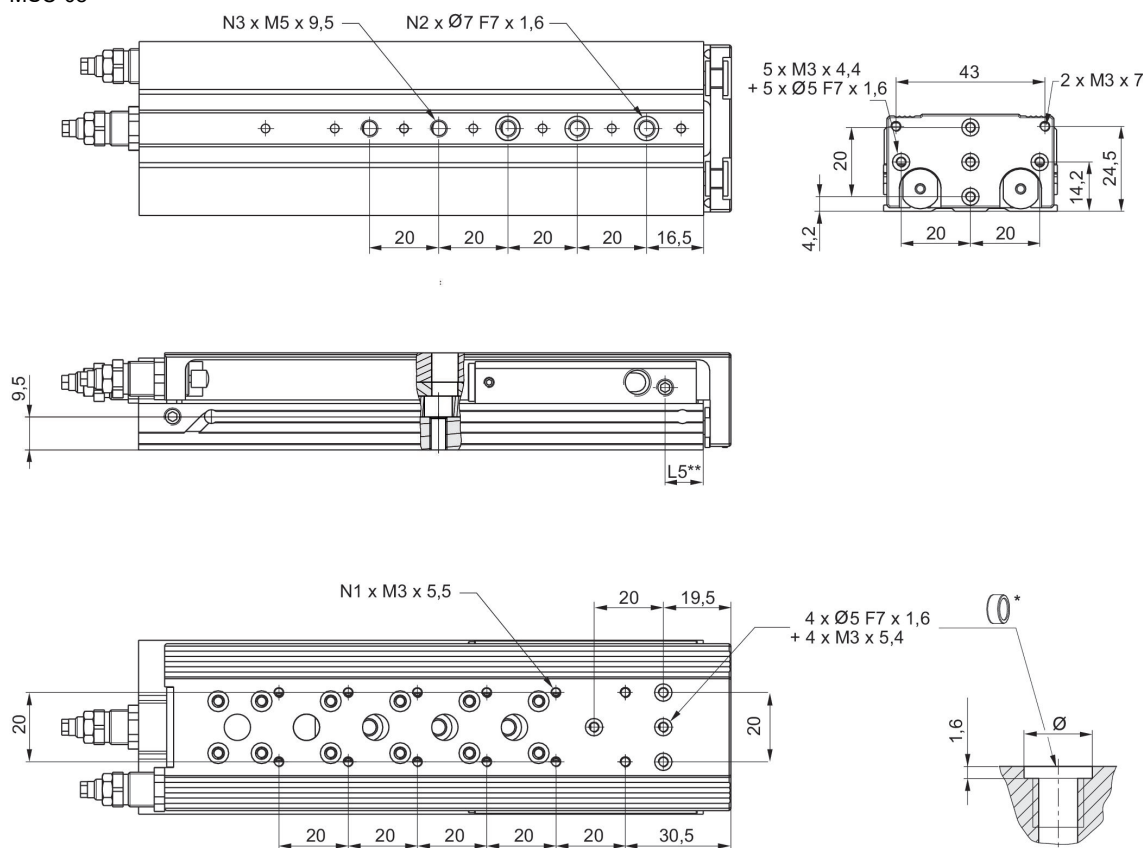

\* = Zentrierringe

\*\* Ø 8 hat eine andere Bezugsfläche.

Materialnummer	Kolben-Ø	Hub	N1	N2	N3	L5
R412019204	8	10	4	2	2	11
R412019205	8	20	4	2	2	11
R412019206	8	30	4	2	2	11
R412019207	8	40	6	2	2	11
R412019208	8	50	8	3	3	11
R412019209	8	80	12	3	5	11

## Abmessungen MSC-12

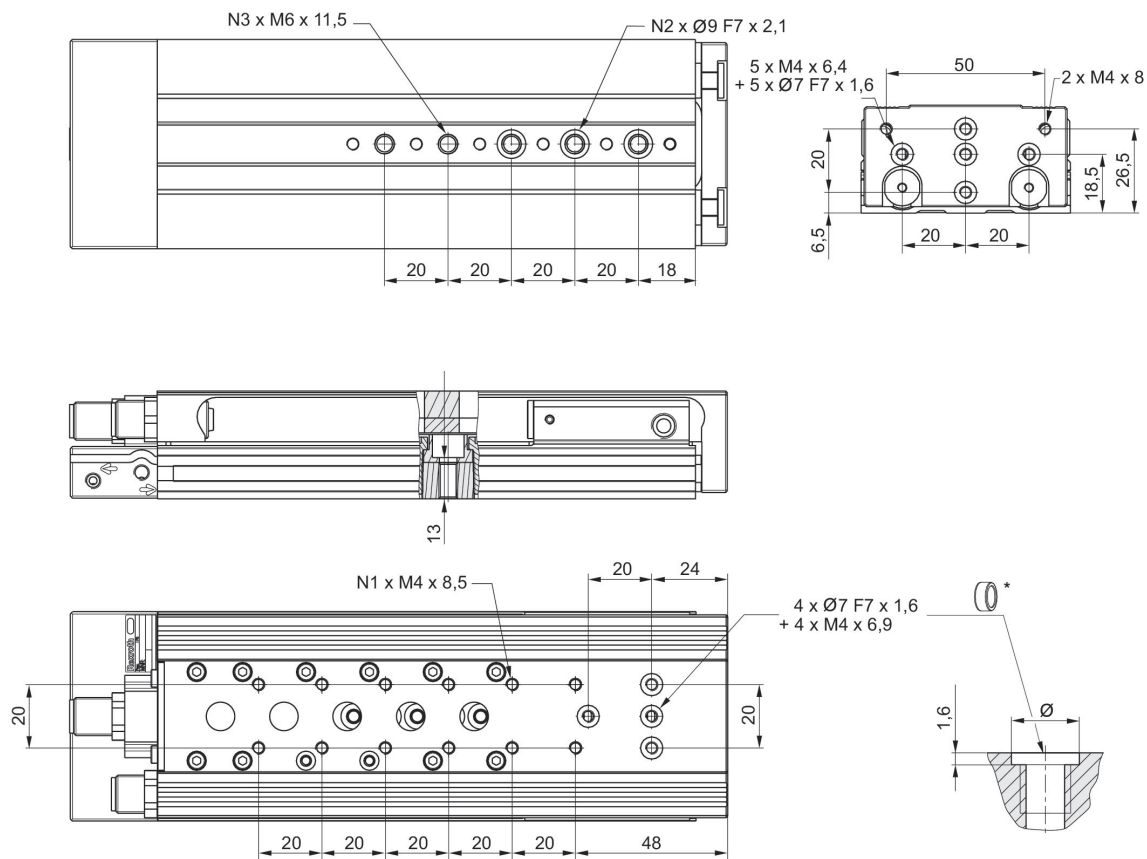

\* = Zentrierringe

Materialnummer	Kolben-Ø	Hub	N1	N2	N3
R412019190	12	10	4	2	2
R412019191	12	20	4	2	2
R412019192	12	30	4	2	2
R412019193	12	40	4	2	2
R412019194	12	50	6	3	3
R412019195	12	80	10	3	5
R412019196	12	100	12	3	5

Materialnummer	Kolben-Ø	Hub	N1	N2	N3
R480643794	12	10	4	2	2
R480643795	12	20	4	2	2
R480643796	12	30	4	2	2
R480643797	12	40	4	2	2
R480643798	12	50	6	3	3
R480643799	12	80	10	3	5
R480643800	12	100	12	3	5

Materialnummer	Kolben-Ø	Hub	N1	N2	N3
R412019190	12	10	4	2	2
R412019191	12	20	4	2	2
R412019192	12	30	4	2	2
R412019193	12	40	4	2	2
R412019194	12	50	6	3	3
R412019195	12	80	10	3	5
R412019196	12	100	12	3	5

## Abmessungen MSC-16

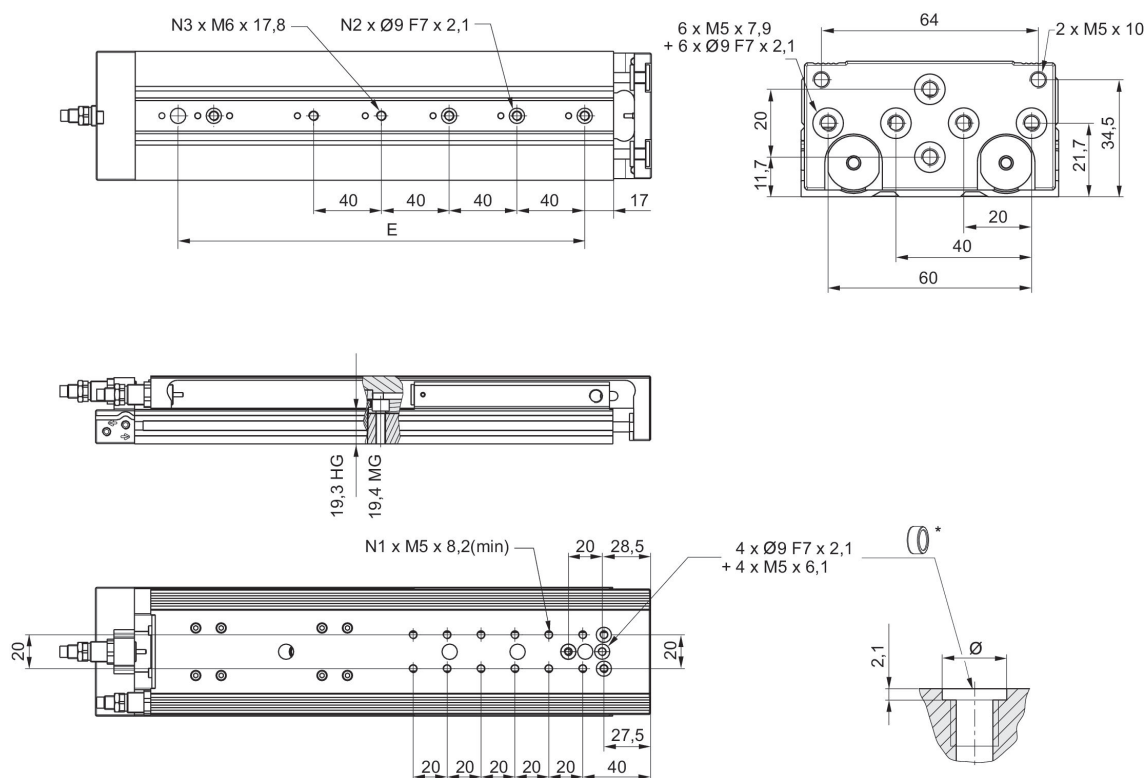

\* = Zentrierringe

Materialnummer	Kolben-Ø	Hub	E	N1	N2	N3
R412019175	16	125	200	12	4	5
R480643808	16	125	200	12	4	5
R412019188	16	125	200	12	4	5
R480640200	16	125	200	12	4	5
R412019176	16	150	240	12	4	5
R480643809	16	150	240	12	4	5
R412019189	16	150	240	12	4	5
R480640201	16	150	240	12	4	5

## Abmessungen MSC-20

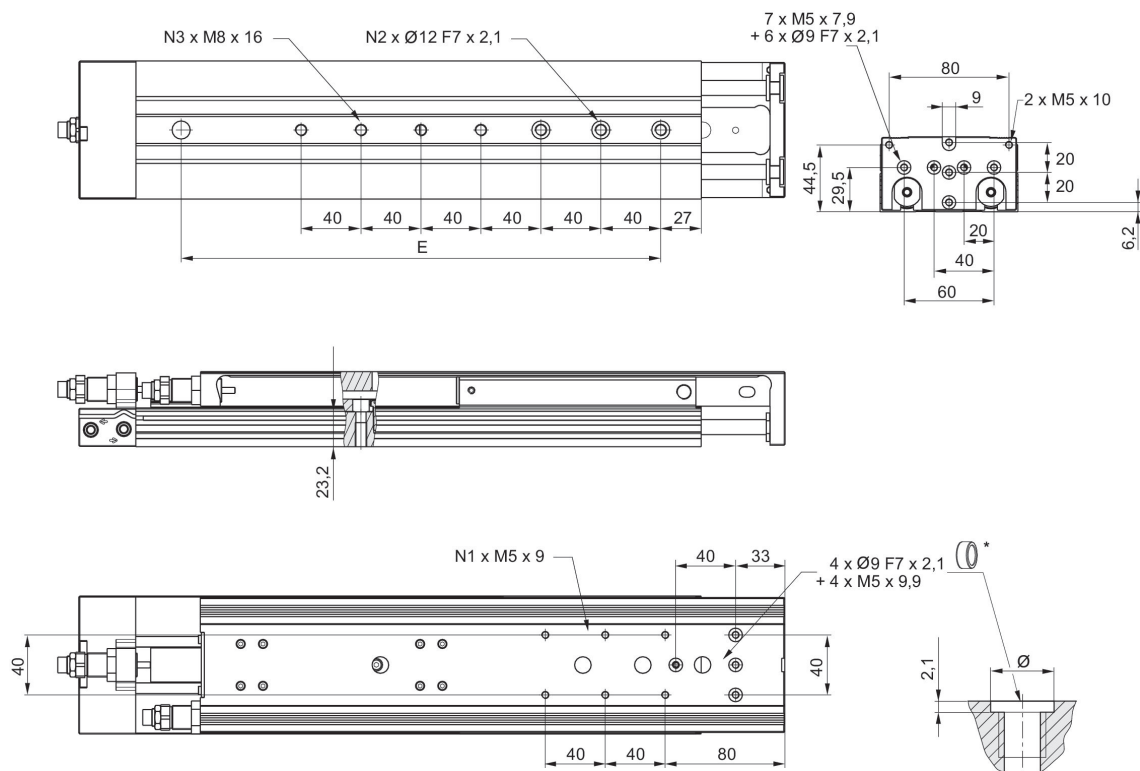

\* = Zentrierringe

Materialnummer	Kolben-Ø	Hub	E	N1	N2	N3
R412018917	20	125	200	6	4	5
R480643817	20	125	200	6	4	5
R412019005	20	125	200	6	4	5
R480640205	20	125	200	6	4	5
R412018918	20	150	240	6	4	5
R480643818	20	150	240	6	4	5
R412019006	20	150	240	6	4	5
R480640206	20	150	240	6	4	5
R412018919	20	200	320	6	4	7
R480643819	20	200	320	6	4	7
R412019007	20	200	320	6	4	7
R480640207	20	200	320	6	4	7

## Abmessungen MSC-25

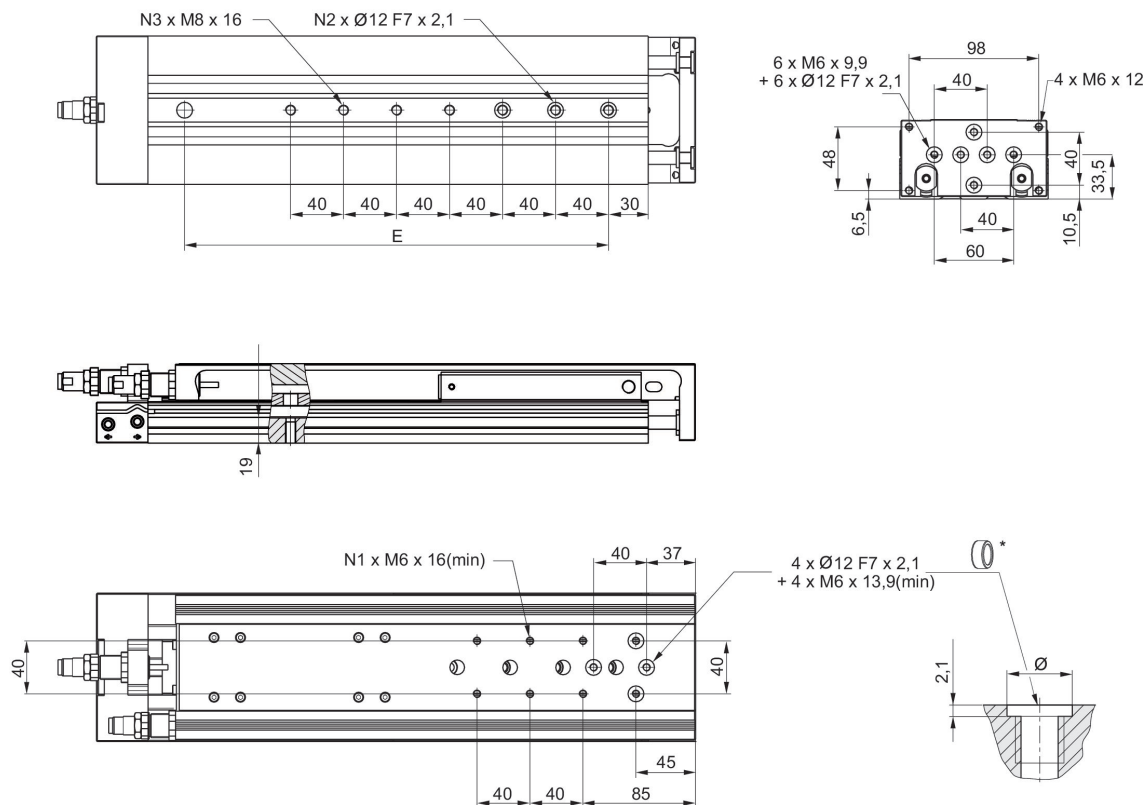

\* = Zentrierringe

Materialnummer	Kolben-Ø	Hub	E	N1	N2	N3
R412019030	25	125	200	4	4	5
R480643827	25	125	200	4	4	5
R412019041	25	125	200	4	4	5
R480640211	25	125	200	4	4	5
R412019031	25	150	240	6	4	5
R480643828	25	150	240	6	4	5
R412019042	25	150	240	6	4	5
R480640212	25	150	240	6	4	5
R412019032	25	200	320	6	4	7
R480643829	25	200	320	6	4	7
R412019043	25	200	320	6	4	7
R480640213	25	200	320	6	4	7

Tragfähigkeit

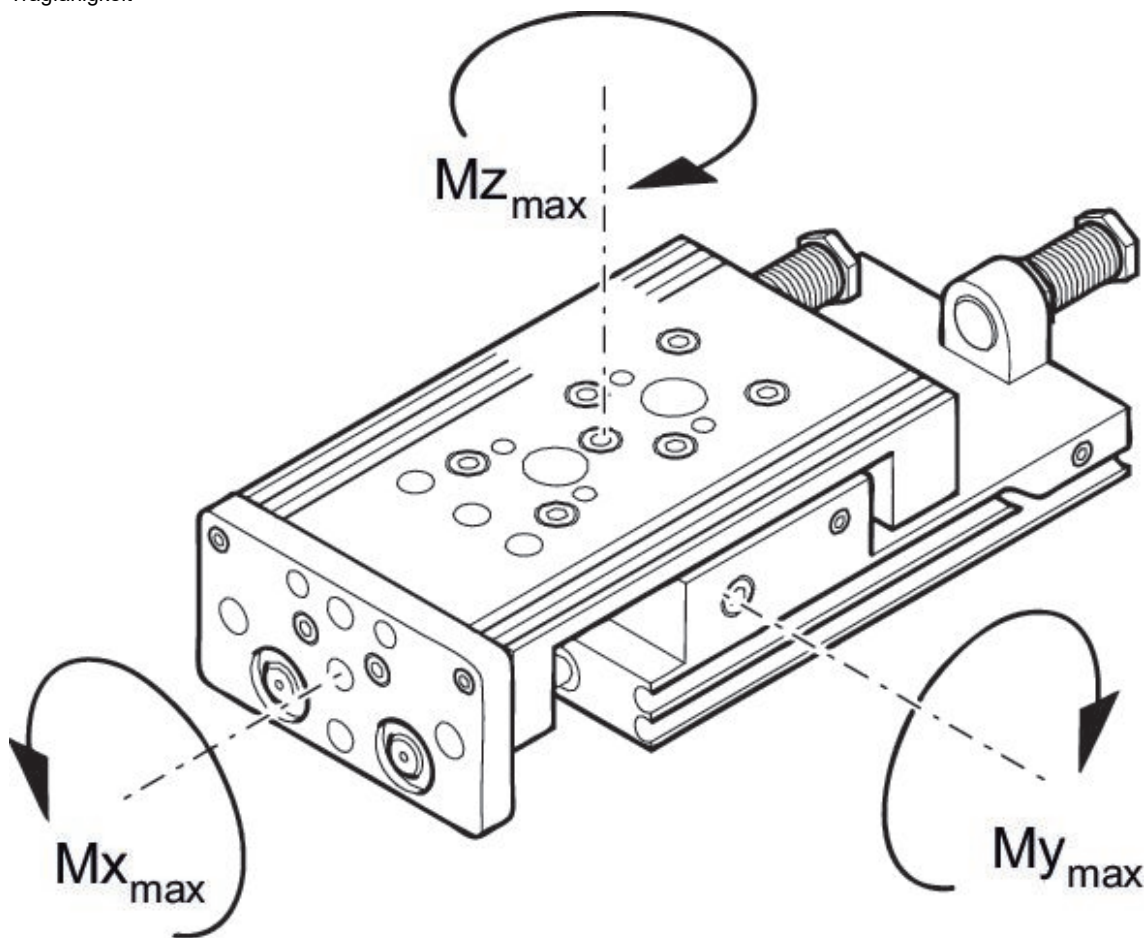

M = max. zulässiges Drehmoment

## Korrekturfaktor (a)

Materialnummer	Kolben-Ø	S	a [mm]	d [mm]	$M_{x_{max}}$ [Nm]	$M_{y_{max}}$ [Nm]	$M_{z_{max}}$ [Nm]
R412019211	8	20	50	14	7	7	7
R412019212	8	30	60	14	7	7	7
R412019213	8	40	70	14	7	7	7
R412019214	8	50	80	14	9	13	13
R412019215	8	80	125	14	13	25	25
R412019199	12	30	64.5	16	20	14	14
R412019200	12	40	74.5	16	20	14	14
R412019201	12	50	84.5	16	23	19	19
R412019202	12	80	125	16	33	32	32
R412019203	12	100	145	16	33	32	32
R412019183	16	30	65.5	15	35	25	25
R412019184	16	40	75.5	15	35	25	25
R412019185	16	50	85.5	15	38	29	29
R412019186	16	80	126	15	74	58	58
R412019187	16	100	146	15	74	58	58
R412019188	16	125	198.5	15	88	118	118
R412019189	16	150	223.5	15	88	119	119
R412019000	20	30	70.5	20	87	57	57
R412019001	20	40	80.5	20	87	57	57
R412019002	20	50	90.5	20	93	65	65
R412019003	20	80	130.5	20	116	99	99
R412019004	20	100	150.5	20	116	99	99
R412019006	20	150	233.5	20	126	152	152
R412019007	20	200	296	20	126	179	179
R412019036	25	30	77.5	24	100	90	90
R412019037	25	40	87.5	24	100	90	90
R412019038	25	50	96.5	24	100	90	90
R412019039	25	80	137	24	110	129	129
R412019040	25	100	157	24	110	129	129
R412019041	25	125	201	24	145	180	180
R412019042	25	150	236.5	24	145	201	201
R412019043	25	200	299	24	145	236	236

S = Hub

### Gewicht beweglicher Teile [kg]

Kolben-Ø	S=10	S=20	S=30	S=40	S=50	S=80	S=100	S=125	S=150
8	0.14	0.14	0.155	0.165	0.195	0.265	–	–	–
12	0.255	0.255	0.26	0.28	0.315	0.403	0.46	–	–
16	0.375	0.375	0.375	0.4	0.45	0.615	0.65	0.725	0.765
20	0.655	0.655	0.655	0.69	0.765	0.985	1.035	1.2	1.29
25	1	1	1	1.1	1.225	1.45	1.625	1.885	2.085

Kolben-Ø	S=200
8	–
12	–
16	–
20	1.54
25	2.445

#### Korrekturfaktor (a, d)

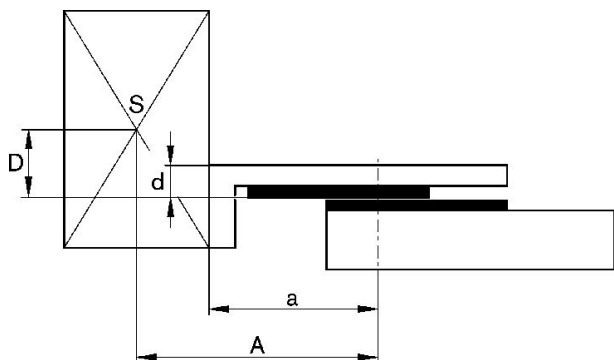

#### Korrekturfaktor (a, d)

##### horizontal

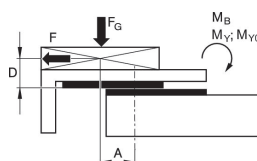

stat.	$M_{B0} = F_G \cdot A + F \cdot D$
dyn.	$M_B = F_G \cdot A$

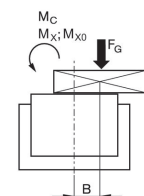

stat.	$M_{C0} = F_G \cdot B$
dyn.	$M_C = F_G \cdot B$

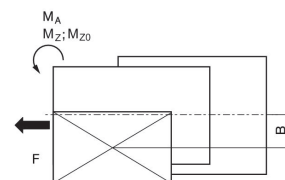

stat.	$M_{A0} = F \cdot B$
dyn.	$M_A = 0$

dyn.	$\frac{M_A}{M_1} + \frac{M_B}{M_2} + \frac{M_C}{M_3} \leq 1$
stat.	$\frac{M_{A0}}{M_{Z0}} + \frac{M_{B0}}{M_{Y0}} + \frac{M_{C0}}{M_{X0}} \leq 1$

$F = m \cdot a$   $F_G = m \cdot g$   $a = 1250 \cdot V^2 / H$   
 F = Verzögerungskraft [N]  $F_G$  = Gewichtskraft [N] m = Lastmasse [kg] a = Verzögerung [m/s<sup>2</sup>] g = Erdbeschleunigung 9,81 [m/s<sup>2</sup>] V = Geschwindigkeit H = Stoßdämpfers Hublänge [mm]

Korrekturfaktor (a, d)

vertikal

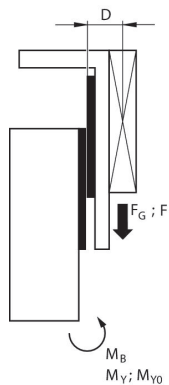

stat.	$M_{B0} = (F_G + F) \cdot D$
dyn.	$M_B = F_G \cdot D$

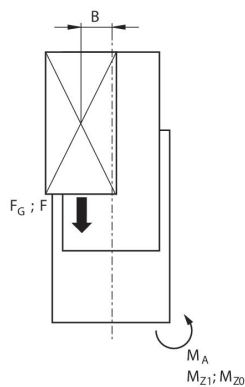

stat.	$M_{A0} = (F_G + F) \cdot B$
dyn.	$M_A = F_G \cdot B$

dyn.	$\frac{M_A}{M_1} + \frac{M_B}{M_2} \leq 1$
stat.	$\frac{M_{A0}}{M_{Z0}} + \frac{M_{B0}}{M_{Y0}} \leq 1$

$F = m \cdot a$   $F_G = m \cdot g$   $a = 1250 \cdot V^2 / H$   
 $F =$  Verzögerungskraft [N]  $F_G =$  Gewichtskraft [N]  $m =$  Lastmasse [kg]  $a =$  Verzögerung [m/s<sup>2</sup>]  $g =$  Erdbeschleunigung 9,81 [m/s<sup>2</sup>]  $V =$  Geschwindigkeit H = Stoßdämpfers Hublänge [mm]

Minimale und maximale bewegte Masse

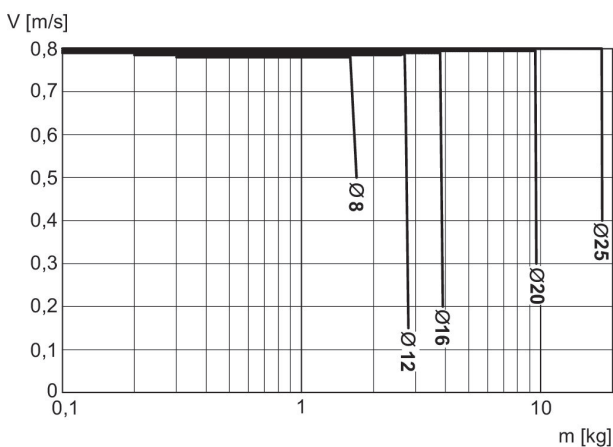

V = Geschwindigkeit [m/s]  
m = Masse

**Korrekturfaktor erforderliche Geschwindigkeit ein- und ausfahrend, horizontal**

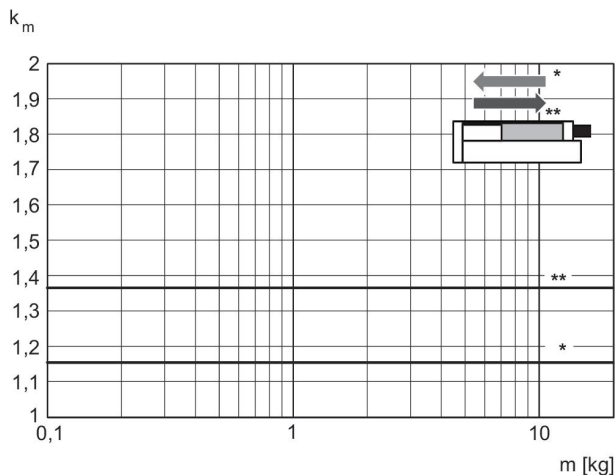

\* einfahrend  
\*\* ausfahrend  
 $V = s/1000 \cdot t \cdot km$   
V = Geschwindigkeit [m/s]  
S = Hub

**Max. zusätzlich bewegte Masse - horizontal**

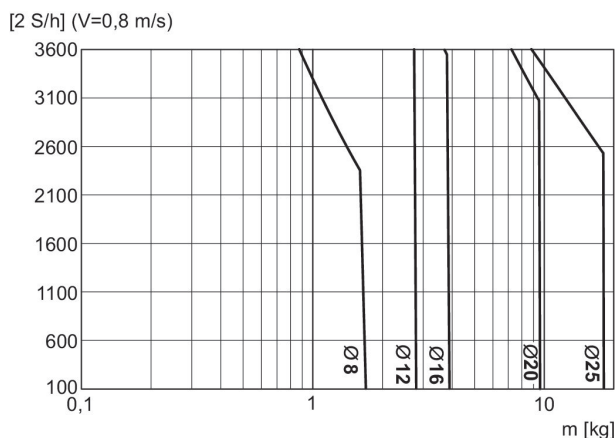

S = Hub [mm]  
2 x S = 1 Zyklus  
V = Geschwindigkeit [m/s]  
m = Masse

**Max. zusätzlich bewegte Masse - vertikal**

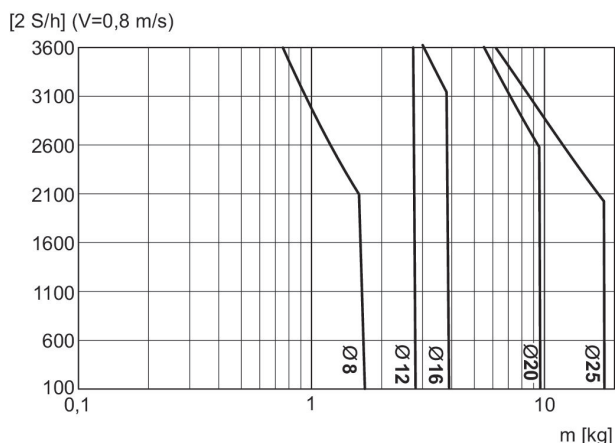

S = Hub [mm]  
2 x S = 1 Zyklus  
V = Geschwindigkeit [m/s]  
m = Masse

**Korrekturfaktor erforderliche Geschwindigkeit ausfahrend, vertikal, nach oben**

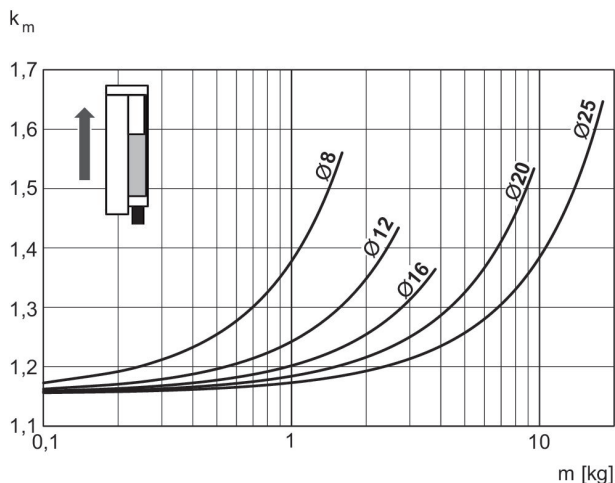

$V = s/1000 \cdot t \cdot km$   
V = Geschwindigkeit [m/s]  
S = Hub [mm]  
t = Zeit [s] für einen Hub  
m = Masse

**Korrekturfaktor erforderliche Geschwindigkeit einfahrend, vertikal, nach oben**

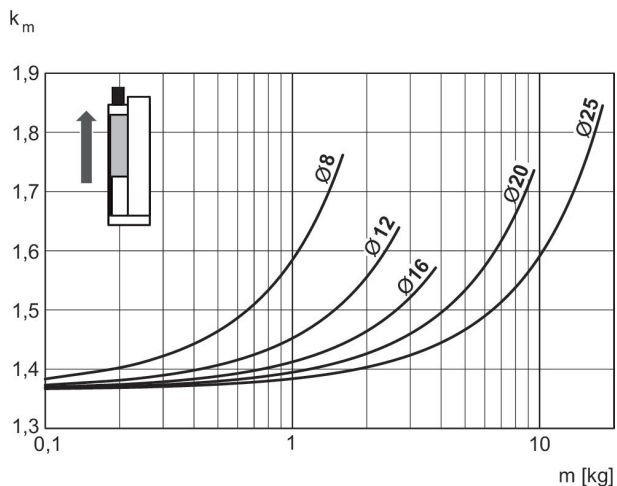

$V = s/1000 \cdot t \cdot km$   
 V = Geschwindigkeit [m/s]  
 S = Hub [mm]  
 t = Zeit [s] für einen Hub  
 m = Masse

**Korrekturfaktor erforderliche Geschwindigkeit einfahrend, vertikal, nach unten**

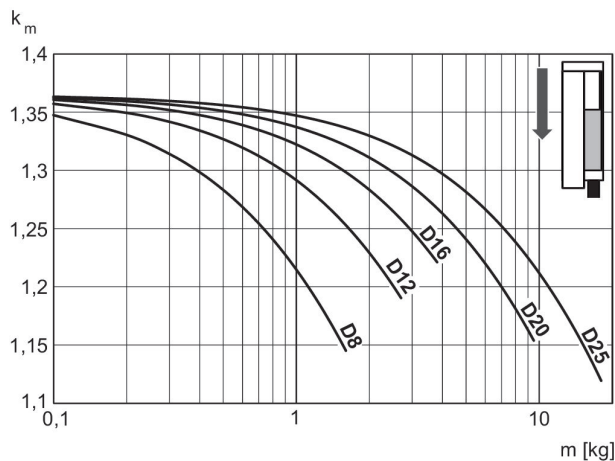

$V = s/1000 \cdot t \cdot km$   
 V = Geschwindigkeit [m/s]  
 S = Hub [mm]  
 t = Zeit [s] für einen Hub  
 m = Masse

**Korrekturfaktor erforderliche Geschwindigkeit ausfahrend, vertikal, nach unten**

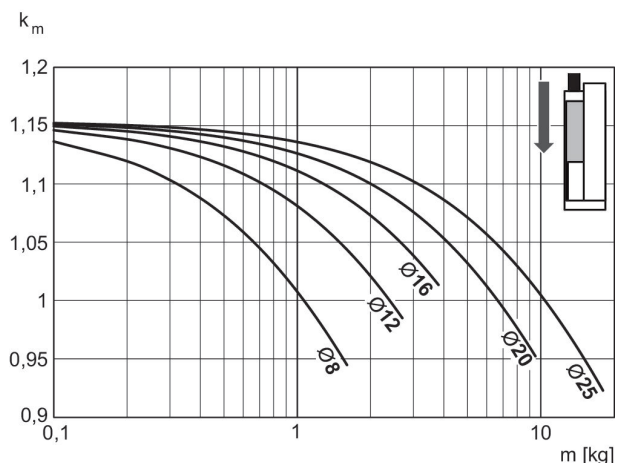

$V = s/1000 \cdot t \cdot km$   
 V = Geschwindigkeit [m/s]  
 S = Hub [mm]  
 t = Zeit [s] für einen Hub  
 m = Masse

**Faktor erreichbare Geschwindigkeit**

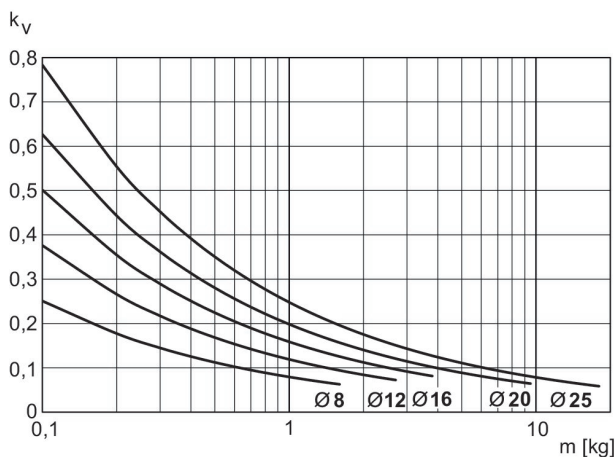

$V = \sqrt{s \cdot kv}$   
 V = Geschwindigkeit [m/s]  
 S = Hub [mm]  
 m = Masse

### Minischlitten, Serie MSC-HG-PM/PE

Wirkprinzip: doppeltwirkend

Dämpfung: pneumatisch

Easy2Combine: fähig

: mit Magnetkolben

: mit Doppelkolben

: mit integrierter „High Performance“ Kugelschienenführung

Umgebungstemperatur min./max.: 0 °C ... 60 °C

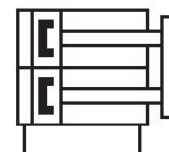

Kolben-Ø	16 mm	20 mm	25 mm
Anschlüsse	M5	G 1/8	G 1/8
Hub 50	R480640197	R480640202	R480640208
80	R480640198	R480640203	R480640209
100	R480640199	R480640204	R480640210
125	R480640200	R480640205	R480640211
150	R480640201	R480640206	R480640212
200	-	R480640207	R480640213

Kolben-Ø	16 mm	20 mm	25 mm
Kolbenkraft einfahrend, theoretisch	218 N	297 N	520 N
Kolbenkraft ausfahrend, theoretisch	182 N	269 N	421 N
Dämpfungsenergie	0.06 J	1.2 J	1.6 J
Dämpfungslänge	7 mm	7 mm	7 mm
Geschwindigkeit max.	0.8 m/s	0.8 m/s	0.8 m/s
Betriebsdruck min./max.	3 bar ... 10 bar	3 bar ... 10 bar	2 bar ... 10 bar

Abmessungen

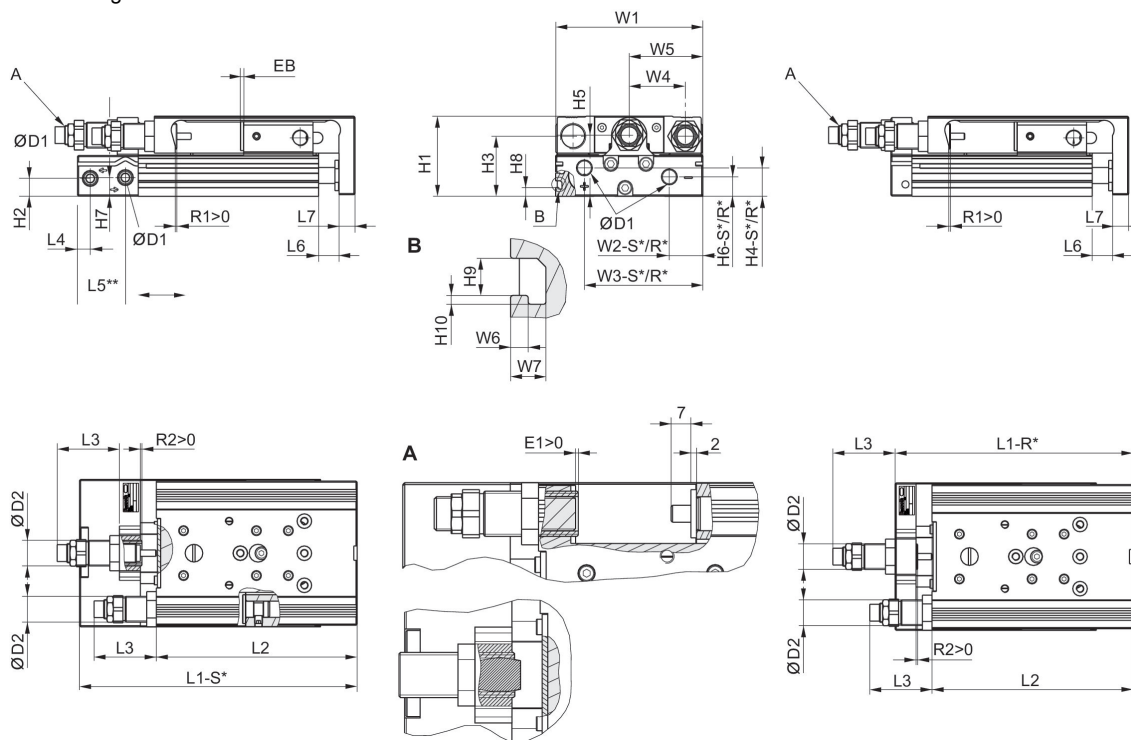

R\*: Bodenausführung mit Luftanschlüssen nur hinten  
S\*: Bodenausführung mit Luftanschlüssen hinten und seitlich

Abmessungen

Kolben-Ø	Ø D1	Ø D2	H1	H2	H3	H4-R	H4-S	H5	H6-R
16	M5	M12x1	40	7.2	29	12.2	12.2	31	7.7
20	G 1/8	M16x1,5	50	11.2	37.5	17.3	17.3	38.2	11.7
25	G 1/8	M18x1,5	60	14.2	44	15.5	22.9	46.5	13.2

Kolben-Ø	H6-S	H7	H8	H9	H10	L3 1) max.	L3 2) max.	L4	L5 3)
16	7.7	11.2	-	-	-	12	47	6.5	17.7
20	12.2	11.7	5.5	4.2	1	15	57	8	30
25	21.7	16.2	6.9	5.2	1.5	15	62	9	31

Kolben-Ø	L6	L7	R2	W1	W2-R	W2-S	W3-R	W3-S	W4
16	2	10	3	76	31	31	60.5	60.5	30
20	2.1	10	3	92	10	21	74	74	35
25	2.1	12	3	112	11	14	92	92	44

Kolben-Ø	W5	W6	W7
16	W1/2	-	-
20	W1/2	2	4
25	W1/2	2.5	4.8

## Hubabhängige Maße

Kolben-Ø	S=50 EB	S=80 EB	S=100 EB	S=125 EB	S=150 EB	S=200 EB	S=50 L1-R	S=80 L1-R	S=100 L1-R
16	2	2	2	2	2	–	126.8	172.8	192.8
20	2	2	2	2	2	2	137.9	182.9	202.9
25	2	2	2	2	2	2	149.1	195.1	215.1

Kolben-Ø	S=125 L1-R	S=150 L1-R	S=200 L1-R	S=50 L1-S	S=80 L1-S	S=100 L1-S	S=125 L1-S	S=150 L1-S	S=200 L1-S
16	281.3	306.3	–	137.7	183.7	203.7	292.2	317.2	–
20	287.4	327.4	402.4	162.8	207.8	227.8	312.3	352.3	427.3
25	292.1	332.1	407.1	172.8	218.8	238.8	315.8	355.8	430.8

Kolben-Ø	S=50 L2	S=80 L2	S=100 L2	S=125 L2	S=150 L2	S=200 L2	S=50 R1	S=80 R1	S=100 R1
16	115.4	161.4	181.4	269.9	294.9	–	8.7	8.7	8.7
20	125.5	170.5	190.5	275	315	390	12.4	12.4	12.4
25	134.5	180.5	200.5	277.5	317.5	392.5	10.5	11.5	11.5

Kolben-Ø	S=125 R1	S=150 R1	S=200 R1
16	8.7	8.7	–
20	12.4	12.4	12.4
25	11.5	11.5	11.5

Abmessungen  
MSC-16

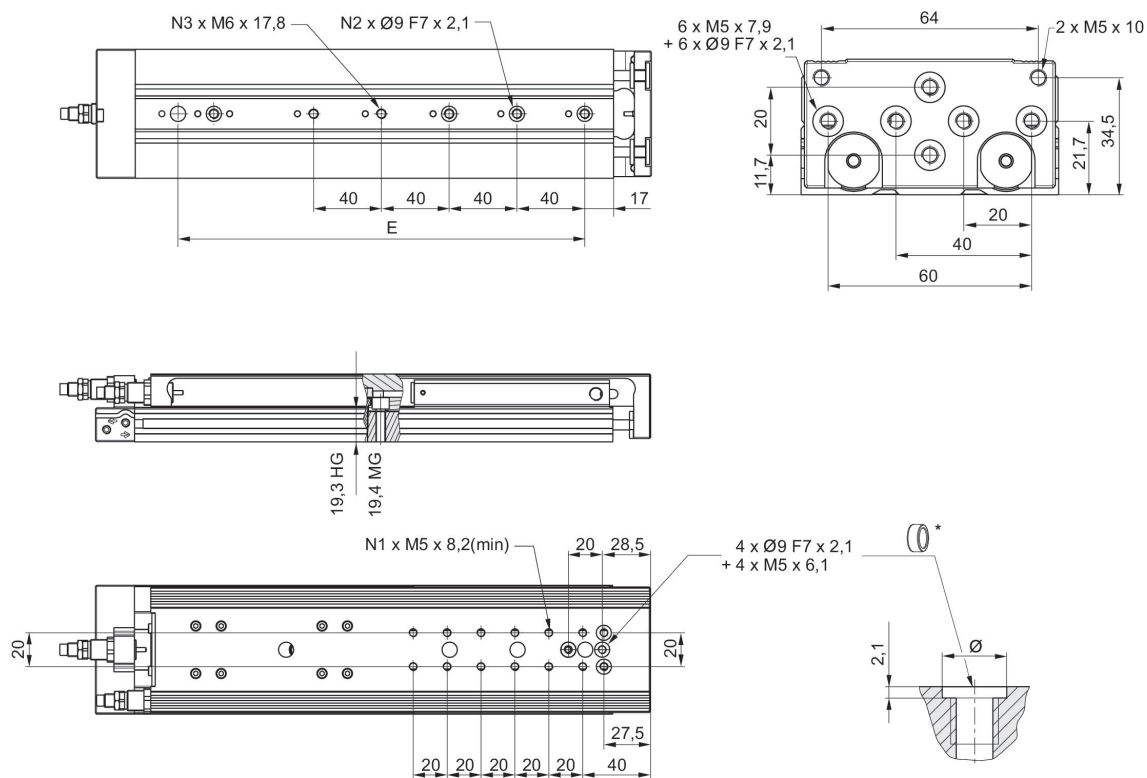

\* = Zentrierringe

Materialnummer	Kolben-Ø	Hub	E	N1	N2	N3
R412019175	16	125	200	12	4	5
R480643808	16	125	200	12	4	5
R412019188	16	125	200	12	4	5
R480640200	16	125	200	12	4	5
R412019176	16	150	240	12	4	5
R480643809	16	150	240	12	4	5
R412019189	16	150	240	12	4	5
R480640201	16	150	240	12	4	5

## Abmessungen MSC-20

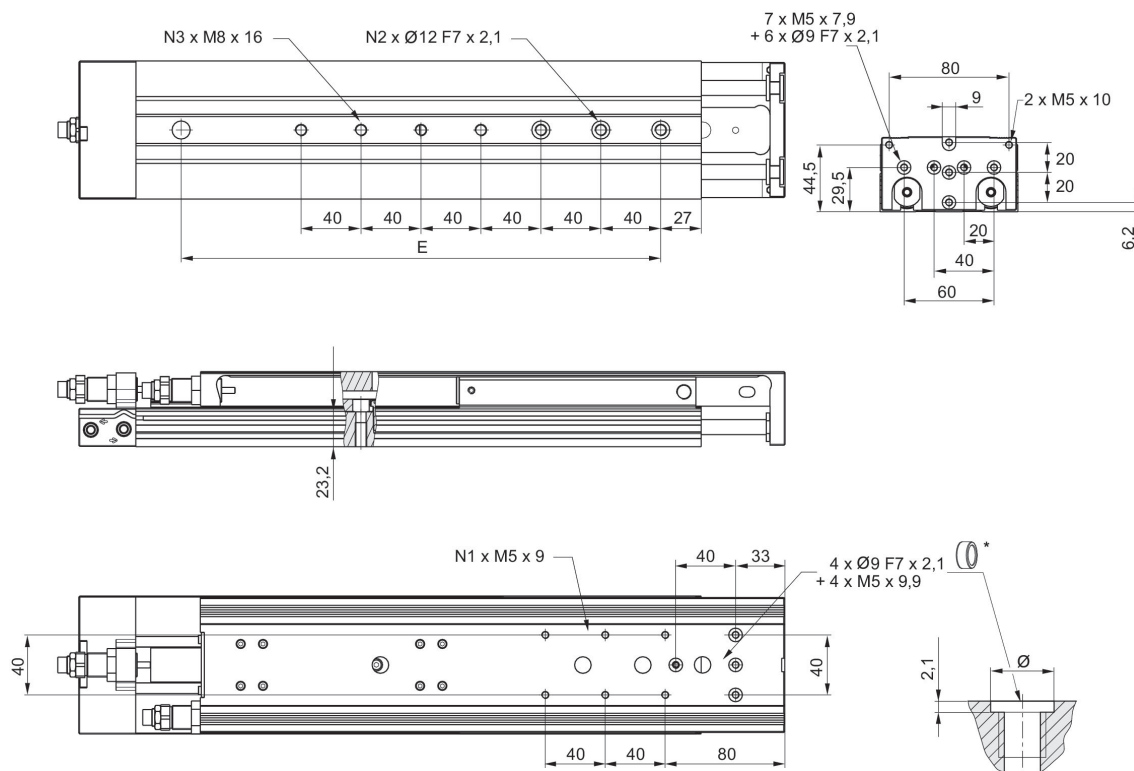

\* = Zentrierringe

Materialnummer	Kolben-Ø	Hub	E	N1	N2	N3
R412018917	20	125	200	6	4	5
R480643817	20	125	200	6	4	5
R412019005	20	125	200	6	4	5
R480640205	20	125	200	6	4	5
R412018918	20	150	240	6	4	5
R480643818	20	150	240	6	4	5
R412019006	20	150	240	6	4	5
R480640206	20	150	240	6	4	5
R412018919	20	200	320	6	4	7
R480643819	20	200	320	6	4	7
R412019007	20	200	320	6	4	7
R480640207	20	200	320	6	4	7

## Abmessungen MSC-25

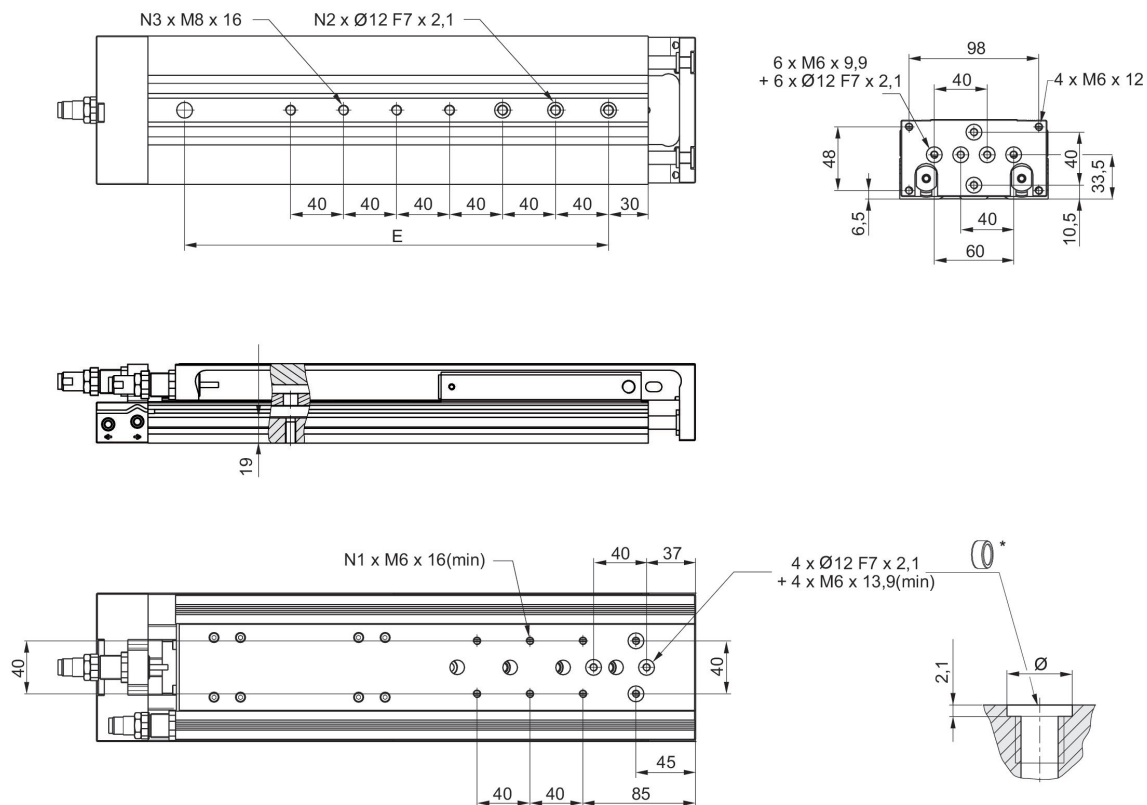

\* = Zentrierringe

Materialnummer	Kolben-Ø	Hub	E	N1	N2	N3
R412019030	25	125	200	4	4	5
R480643827	25	125	200	4	4	5
R412019041	25	125	200	4	4	5
R480640211	25	125	200	4	4	5
R412019031	25	150	240	6	4	5
R480643828	25	150	240	6	4	5
R412019042	25	150	240	6	4	5
R480640212	25	150	240	6	4	5
R412019032	25	200	320	6	4	7
R480643829	25	200	320	6	4	7
R412019043	25	200	320	6	4	7
R480640213	25	200	320	6	4	7

Tragfähigkeit

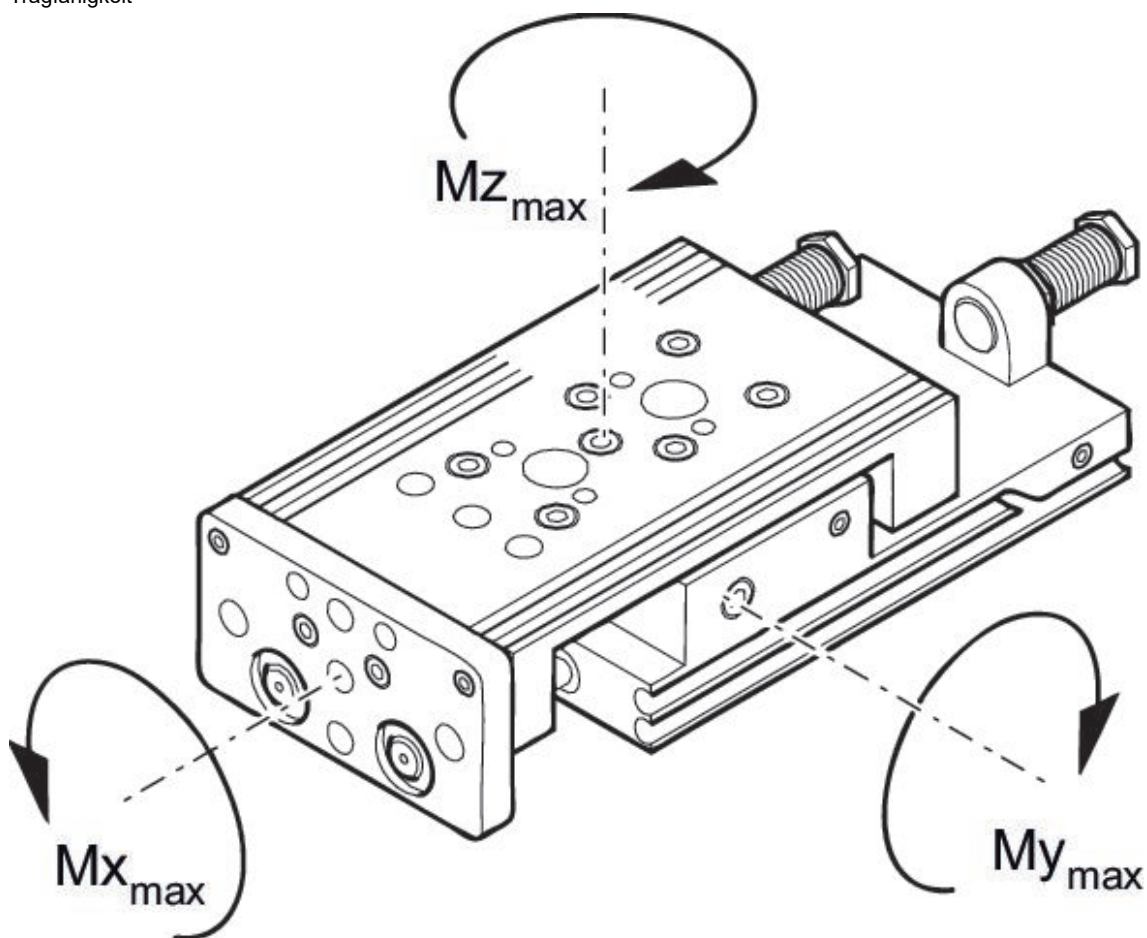

M = max. zulässiges Drehmoment

### Korrekturfaktor (a)

Kolben-Ø	S	a [mm]	d [mm]	$M_{x_{max}}$ [Nm]	$M_{y_{max}}$ [Nm]	$M_{z_{max}}$ [Nm]
16	50	85,5	15	38	29	29
20	50	90,5	20	93	65	65
25	50	96,5	24	100	90	90

S = Hub

### Gewicht beweglicher Teile [kg]

Kolben-Ø	S=10	S=20	S=30	S=40	S=50	S=80	S=100	S=125	S=150
16	0.375	0.375	0.375	0.4	0.45	0.615	0.65	0.725	0.765
20	0.655	0.655	0.655	0.69	0.765	0.985	1.035	1.2	1.29
25	1	1	1	1.1	1.225	1.45	1.625	1.885	2.085

Kolben-Ø	S=200
16	–
20	1.54
25	2.445

S = Hub

## Hubabhängige Maße

Kolben-Ø	S=10 EB	S=20 EB	S=30 EB	S=40 EB	S=50 EB	S=80 EB	S=100 EB	S=10 L1-R	S=20 L1-R
8	32	22	12	2	2	2	–	–	–
12	32	22	12	2	2	2	2	111	111
16	22	12	2	2	2	2	2	103.5	103.5
20	22	12	2	2	2	2	2	115	115
25	32	22	12	2	2	2	2	138.5	138.5

Kolben-Ø	S=30 L1-R	S=40 L1-R	S=50 L1-R	S=80 L1-R	S=100 L1-R	S=10 L1-S	S=20 L1-S	S=30 L1-S	S=40 L1-S
8	–	–	–	–	–	101.7	101.7	101.7	101.7
12	111	111	126	172	192	127.9	127.9	127.9	127.9
16	103.5	113.5	128.5	174.5	194.5	114.4	114.4	114.4	124.4
20	115	125	140	185	205	139.9	139.9	139.9	149.9
25	138.5	138.5	151.5	197.5	217.5	162.2	162.2	162.2	162.2

Kolben-Ø	S=50 L1-S	S=80 L1-S	S=100 L1-S	S=10 L2	S=20 L2	S=30 L2	S=40 L2	S=50 L2	S=80 L2
8	121.7	171.7	–	93.5	93.5	93.5	93.5	113.5	163.5
12	142.9	188.9	208.9	98.8	98.8	98.8	98.8	113.8	159.8
16	139.4	185.4	205.4	90.4	90.4	90.4	100.4	115.4	161.4
20	164.9	209.9	229.9	100.5	100.5	100.5	110.5	125.5	170.5
25	175.2	221.2	241.2	121.5	121.5	121.5	121.5	134.5	180.5

Kolben-Ø	S=100 L2	S=10 R1 max.	S=20 R1 max.	S=30 R1 max.	S=40 R1 max.	S=50 R1 max.	S=80 R1 max.	S=100 R1 max.	S=10 R2 max.
8	–	4.2	4.2	4.2	4.2	4.2	4.2	–	4.1
12	179.8	5.7	5.7	5.7	5.7	5.7	5.7	5.7	2
16	181.4	8.7	8.7	8.7	8.7	8.7	8.7	8.7	1.5
20	190.5	12.4	12.4	12.4	12.4	12.4	12.4	12.4	1.5
25	200.5	11.5	11.5	11.5	11.5	10.5	11.5	11.5	7.5

Kolben-Ø	S=20 R2 max.	S=30 R2 max.	S=40 R2 max.	S=50 R2 max.	S=80 R2 max.	S=100 R2 max.
8	4.1	4.1	4.1	4.1	4.1	–
12	2	2	2	10	12	12
16	1.5	1.5	1.5	6	7	5.7
20	1.5	1.5	11.5	9.5	14	14
25	7.5	7.5	7.5	3.3	7.5	9.2

Korrekturfaktor (a, d)

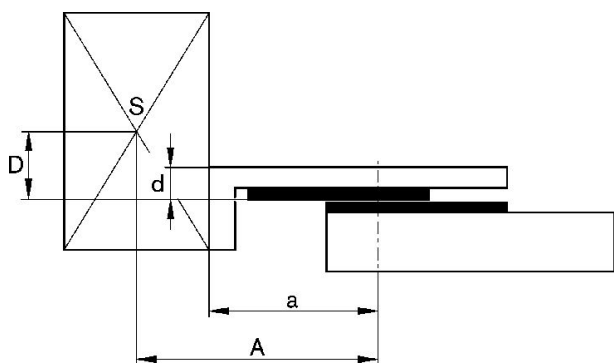

Korrekturfaktor (a, d)

horizontal

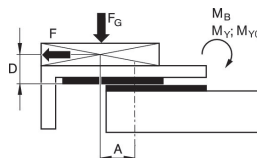

stat.	$M_{B0} = F_G \cdot A + F \cdot D$
dyn.	$M_B = F_G \cdot A$

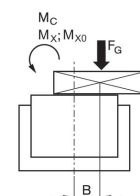

stat.	$M_{C0} = F_G \cdot B$
dyn.	$M_C = F_G \cdot B$

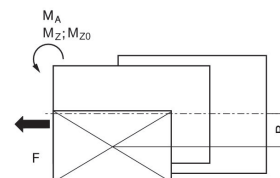

stat.	$M_{A0} = F \cdot B$
dyn.	$M_A = 0$

dyn.	$\frac{M_A}{M_1} + \frac{M_B}{M_2} + \frac{M_C}{M_3} \leq 1$
stat.	$\frac{M_{A0}}{M_{Z0}} + \frac{M_{B0}}{M_{Y0}} + \frac{M_{C0}}{M_{X0}} \leq 1$

$F = m \cdot a$   $FG = m \cdot g$   $a = 1250 \cdot V^2/H$   
 F = Verzögerungskraft [N]  $F_G$  = Gewichtskraft [N] m = Lastmasse [kg] a = Verzögerung [m/s<sup>2</sup>] g = Erdbeschleunigung 9,81 [m/s<sup>2</sup>] V = Geschwindigkeit H = Stoßdämpfers Hublänge [mm]

Korrekturfaktor (a, d)

vertikal

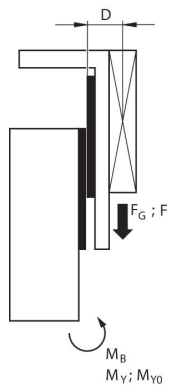

stat.	$M_{B0} = (F_G + F) \cdot D$
dyn.	$M_B = F_G \cdot D$

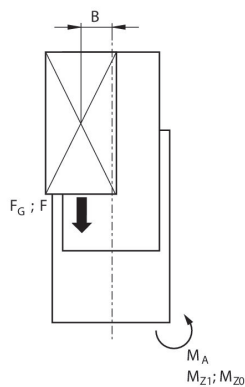

stat.	$M_{A0} = (F_G + F) \cdot B$
dyn.	$M_A = F_G \cdot B$

dyn.	$\frac{M_A}{M_1} + \frac{M_B}{M_2} \leq 1$
stat.	$\frac{M_{A0}}{M_{Z0}} + \frac{M_{B0}}{M_{Y0}} \leq 1$

$F = m \cdot a$   $F_G = m \cdot g$   $a = 1250 \cdot V^2 / H$   
 $F$  = Verzögerungskraft [N]  $F_G$  = Gewichtskraft [N]  $m$  = Lastmasse [kg]  $a$  = Verzögerung [m/s<sup>2</sup>]  $g$  = Erdbeschleunigung 9,81 [m/s<sup>2</sup>]  $V$  = Geschwindigkeit  $H$  = Stoßdämpfers Hublänge [mm]

Maximal bewegte Masse

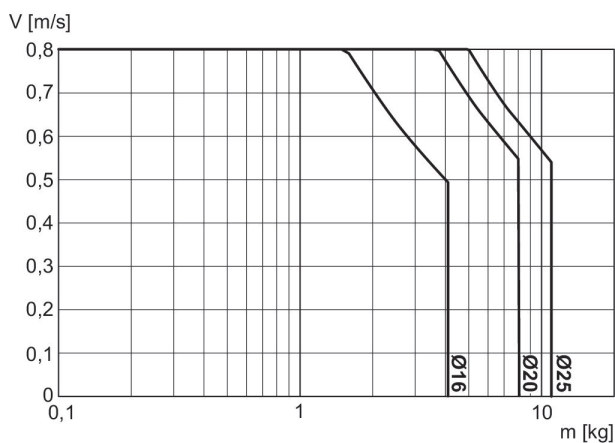

$V$  = Geschwindigkeit [m/s]  
 $m$  = Masse

**Korrekturfaktor erforderliche Geschwindigkeit ein- und ausfahrend, horizontal**

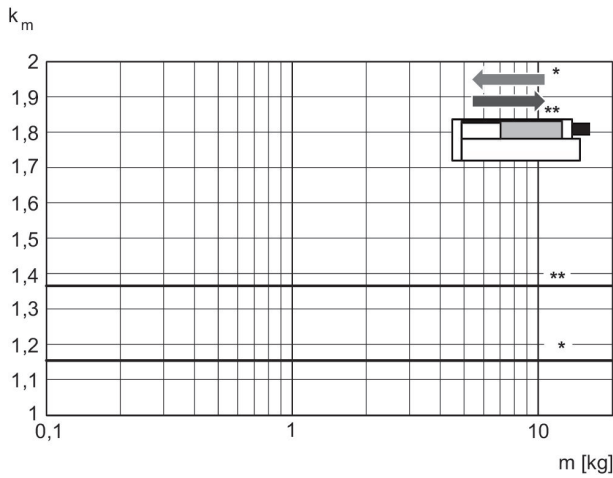

\* einfahrend  
\*\* ausfahrend  
 $V = s/1000 \cdot t \cdot km$   
V = Geschwindigkeit [m/s]  
S = Hub

**Korrekturfaktor erforderliche Geschwindigkeit ausfahrend, vertikal, nach oben**

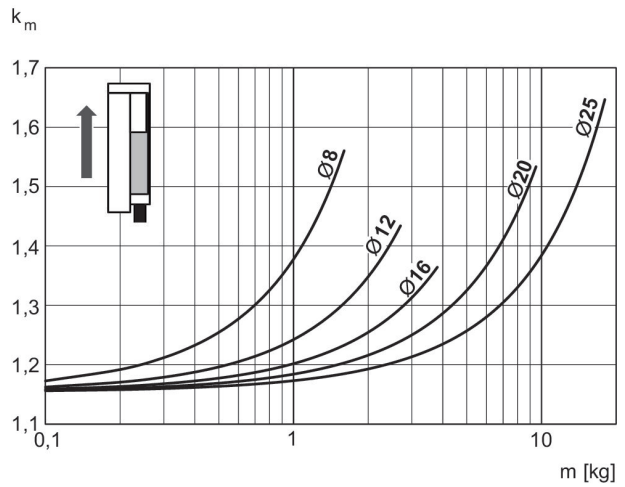

$V = s/1000 \cdot t \cdot km$   
V = Geschwindigkeit [m/s]  
S = Hub [mm]  
t = Zeit [s] für einen Hub  
m = Masse

**Korrekturfaktor erforderliche Geschwindigkeit einfahrend, vertikal, nach oben**

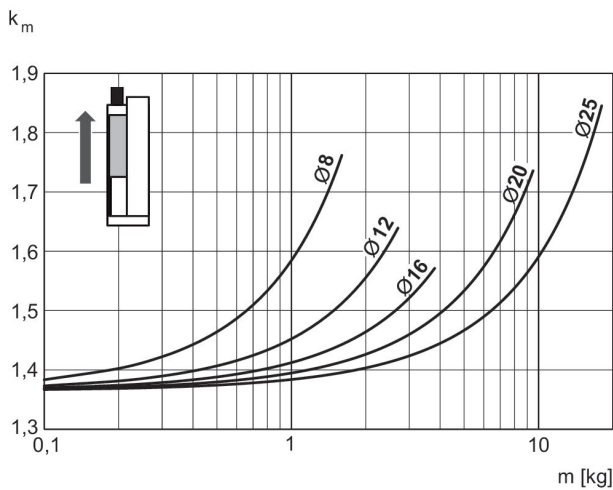

$V = s/1000 \cdot t \cdot km$   
V = Geschwindigkeit [m/s]  
S = Hub [mm]  
t = Zeit [s] für einen Hub  
m = Masse

**Korrekturfaktor erforderliche Geschwindigkeit einfahrend, vertikal, nach unten**

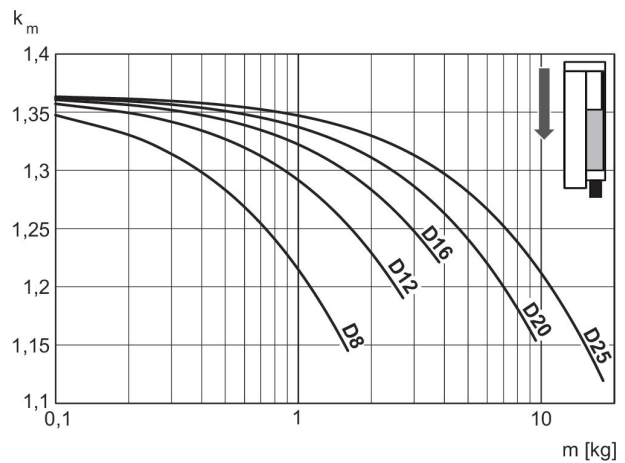

$V = s/1000 \cdot t \cdot km$   
V = Geschwindigkeit [m/s]  
S = Hub [mm]  
t = Zeit [s] für einen Hub  
m = Masse

**Korrekturfaktor erforderliche Geschwindigkeit ausfahrend, vertikal, nach unten**

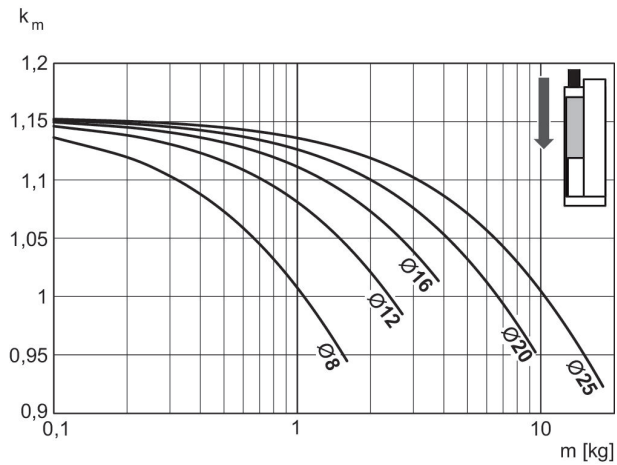

$V = s/1000 \cdot t \cdot km$   
 $V$  = Geschwindigkeit [m/s]  
 $S$  = Hub [mm]  
 $t$  = Zeit [s] für einen Hub  
 $m$  = Masse

**Faktor erreichbare Geschwindigkeit**

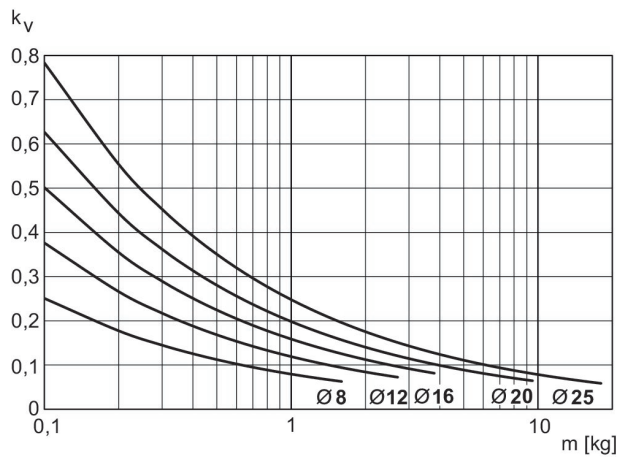

$V = \sqrt{s} \cdot kv$   
 $V$  = Geschwindigkeit [m/s]  
 $S$  = Hub [mm]  
 $m$  = Masse

## Minischlitten, Serie MSC-MG-EE

Wirkprinzip: doppeltwirkend

Dämpfung: elastisch

Easy2Combine: fähig

: mit Magnetkolben

: mit Doppelkolben

: mit integrierter Kugelschienenführung

Umgebungstemperatur min./max.: 0 °C ... 60 °C

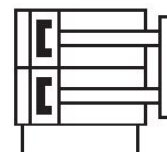

Kolben-Ø	8 mm	12 mm	16 mm	20 mm	25 mm
Anschlüsse	M5	M5	M5	G 1/8	G 1/8
Hub 10	R480640120	R480640126	R480640133	R480640140	R480640147
20	R480640121	R480640127	R480640134	R480640141	R480640148
30	R480640122	R480640128	R480640135	R480640142	R480640149
40	R480640123	R480640129	R480640136	R480640143	R480640150
50	R480640124	R480640130	R480640137	R480640144	R480640151
80	R480640125	R480640131	R480640138	R480640145	R480640152
100	-	R480640132	R480640139	R480640146	R480640153

Kolben-Ø	8 mm	12 mm	16 mm	20 mm	25 mm
Kolbenkraft einfahrend, theoretisch	48 N	107 N	218 N	297 N	520 N
Kolbenkraft ausfahrend, theoretisch	63 N	143 N	253 N	396 N	619 N
Dämpfungsenergie	0.06 J	0.06 J	0.3 J	0.4 J	0.5 J
Dämpfungslänge	0.3 mm	0.75 mm	1 mm	1.2 mm	1.6 mm
Geschwindigkeit max.	0.8 m/s	0.8 m/s	0.8 m/s	0.8 m/s	0.8 m/s
Betriebsdruck min./max.	1.5 bar ... 10 bar	1 bar ... 10 bar	1 bar ... 10 bar	1 bar ... 10 bar	1 bar ... 10 bar

Abmessungen

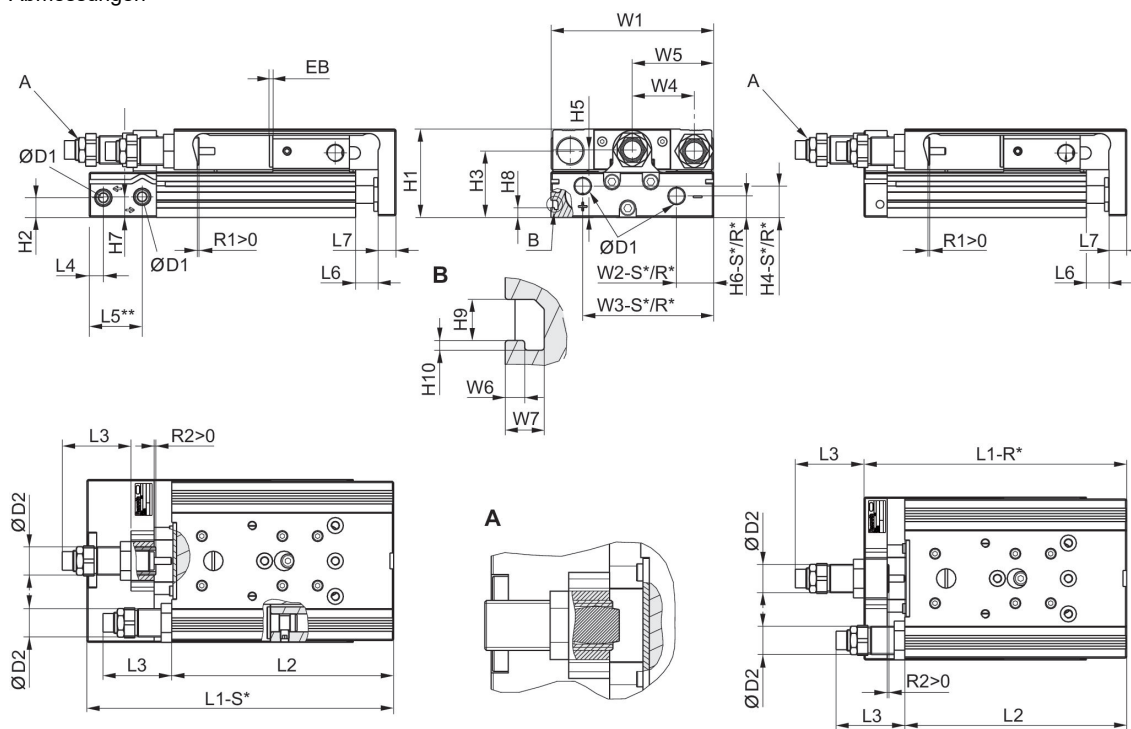

R\*: Bodenausführung mit Luftanschlüssen nur hinten  
 S\*: Bodenausführung mit Luftanschlüssen hinten und seitlich  
 \*\* Ø 8 hat eine andere Bezugsfläche.

Hubabhängige Maße

Kolben-Ø	S=10 EB	S=20 EB	S=30 EB	S=40 EB	S=50 EB	S=80 EB	S=100 EB	S=10 L1-R	S=20 L1-R
8	32	22	12	2	2	2	-	-	-
Kolben-Ø	S=30 L1-R	S=40 L1-R	S=50 L1-R	S=80 L1-R	S=100 L1-R	S=10 L1-S	S=20 L1-S	S=30 L1-S	S=40 L1-S
8	-	-	-	-	-	101.7	101.7	101.7	101.7
Kolben-Ø	S=50 L1-S	S=80 L1-S	S=100 L1-S	S=10 L2	S=20 L2	S=30 L2	S=40 L2	S=50 L2	S=80 L2
8	121.7	171.7	-	93.5	93.5	93.5	93.5	113.5	163.5
Kolben-Ø	S=100 L2	S=10 R1 max.	S=20 R1 max.	S=30 R1 max.	S=40 R1 max.	S=50 R1 max.	S=80 R1 max.	S=100 R1 max.	S=10 R2 max.
8	-	9.2	9.2	9.2	9.2	9.2	9.2	-	4.5
Kolben-Ø	S=20 R2 max.	S=30 R2 max.	S=40 R2 max.	S=50 R2 max.	S=80 R2 max.	S=100 R2 max.			
8	4.5	4.5	4.5	4.5	4.5	-			

Kolben-Ø	Ø D1	Ø D2	H1	H2	H3	H4-R	H4-S	H5	H6-R
8	M5	M10x1	28	9.6	20.5	-	7.5	19.5	-
12	M5	M12x1	34	5.7	25	11.2	11.2	24.5	5.7
16	M5	M12x1	40	7.2	29	12.2	12.2	31	7.7
20	G 1/8	M16x1,5	50	11.2	37.5	17.3	17.3	38.2	11.7
25	G 1/8	M18x1,5	60	14.2	44	15.5	22.9	46.5	13.2

Kolben-Ø	H6-S	H7	H8	H9	H10	L3 max.	L4	L5 2)	L6
8	5.5	18	-	-	-	16	9.8	-	1.9
12	5.7	8.3	-	-	-	20.2	7.2	22.5	2
16	7.7	11.2	-	-	-	18.4	6.5	17.7	2
20	12.2	11.7	5.5	4.2	1	27.9	8	30	2.1
25	21.7	16.2	6.9	5.2	1.5	29.2	9	31	2.1

Kolben-Ø	L7	W1	W2-R	W2-S	W3-R	W3-S	W4	W5	W6
8	6	50.2	-	19.3	-	30.5	18	W1/2	-
12	8	66	28.8	28.8	53	53	24.5	W1/2	-
16	10	76	31	31	60.5	60.5	30	W1/2	-
20	10	92	10	21	74	74	35	W1/2	2
25	12	112	11	14	92	92	44	W1/2	2.5

Kolben-Ø	W7
8	-
12	-
16	-
20	4
25	4.8

## MSC-08

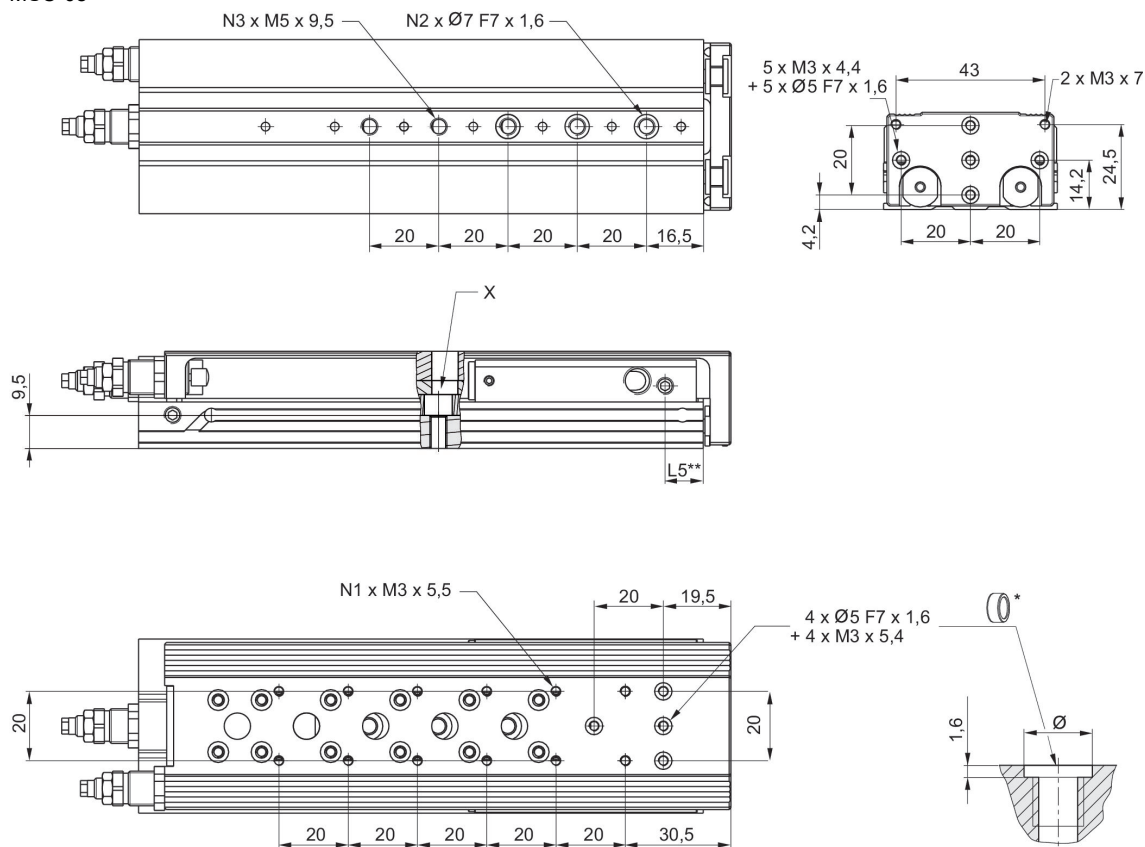

\* = Zentrierringe

\*\* Ø 8 hat eine andere Bezugsfläche.

Materialnummer	Kolben-Ø	S	N1	N2	N3	L5	X
R480640120	8	10	4	2	2	11	
R480640121	8	20	4	2	2	11	
R480640122	8	30	4	2	2	11	
R480640123	8	40	4	2	2	11	
R480640124	8	50	4	3	3	11	1)
R480640125	8	80	8	3	5	11	

S = Hub

1) Zugang zur Durchgangsbohrung erst nach Demontage der Hubbegrenzungsbolzen

## Abmessungen MSC-12

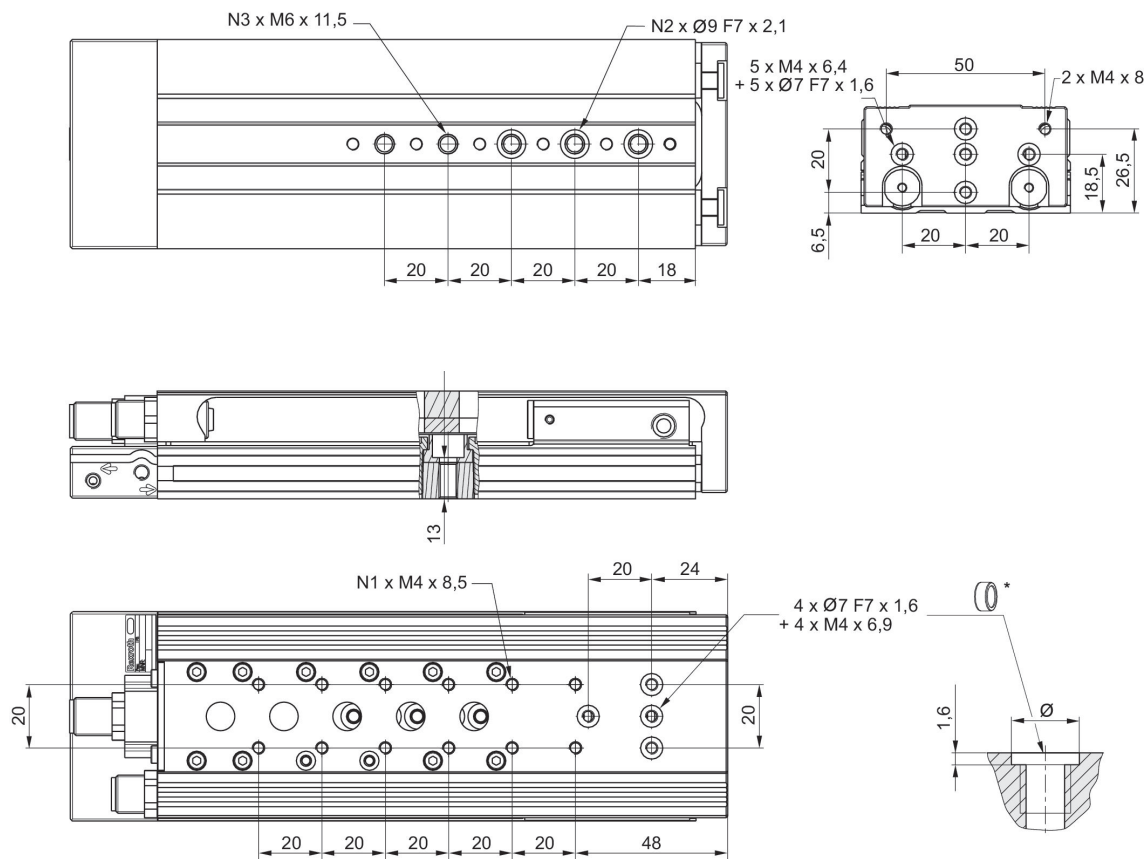

\* = Zentrierringe

Materialnummer	Kolben-Ø	S	N1	N2	N3
R480640126	12	10	2	2	2
R480640127	12	20	2	2	2
R480640128	12	30	2	2	2
R480640129	12	40	2	2	2
R480640130	12	50	4	3	3
R480640131	12	80	6	3	5
R480640132	12	100	8	3	5

S = Hub

## MSC-16

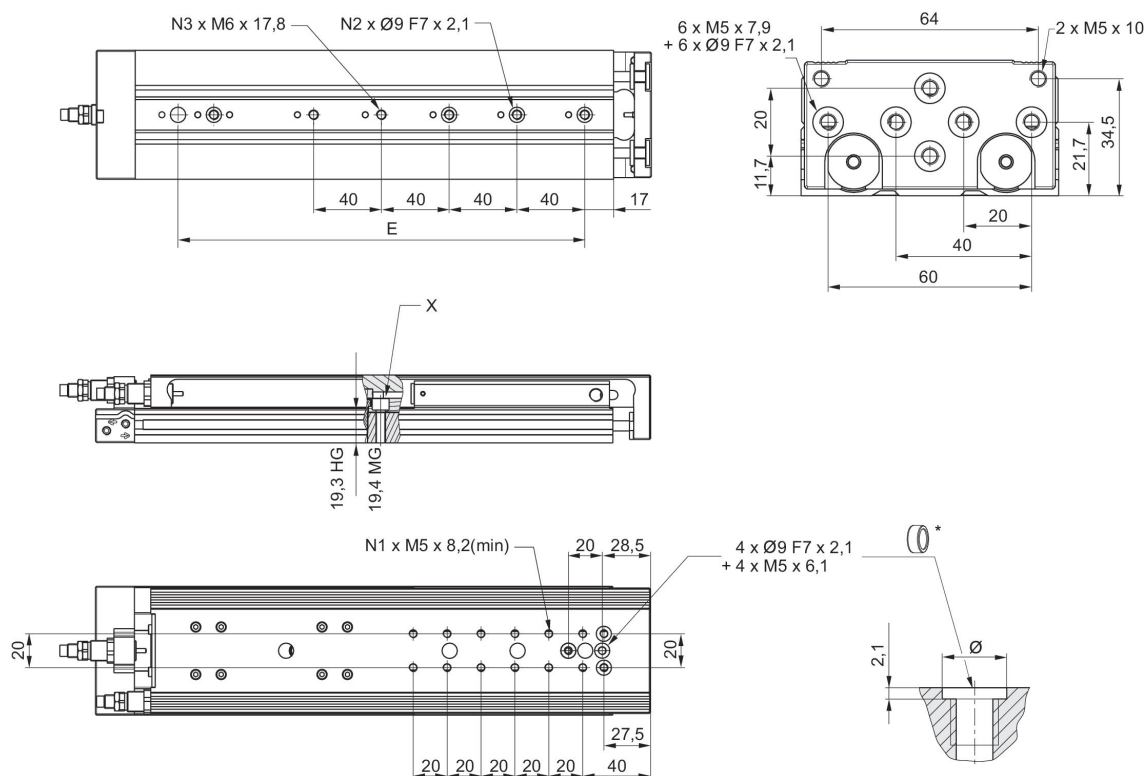

\* = Zentrierringe

Materialnummer	Kolben-Ø	S	N1	N2	N3	X
R480640133	16	10	2	2	2	1)
R480640134	16	20	2	2	2	1)
R480640135	16	30	2	2	2	
R480640136	16	40	4	2	2	
R480640137	16	50	4	2	2	
R480640138	16	80	6	3	3	
R480640139	16	100	8	3	3	

S = Hub

1) Zugang zur Durchgangsbohrung erst nach Demontage der Hubbegrenzungsbolzen

## MSC-20

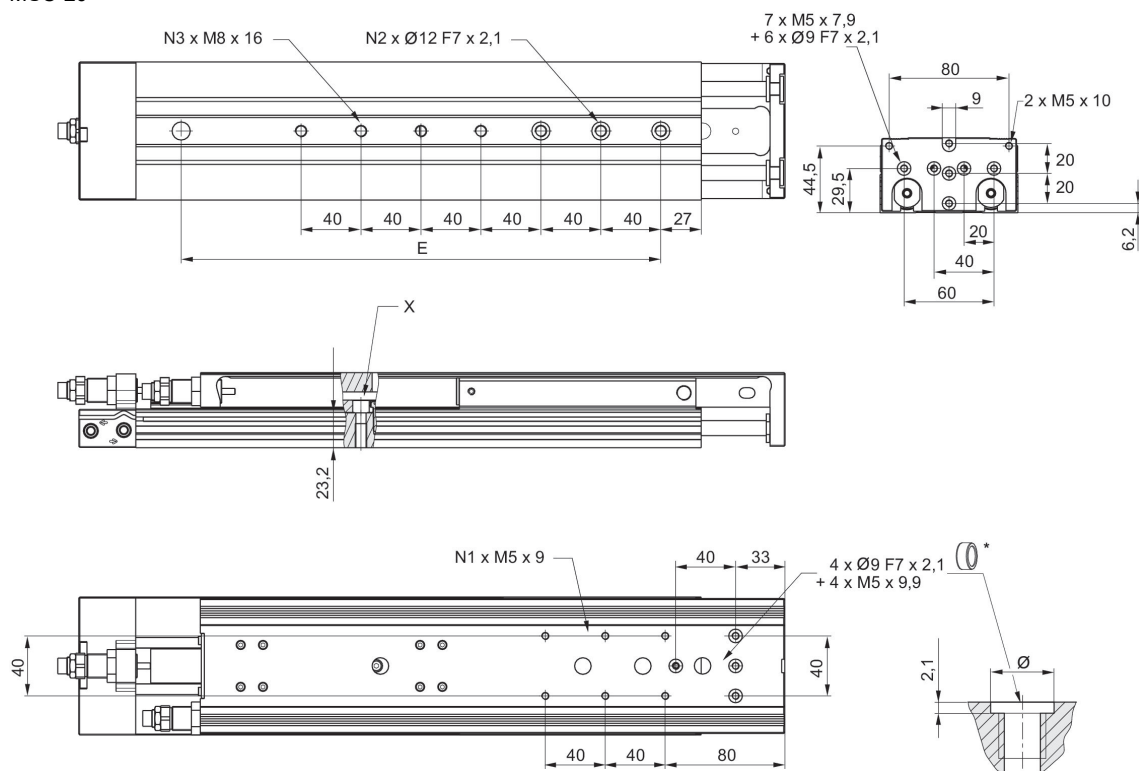

\* = Zentrierringe

Materialnummer	Kolben-Ø	S	N1	N2	N3	X
R480640140	20	10	2	2	2	1)
R480640141	20	20	2	2	2	1)
R480640142	20	30	2	2	2	
R480640143	20	40	2	2	2	
R480640144	20	50	2	2	2	
R480640145	20	80	4	3	3	
R480640146	20	100	4	3	3	

S = Hub

1) Zugang zur Durchgangsbohrung erst nach Demontage der Hubbegrenzungsbolzen

MSC-25

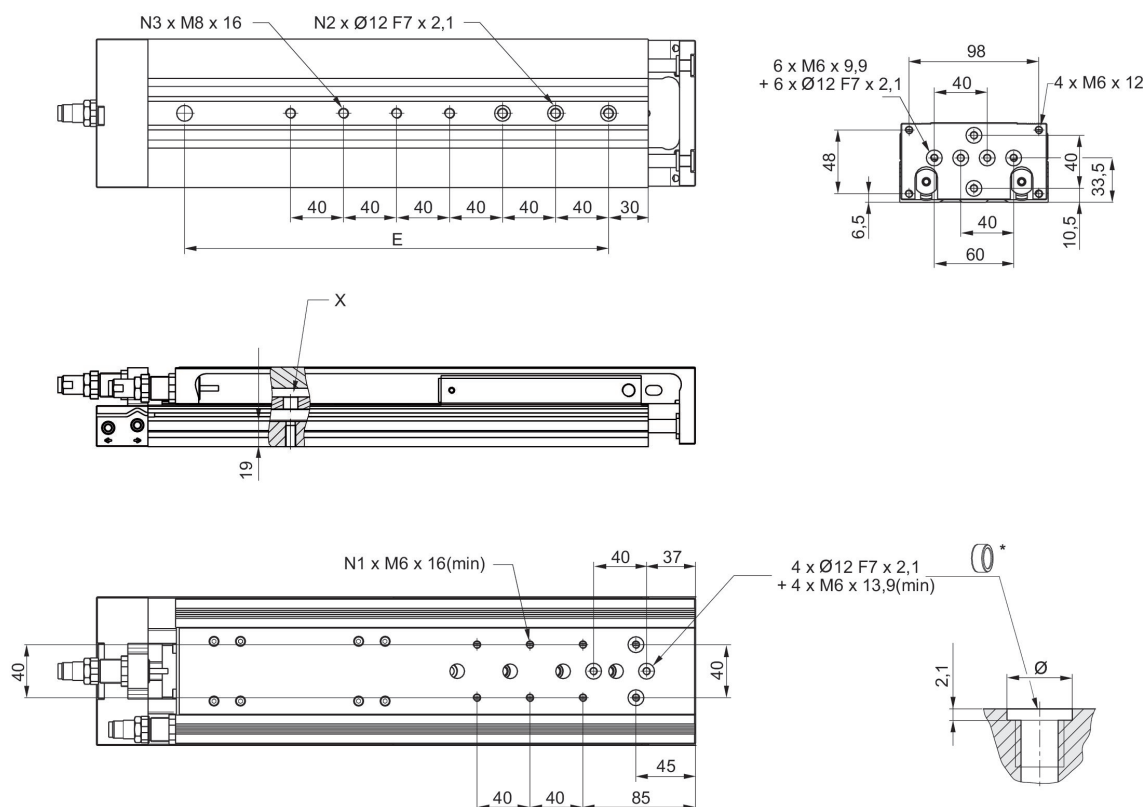

\* = Zentrierringe

Materialnummer	Kolben-Ø	S	N1	N2	N3	X
R480640147	25	10	2	2	2	1)
R480640148	25	20	2	2	2	1)
R480640149	25	30	2	2	2	1)
R480640150	25	40	2	2	2	
R480640151	25	50	4	2	2	
R480640152	25	80	4	3	3	
R480640153	25	100	4	3	3	

S = Hub

1) Zugang zur Durchgangsbohrung erst nach Demontage der Hubbegrenzungsbolzen

Tragfähigkeit

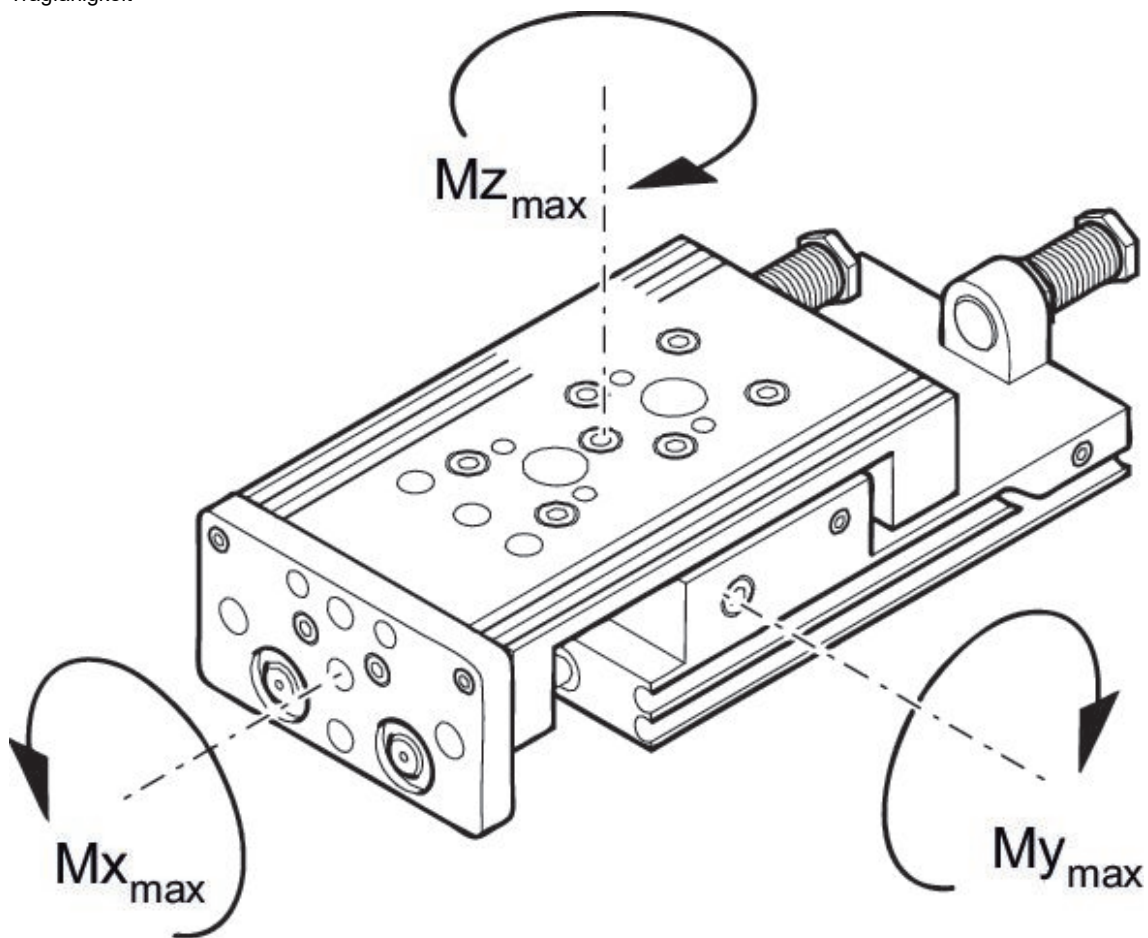

M = max. zulässiges Drehmoment

Korrekturfaktor (a)

Materialnummer	Kolben-Ø	Hub	a [mm]	d [mm]	$M_{x_{max}}$ [Nm]	$M_{y_{max}}$ [Nm]	$M_{z_{max}}$ [Nm]
R480640120	8	10	69.5	12	5.8	5.9	5.9
R480640121	8	20	69.5	12	5.8	5.9	5.9
R480640122	8	30	69.5	12	5.8	5.9	5.9
R480640123	8	40	69.5	12	5.8	5.9	5.9
R480640124	8	50	83	12	5.8	5.9	5.9
R480640125	8	80	121	12	8	14.6	14.6
R480640126	12	10	77	15	13.8	6.45	6.45
R480640127	12	20	77	15	13.8	6.45	6.45
R480640128	12	30	77	15	13.8	6.45	6.45
R480640129	12	40	77	15	13.8	6.45	6.45
R480640130	12	50	81	15	13.8	6.45	6.45
R480640131	12	80	117	15	17.3	15.6	15.6
R480640132	12	100	137	15	17.3	15.6	15.6
R480640133	16	10	65	15	31.6	11.95	11.95
R480640134	16	20	65	15	31.6	11.95	11.95
R480640135	16	30	65	15	31.6	11.95	11.95
R480640136	16	40	75	15	31.6	11.95	11.95
R480640137	16	50	86	15	31.6	11.95	11.95
R480640138	16	80	123	15	45	27.3	27.3
R480640139	16	100	144	15	45	27.3	27.3
R480640140	20	10	75	20	31.6	11.95	11.95
R480640141	20	20	75	20	31.6	11.95	11.95
R480640142	20	30	75	20	31.6	11.95	11.95
R480640143	20	40	75	20	31.6	11.95	11.95
R480640144	20	50	92	20	31.6	11.95	11.95
R480640145	20	80	125	20	45	27.3	27.3
R480640146	20	100	143	20	45	27.3	27.3
R480640147	25	10	85	24	87	24.5	24.5
R480640148	25	20	85	24	87	24.5	24.5
R480640149	25	30	85	24	87	24.5	24.5
R480640150	25	40	85	24	87	24.5	24.5
R480640151	25	50	102	24	87	24.5	24.5
R480640152	25	80	134	24	110	62.5	62.5
R480640153	25	100	152	24	110	62.5	62.5

Gewicht beweglicher Teile [kg]

Kolben-Ø	S=10	S=20	S=30	S=40	S=50	S=80	S=100	S=125	S=150
8	0.165	0.165	0.165	0.165	0.195	0.265	-	-	-
12	0.28	0.28	0.28	0.28	0.315	0.403	0.46	-	-
16	0.375	0.375	0.375	0.4	0.45	0.615	0.65	0.725	0.765
20	0.655	0.655	0.655	0.69	0.765	0.985	1.035	1.2	1.29
25	1.1	1.1	1.1	1.1	1.225	1.45	1.625	1.885	2.085

Kolben-Ø	S=200
8	-
12	-
16	-
20	1.54
25	2.445

S = Hub

Korrekturfaktor (a, d)

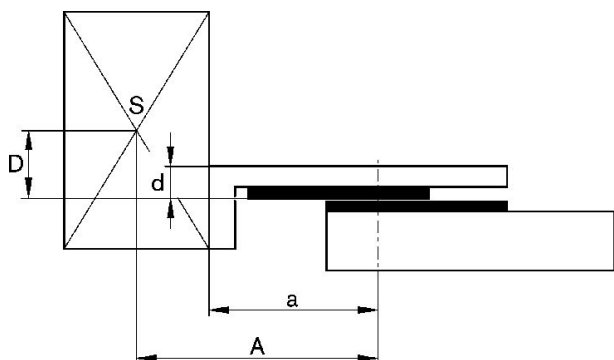

Korrekturfaktor (a, d)

horizontal

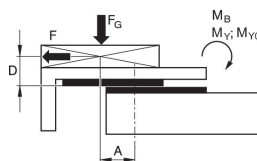

stat.	$M_{B0} = F_G \cdot A + F \cdot D$
dyn.	$M_B = F_G \cdot A$

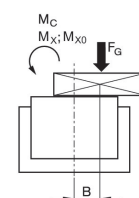

stat.	$M_{C0} = F_G \cdot B$
dyn.	$M_C = F_G \cdot B$

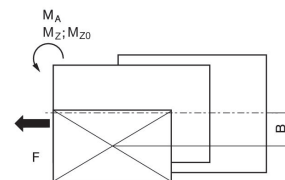

stat.	$M_{A0} = F \cdot B$
dyn.	$M_A = 0$

dyn.	$\frac{M_A}{M_1} + \frac{M_B}{M_2} + \frac{M_C}{M_3} \leq 1$
stat.	$\frac{M_{A0}}{M_{z0}} + \frac{M_{B0}}{M_{y0}} + \frac{M_{C0}}{M_{x0}} \leq 1$

$F = m \cdot a$   $F_G = m \cdot g$   $a = 1250 \cdot V^2 / H$   
 F = Verzögerungskraft [N]  $F_G$  = Gewichtskraft [N] m = Lastmasse [kg] a = Verzögerung [m/s<sup>2</sup>] g = Erdbeschleunigung 9,81 [m/s<sup>2</sup>] V = Geschwindigkeit H = Stoßdämpfers Hublänge [mm]

Korrekturfaktor (a, d)

vertikal

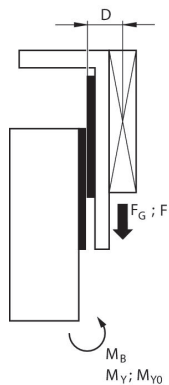

stat.	$M_{B0} = (F_G + F) \cdot D$
dyn.	$M_B = F_G \cdot D$

Maximal bewegte Masse

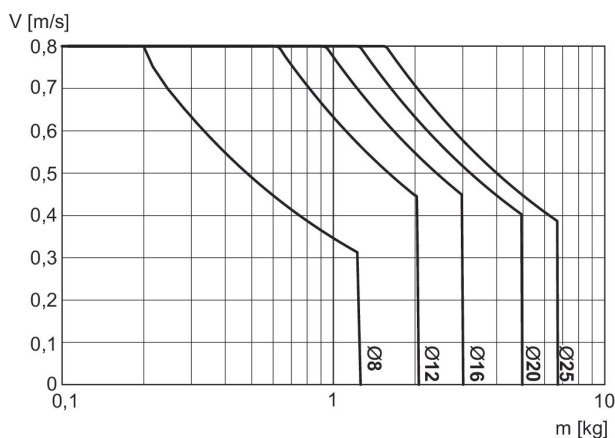

V = Geschwindigkeit [m/s]  
m = Masse

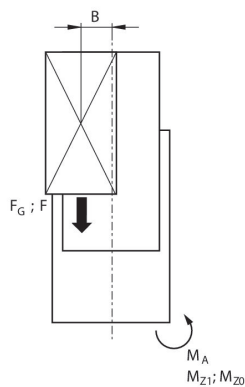

stat.	$M_{A0} = (F_G + F) \cdot B$
dyn.	$M_A = F_G \cdot B$

dyn.	$\frac{M_A}{M_1} + \frac{M_B}{M_2} \leq 1$
stat.	$\frac{M_{A0}}{M_{Z0}} + \frac{M_{B0}}{M_{Y0}} \leq 1$

$F = m \cdot a$   $F_G = m \cdot g$   $a = 1250 \cdot V^2 / H$   
 F = Verzögerungskraft [N]  $F_G$  = Gewichtskraft [N] m = Lastmasse [kg] a = Verzögerung [m/s<sup>2</sup>]  
 g = Erdbeschleunigung 9,81 [m/s<sup>2</sup>] V = Geschwindigkeit H = Stoßdämpfers Hublänge [mm]

**Korrekturfaktor erforderliche Geschwindigkeit ein- und ausfahrend, horizontal**

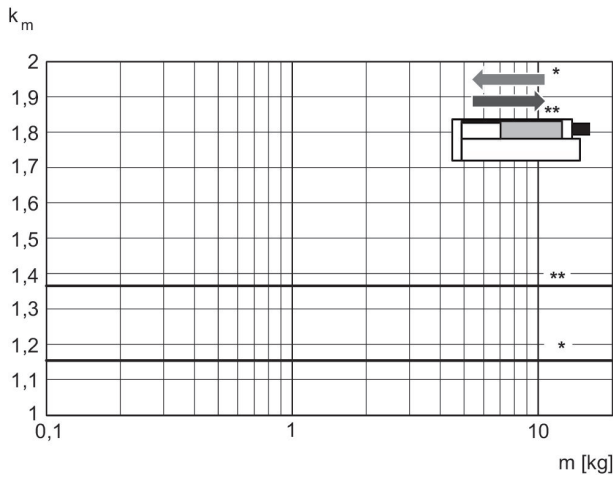

\* einfahrend  
\*\* ausfahrend  
 $V = s/1000 \cdot t \cdot km$   
V = Geschwindigkeit [m/s]  
S = Hub

**Korrekturfaktor erforderliche Geschwindigkeit ausfahrend, vertikal, nach oben**

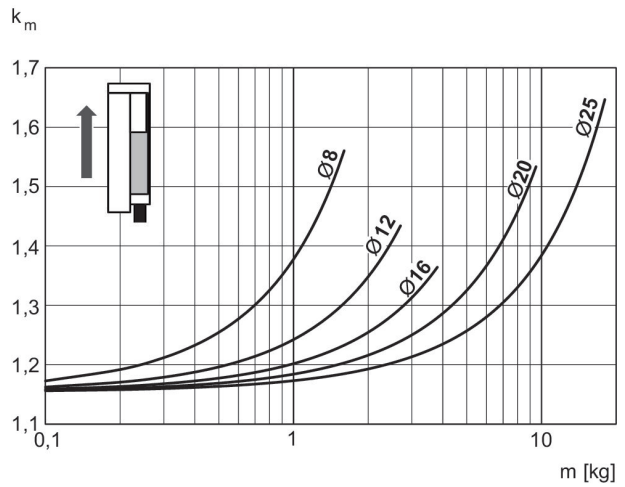

$V = s/1000 \cdot t \cdot km$   
V = Geschwindigkeit [m/s]  
S = Hub [mm]  
t = Zeit [s] für einen Hub  
m = Masse

**Korrekturfaktor erforderliche Geschwindigkeit einfahrend, vertikal, nach oben**

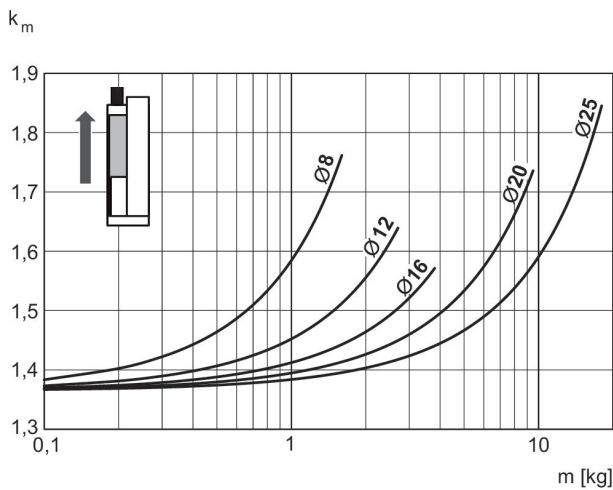

$V = s/1000 \cdot t \cdot km$   
V = Geschwindigkeit [m/s]  
S = Hub [mm]  
t = Zeit [s] für einen Hub  
m = Masse

**Korrekturfaktor erforderliche Geschwindigkeit einfahrend, vertikal, nach unten**

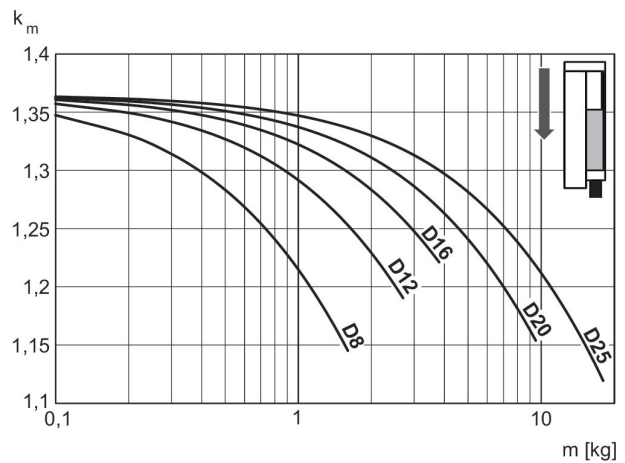

$V = s/1000 \cdot t \cdot km$   
V = Geschwindigkeit [m/s]  
S = Hub [mm]  
t = Zeit [s] für einen Hub  
m = Masse

**Korrekturfaktor erforderliche Geschwindigkeit ausfahrend, vertikal, nach unten**

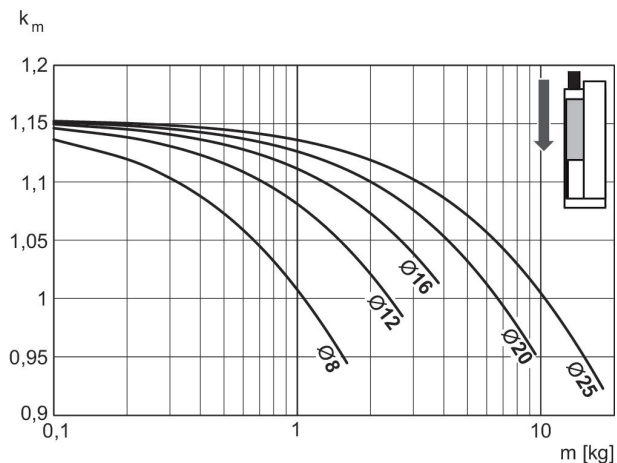

$V = s/1000 \cdot t \cdot km$   
 $V$  = Geschwindigkeit [m/s]  
 $S$  = Hub [mm]  
 $t$  = Zeit [s] für einen Hub  
 $m$  = Masse

**Faktor erreichbare Geschwindigkeit**

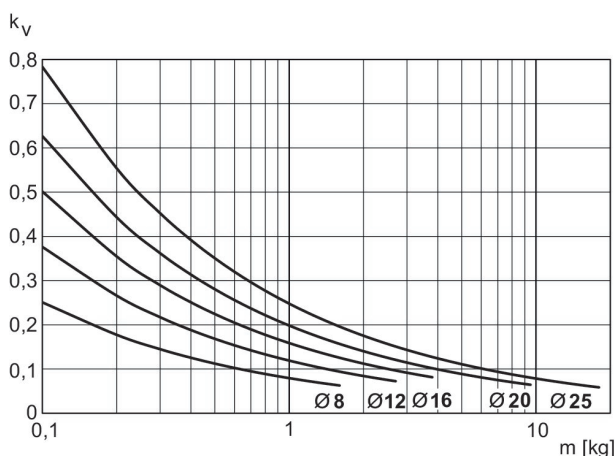

$V = \sqrt{s} \cdot kv$   
 $V$  = Geschwindigkeit [m/s]  
 $S$  = Hub [mm]  
 $m$  = Masse

### Minischlitten, Serie MSC-MG-EM

Wirkprinzip: doppeltwirkend  
 Dämpfung: elastisch mit Metall-Endanschlag  
 Easy2Combine: fähig  
 : mit Magnetkolben  
 : mit Doppelkolben  
 : mit integrierter Kugelschienenführung  
 Umgebungstemperatur min./max.: 0 °C ... 60 °C

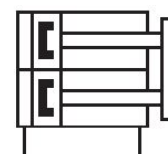

Kolben-Ø	8 mm	12 mm	16 mm	20 mm	25 mm
Anschlüsse	M5	M5	M5	G 1/8	G 1/8
Hub 10	R480643754	R480643760	R480643767	R480643774	R480643781
20	R480643755	R480643761	R480643768	R480643775	R480643782
30	R480643756	R480643762	R480643769	R480643776	R480643783
40	R480643757	R480643763	R480643770	R480643777	R480643784
50	R480643758	R480643764	R480643771	R480643778	R480643785
80	R480643759	R480643765	R480643772	R480643779	R480643786
100	-	R480643766	R480643773	R480643780	R480643787

Kolben-Ø	8 mm	12 mm	16 mm	20 mm	25 mm
Kolbenkraft einfahrend, theoretisch	48 N	107 N	218 N	297 N	520 N
Kolbenkraft ausfahrend, theoretisch	63 N	143 N	253 N	396 N	619 N
Dämpfungsenergie	0.03 J	0.06 J	0.12 J	0.3 J	0.4 J
Dämpfungslänge	0.65 mm	1.9 mm	1.9 mm	3.05 mm	2.5 mm
Geschwindigkeit max.	0.8 m/s	0.8 m/s	0.8 m/s	0.8 m/s	0.8 m/s
Betriebsdruck min./max.	3 bar ... 10 bar	3 bar ... 10 bar	3 bar ... 10 bar	3 bar ... 10 bar	3 bar ... 10 bar

Abmessungen

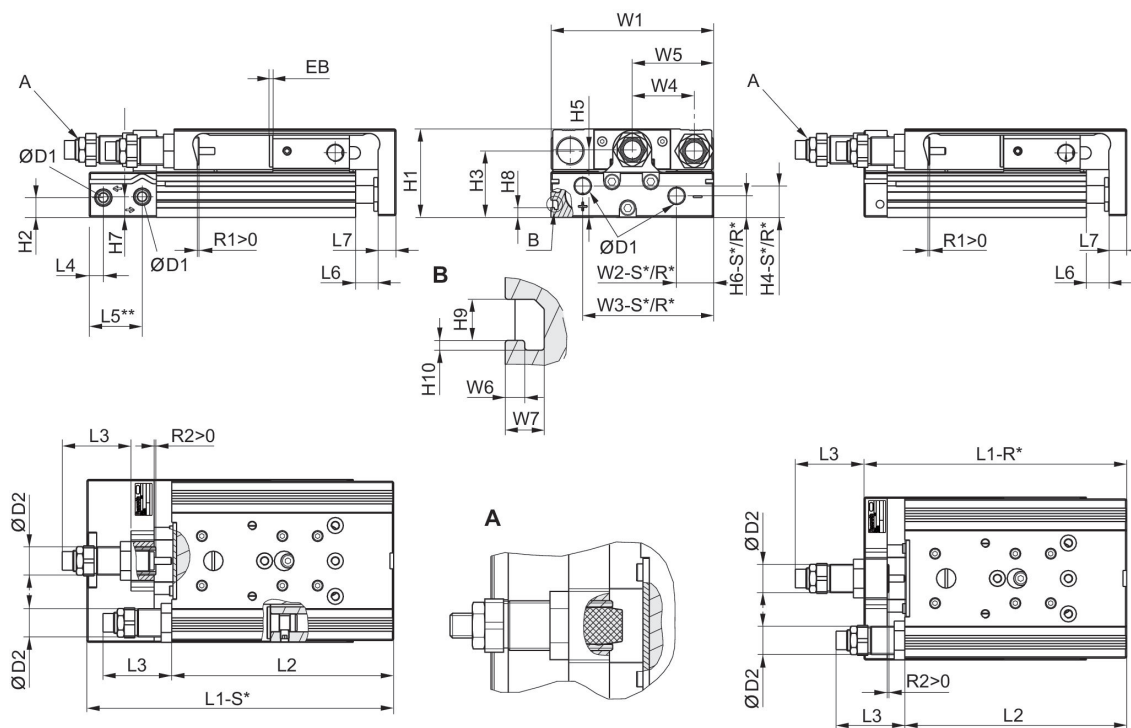

R\*: Bodenausführung mit Luftanschlüssen nur hinten  
S\*: Bodenausführung mit Luftanschlüssen hinten und seitlich  
\*\* Ø 8 hat eine andere Bezugsfläche.

Abmessungen

Kolben-Ø	Ø D1	Ø D2	H1	H2	H3	H4-R	H4-S	H5	H6-R
8	M5	M10x1	28	9.6	20.5	-	7.5	19.5	-
12	M5	M12x1	34	5.7	25	11.2	11.2	24.5	5.7
16	M5	M12x1	40	7.2	29	12.2	12.2	31	7.7
20	G 1/8	M16x1,5	50	11.2	37.5	17.3	17.3	38.2	11.7
25	G 1/8	M18x1,5	60	14.2	44	15.5	22.9	46.5	13.2

Kolben-Ø	H6-S	H7	H8	H9	H10	L3 max.	L4	L5 2)	L6
8	5.5	18	-	-	-	27.8	9.8	-	1.9
12	5.7	8.3	-	-	-	31.8	7.2	22.5	2
16	7.7	11.2	-	-	-	30	6.5	17.7	2
20	12.2	11.7	5.5	4.2	1	43.7	8	30	2.1
25	21.7	16.2	6.9	5.2	1.5	41.9	9	31	2.1

Kolben-Ø	L7	W1	W2-R	W2-S	W3-R	W3-S	W4	W5	W6
8	6	50.2	–	19.3	–	30.5	18	W1/2	–
12	8	66	28.8	28.8	53	53	24.5	W1/2	–
16	10	76	31	31	60.5	60.5	30	W1/2	–
20	10	92	10	21	74	74	35	W1/2	2
25	12	112	11	14	92	92	44	W1/2	2.5

Kolben-Ø	W7
8	–
12	–
16	–
20	4
25	4.8

### Gewicht beweglicher Teile [kg]

Kolben-Ø	S=10	S=20	S=30	S=40	S=50	S=80	S=100	S=125	S=150
8	0.165	0.165	0.165	0.165	0.195	0.265	–	–	–
12	0.28	0.28	0.28	0.28	0.315	0.403	0.46	–	–
16	0.375	0.375	0.375	0.4	0.45	0.615	0.65	0.725	0.765
20	0.655	0.655	0.655	0.69	0.765	0.985	1.035	1.2	1.29
25	1.1	1.1	1.1	1.1	1.225	1.45	1.625	1.885	2.085

Kolben-Ø	S=200
8	–
12	–
16	–
20	1.54
25	2.445

### Hubabhängige Maße

Kolben-Ø	S=10 EB	S=20 EB	S=30 EB	S=40 EB	S=50 EB	S=80 EB	S=100 EB	S=10 L1-R	S=20 L1-R
8	32	22	12	2	2	2	–	–	–
12	32	22	12	2	2	2	2	111	111
16	22	12	2	2	2	2	2	103.5	103.5
20	22	12	2	2	2	2	2	115	115
25	32	22	12	2	2	2	2	138.5	138.5

Kolben-Ø	S=30 L1-R	S=40 L1-R	S=50 L1-R	S=80 L1-R	S=100 L1-R	S=10 L1-S	S=20 L1-S	S=30 L1-S	S=40 L1-S
8	–	–	–	–	–	101.7	101.7	101.7	101.7
12	111	111	126	172	192	127.9	127.9	127.9	127.9
16	103.5	113.5	128.5	174.5	194.5	114.4	114.4	114.4	124.4
20	115	125	140	185	205	139.9	139.9	139.9	149.9
25	138.5	138.5	151.5	197.5	217.5	162.2	162.2	162.2	162.2

Kolben-Ø	S=50 L1-S	S=80 L1-S	S=100 L1-S	S=10 L2	S=20 L2	S=30 L2	S=40 L2	S=50 L2	S=80 L2
8	121.7	171.7	–	93.5	93.5	93.5	93.5	113.5	163.5
12	142.9	188.9	208.9	98.8	98.8	98.8	98.8	113.8	159.8
16	139.4	185.4	205.4	90.4	90.4	90.4	100.4	115.4	161.4
20	164.9	209.9	229.9	100.5	100.5	100.5	110.5	125.5	170.5
25	175.2	221.2	241.2	121.5	121.5	121.5	121.5	134.5	180.5

Kolben-Ø	S=100 L2	S=10 R1 max.	S=20 R1 max.	S=30 R1 max.	S=40 R1 max.	S=50 R1 max.	S=80 R1 max.	S=100 R1 max.	S=10 R2 max.
8	–	4.2	4.2	4.2	4.2	4.2	4.2	–	4.1
12	179.8	5.7	5.7	5.7	5.7	5.7	5.7	5.7	2
16	181.4	8.7	8.7	8.7	8.7	8.7	8.7	8.7	1.5
20	190.5	12.4	12.4	12.4	12.4	12.4	12.4	12.4	1.5
25	200.5	11.5	11.5	11.5	11.5	10.5	11.5	11.5	7.5

Kolben-Ø	S=20 R2 max.	S=30 R2 max.	S=40 R2 max.	S=50 R2 max.	S=80 R2 max.	S=100 R2 max.
8	4.1	4.1	4.1	4.1	4.1	–
12	2	2	2	10	12	12
16	1.5	1.5	1.5	6	7	5.7
20	1.5	1.5	11.5	9.5	14	14
25	7.5	7.5	7.5	3.3	7.5	9.2

## MSC-08

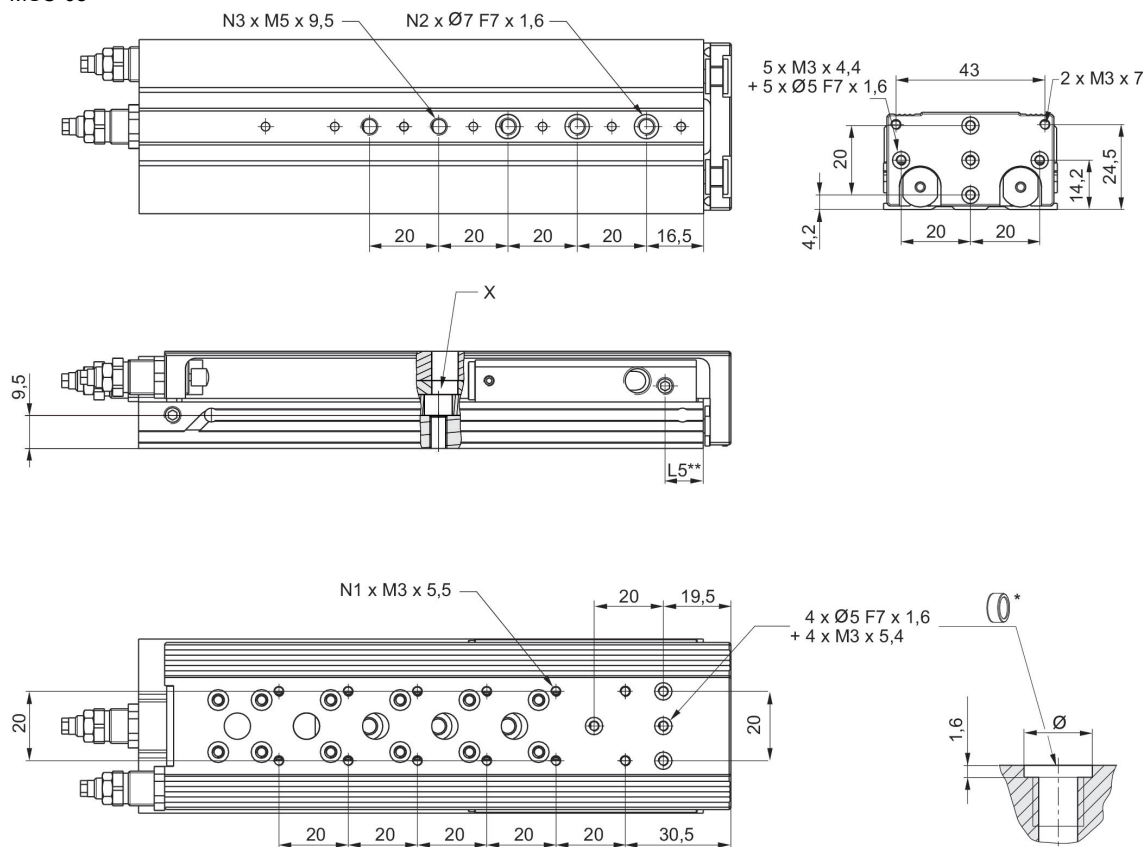

\* = Zentrierringe

\*\* Ø 8 hat eine andere Bezugsfläche.

Materialnummer	Kolben-Ø	S	N1	N2	N3	L5	X
R480643754	8	10	4	2	2	11	
R480643755	8	20	4	2	2	11	
R480643756	8	30	4	2	2	11	
R480643757	8	40	4	2	2	11	
R480643758	8	50	4	3	3	11	1)
R480643759	8	80	8	3	5	11	

S = Hub

1) Zugang zur Durchgangsbohrung erst nach Demontage der Hubbegrenzungsbolzen

## Abmessungen MSC-12

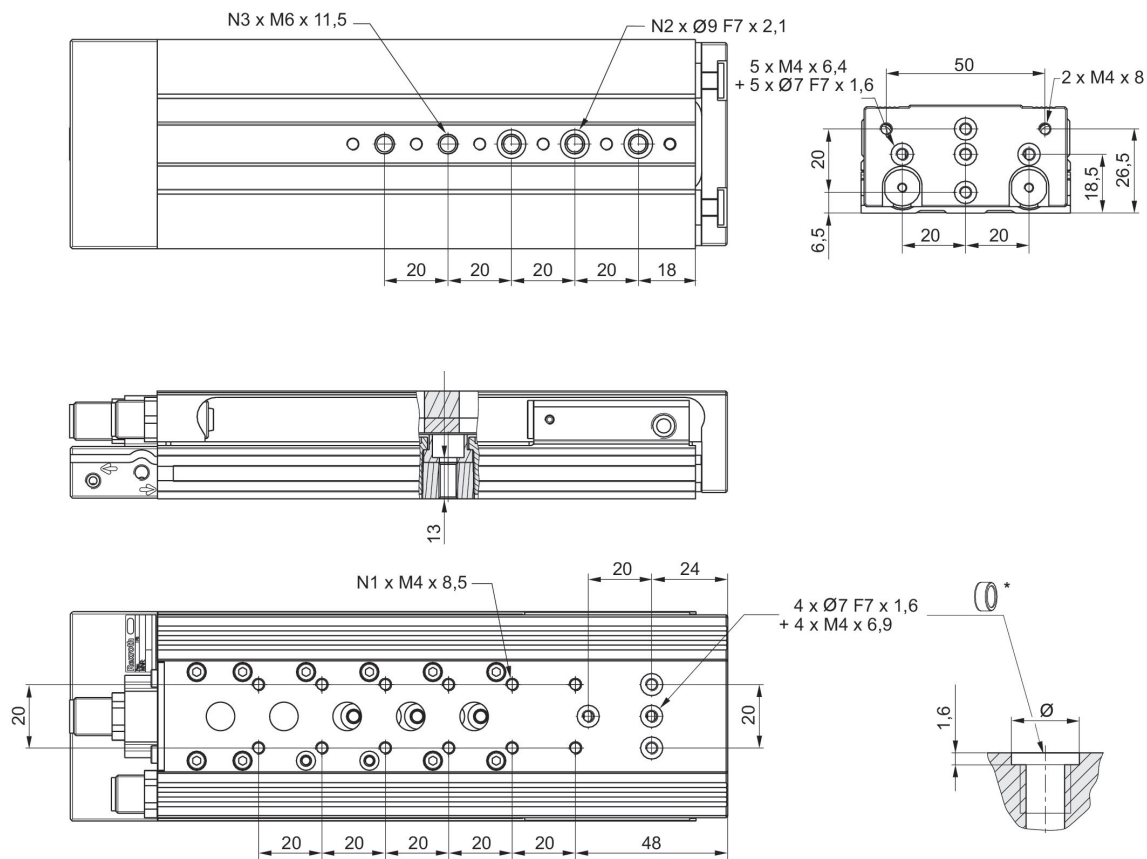

\* = Zentrierringe

Materialnummer	Kolben-Ø	S	N1	N2	N3
R480643760	12	10	2	2	2
R480643761	12	20	2	2	2
R480643762	12	30	2	2	2
R480643763	12	40	2	2	2
R480643764	12	50	4	3	3
R480643765	12	80	6	3	5
R480643766	12	100	8	3	5

S = Hub

## MSC-16

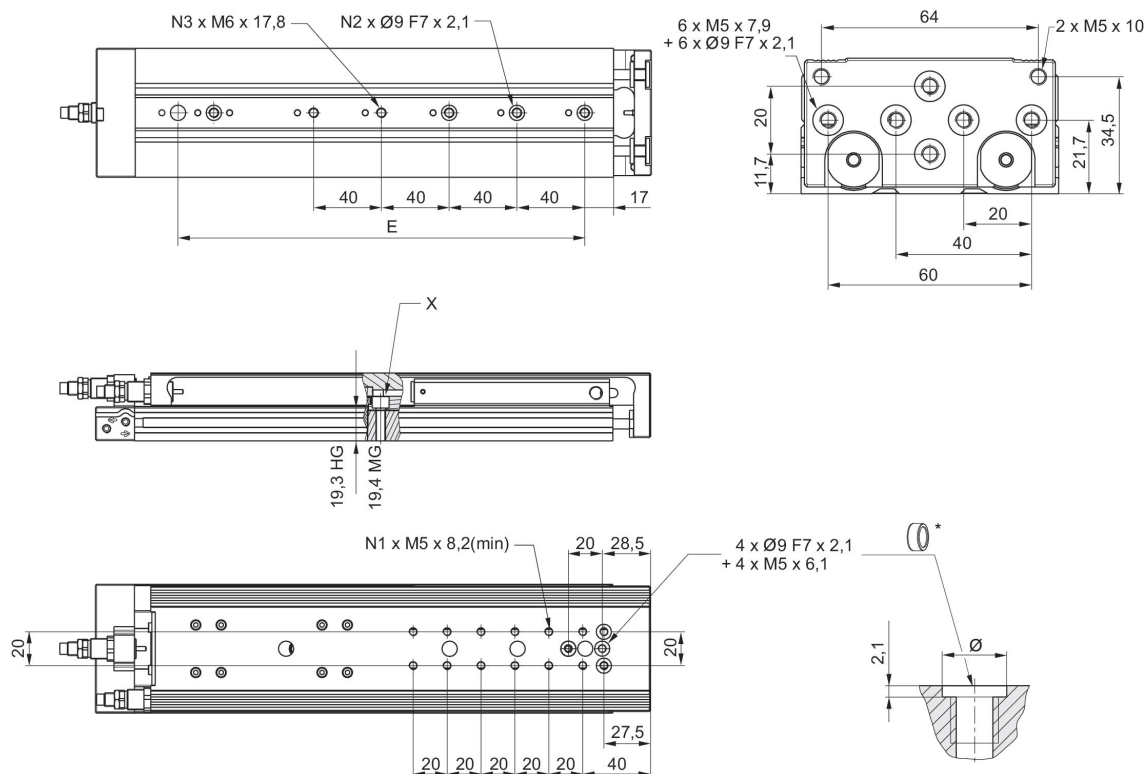

\* = Zentrierringe

Materialnummer	Kolben-Ø	S	N1	N2	N3	X
R480643767	16	10	2	2	2	1)
R480643768	16	20	2	2	2	1)
R480643769	16	30	2	2	2	
R480643770	16	40	4	2	2	
R480643771	16	50	4	2	2	
R480643772	16	80	6	3	3	
R480643773	16	100	8	3	3	

S = Hub

1) Zugang zur Durchgangsbohrung erst nach Demontage der Hubbegrenzungsbolzen

## MSC-20

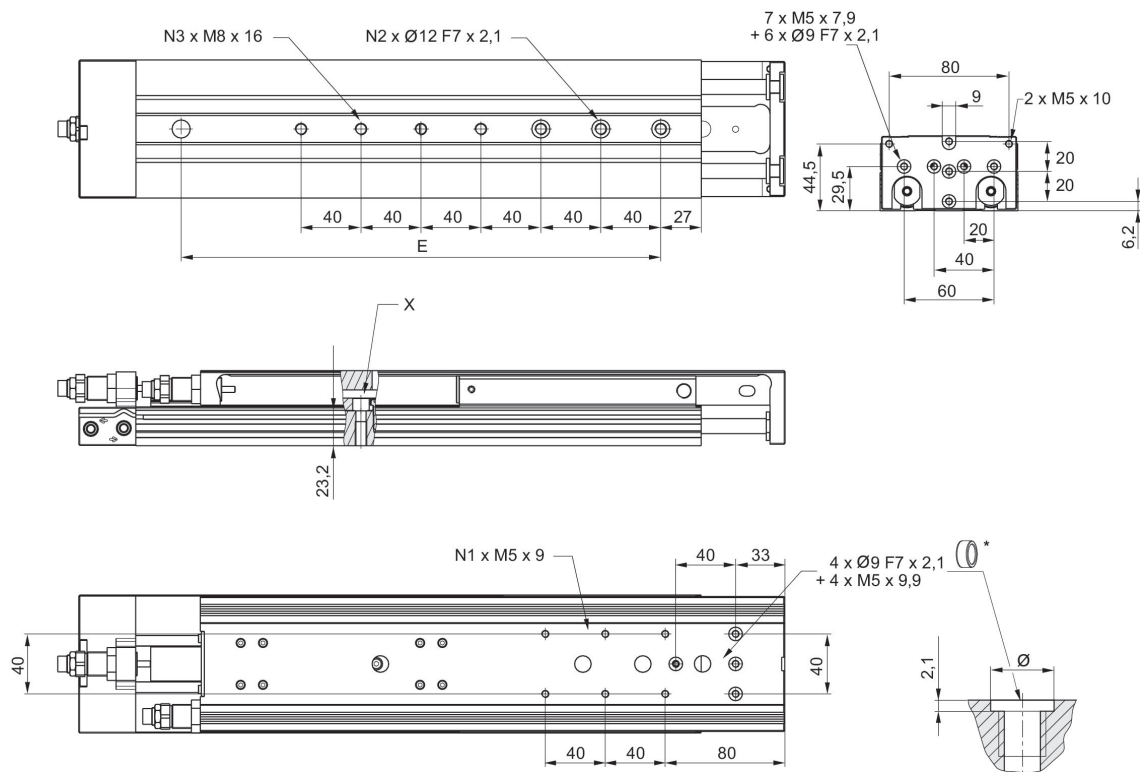

\* = Zentrierringe

Materialnummer	Kolben-Ø	S	N1	N2	N3	X
R480643774	20	10	2	2	2	1)
R480643775	20	20	2	2	2	1)
R480643776	20	30	2	2	2	
R480643777	20	40	2	2	2	
R480643778	20	50	2	2	2	
R480643779	20	80	4	3	3	
R480643780	20	100	4	3	3	

S = Hub

1) Zugang zur Durchgangsbohrung erst nach Demontage der Hubbegrenzungsbolzen

MSC-25

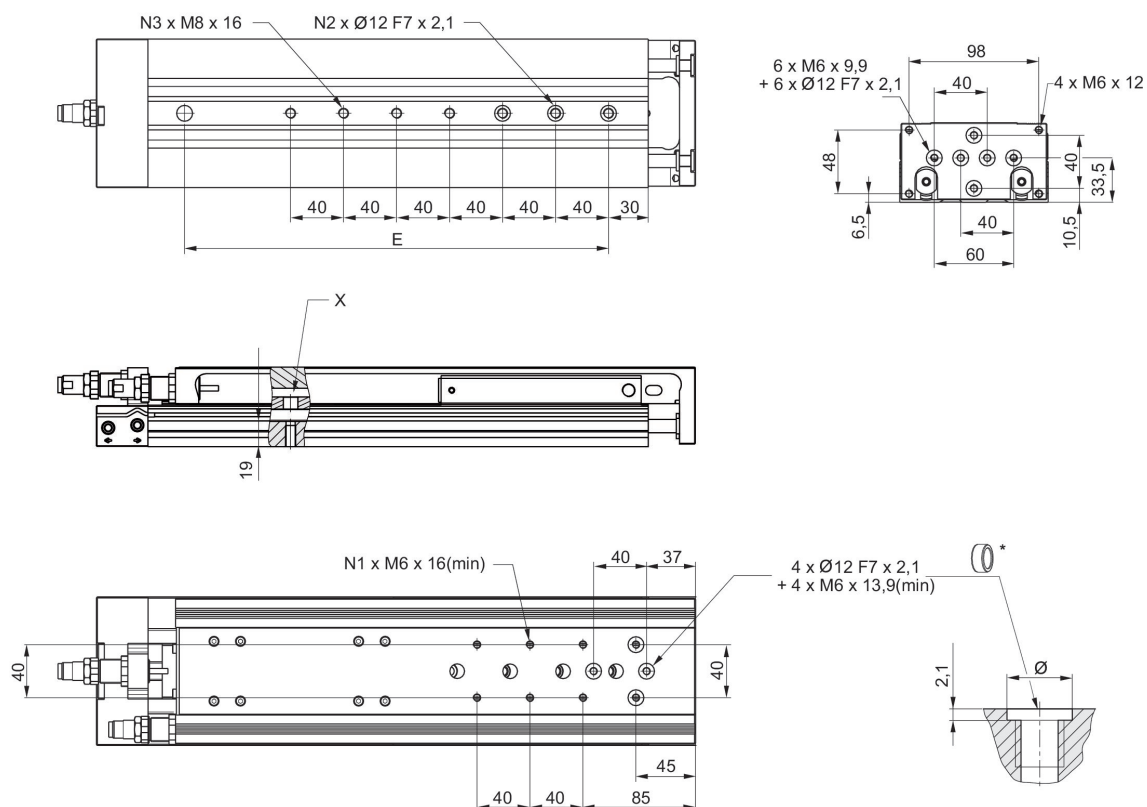

\* = Zentrierringe

Materialnummer	Kolben-Ø	S	N1	N2	N3	X
R480643781	25	10	2	2	2	1)
R480643782	25	20	2	2	2	1)
R480643783	25	30	2	2	2	1)
R480643784	25	40	2	2	2	
R480643785	25	50	4	2	2	
R480643786	25	80	4	3	3	
R480643787	25	100	4	3	3	

S = Hub

1) Zugang zur Durchgangsbohrung erst nach Demontage der Hubbegrenzungsbolzen

Tragfähigkeit

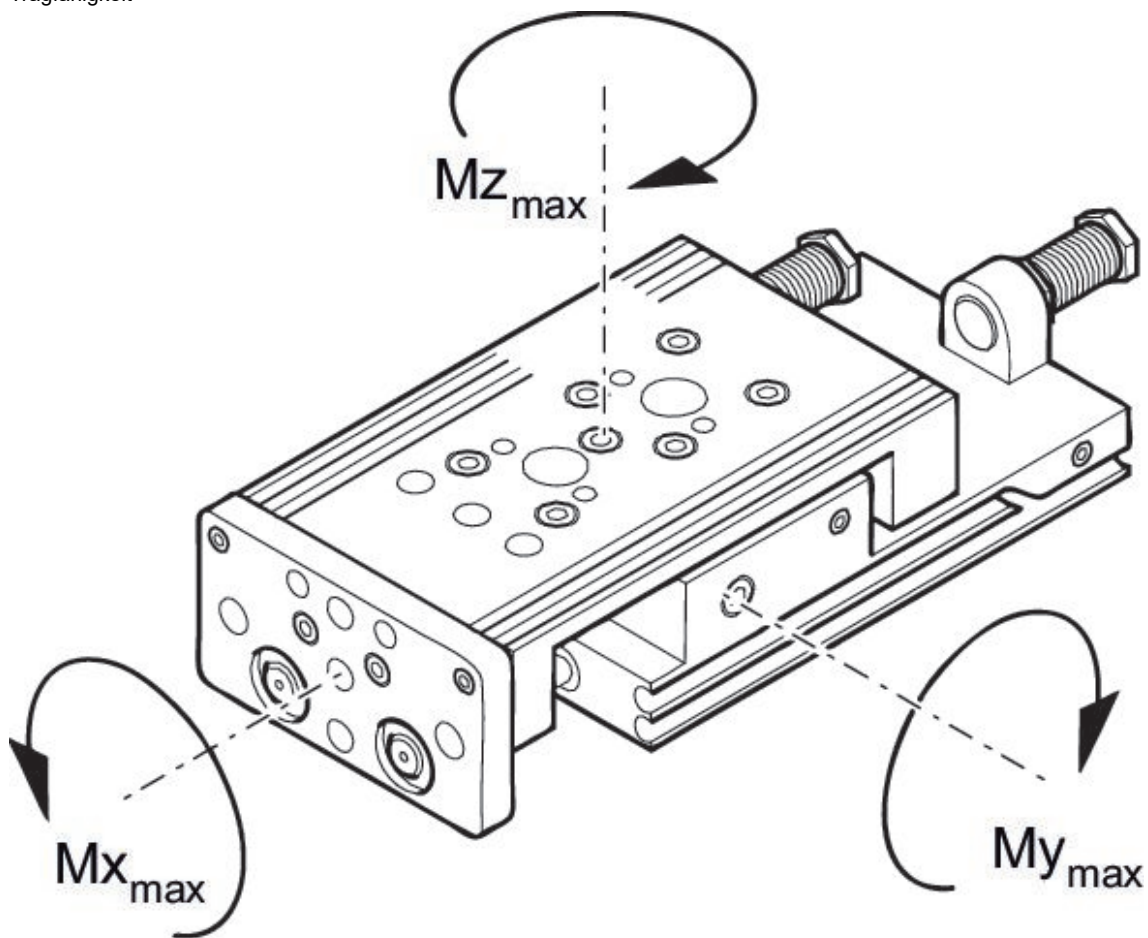

M = max. zulässiges Drehmoment

Korrekturfaktor (a)

Materialnummer	Kolben-Ø	Hub	a [mm]	d [mm]	$M_{x_{max}}$ [Nm]	$M_{y_{max}}$ [Nm]	$M_{z_{max}}$ [Nm]
R480643754	8	10	69.5	12	5.8	5.9	5.9
R480643755	8	20	69.5	12	5.8	5.9	5.9
R480643756	8	30	69.5	12	5.8	5.9	5.9
R480643757	8	40	69.5	12	5.8	5.9	5.9
R480643758	8	50	83	12	5.8	5.9	5.9
R480643759	8	80	121	12	8	14.6	14.6
R480643760	12	10	77	15	13.8	6.45	6.45
R480643761	12	20	77	15	13.8	6.45	6.45
R480643762	12	30	77	15	13.8	6.45	6.45
R480643763	12	40	77	15	13.8	6.45	6.45
R480643764	12	50	81	15	13.8	6.45	6.45
R480643765	12	80	117	15	17.3	15.6	15.6
R480643766	12	100	137	15	17.3	15.6	15.6
R480643767	16	10	65	15	31.6	11.95	11.95
R480643768	16	20	65	15	31.6	11.95	11.95
R480643769	16	30	65	15	31.6	11.95	11.95
R480643770	16	40	75	15	31.6	11.95	11.95
R480643771	16	50	86	15	31.6	11.95	11.95
R480643772	16	80	123	15	45	27.3	27.3
R480643773	16	100	144	15	45	27.3	27.3
R480643774	20	10	75	20	31.6	11.95	11.95
R480643775	20	20	75	20	31.6	11.95	11.95
R480643776	20	30	75	20	31.6	11.95	11.95
R480643777	20	40	75	20	31.6	11.95	11.95
R480643778	20	50	92	20	31.6	11.95	11.95
R480643779	20 20	80	125	20	45	27.3	27.3
R480643780	20	100	143	20	45	27.3	27.3
R480643781	25	10	85	24	87	24.5	24.5
R480643782	25	20	85	24	87	24.5	24.5
R480643783	25	30	85	24	87	24.5	24.5
R480643784	25	40	85	24	87	24.5	24.5
R480643785	25	50	102	24	87	24.5	24.5
R480643786	25	80	134	24	110	62.5	62.5
R480643787	25	100	152	24	110	62.5	62.5

Korrekturfaktor (a, d)

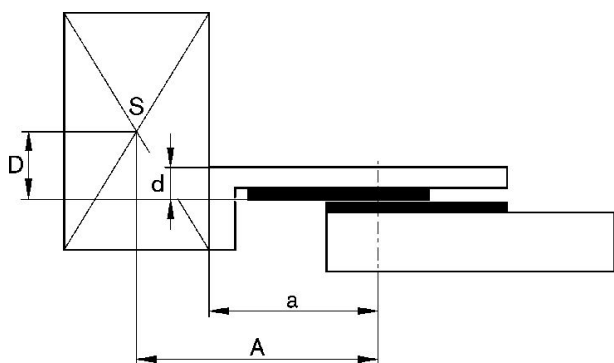

Korrekturfaktor (a, d)

horizontal

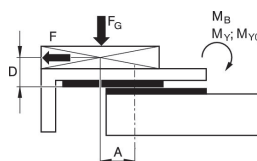

stat.	$M_{B0} = F_G \cdot A + F \cdot D$
dyn.	$M_B = F_G \cdot A$

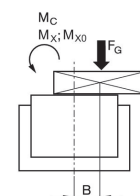

stat.	$M_{C0} = F_G \cdot B$
dyn.	$M_C = F_G \cdot B$

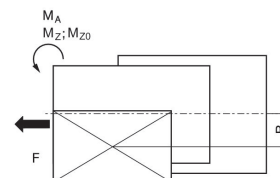

stat.	$M_{A0} = F \cdot B$
dyn.	$M_A = 0$

dyn.	$\frac{M_A}{M_1} + \frac{M_B}{M_2} + \frac{M_C}{M_3} \leq 1$
stat.	$\frac{M_{A0}}{M_{Z0}} + \frac{M_{B0}}{M_{Y0}} + \frac{M_{C0}}{M_{X0}} \leq 1$

$F = m \cdot a$   $FG = m \cdot g$   $a = 1250 \cdot V^2/H$   
 F = Verzögerungskraft [N]  $F_G$  = Gewichtskraft [N] m = Lastmasse [kg] a = Verzögerung [m/s<sup>2</sup>] g = Erdbeschleunigung 9,81 [m/s<sup>2</sup>] V = Geschwindigkeit H = Stoßdämpfers Hublänge [mm]

Korrekturfaktor (a, d)

vertikal

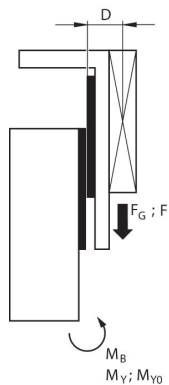

stat.	$M_{B0} = (F_G + F) \cdot D$
dyn.	$M_B = F_G \cdot D$

Maximal bewegte Masse

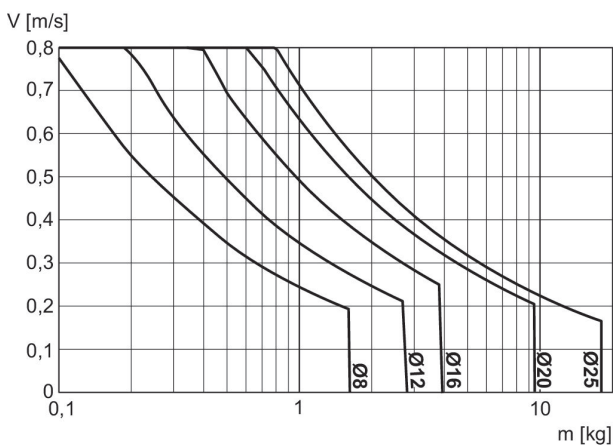

V = Geschwindigkeit [m/s]  
m = Masse

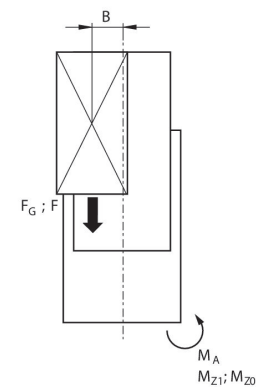

stat.	$M_{A0} = (F_G + F) \cdot B$
dyn.	$M_A = F_G \cdot B$

dyn.	$\frac{M_A}{M_1} + \frac{M_B}{M_2} \leq 1$
stat.	$\frac{M_{A0}}{M_{Z0}} + \frac{M_{B0}}{M_{Y0}} \leq 1$

$F = m \cdot a$   $F_G = m \cdot g$   $a = 1250 \cdot V^2 / H$

F = Verzögerungskraft [N]  $F_G$  = Gewichtskraft [N] m = Lastmasse [kg] a = Verzögerung [m/s<sup>2</sup>] g = Erdbeschleunigung 9,81 [m/s<sup>2</sup>] V = Geschwindigkeit H = Stoßdämpfers Hublänge [mm]

**Korrekturfaktor erforderliche Geschwindigkeit ein- und ausfahrend, horizontal**

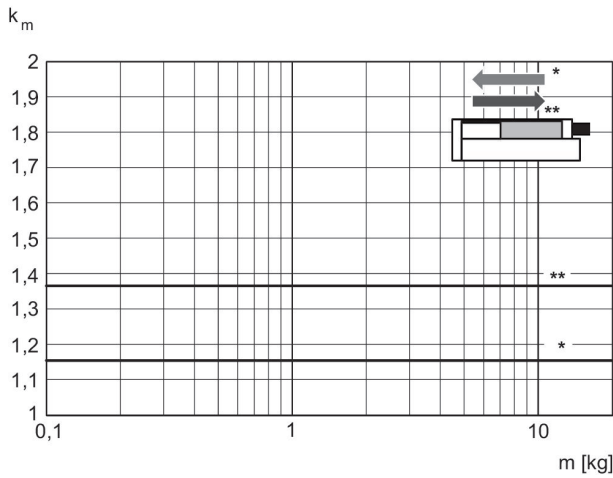

\* einfahrend  
\*\* ausfahrend  
 $V = s/1000 \cdot t \cdot km$   
V = Geschwindigkeit [m/s]  
S = Hub

**Korrekturfaktor erforderliche Geschwindigkeit ausfahrend, vertikal, nach oben**

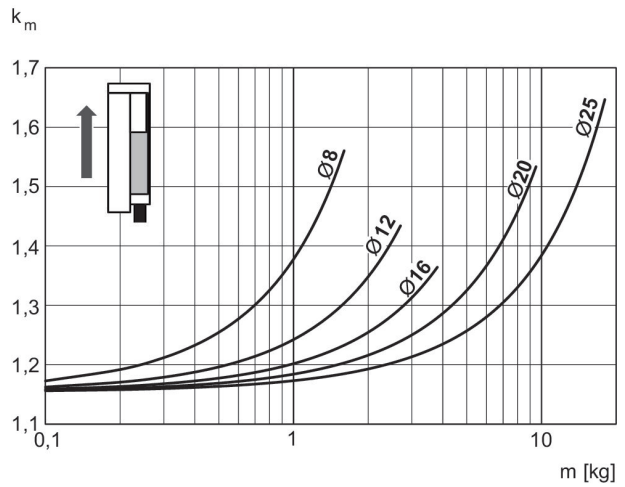

$V = s/1000 \cdot t \cdot km$   
V = Geschwindigkeit [m/s]  
S = Hub [mm]  
t = Zeit [s] für einen Hub  
m = Masse

**Korrekturfaktor erforderliche Geschwindigkeit einfahrend, vertikal, nach oben**

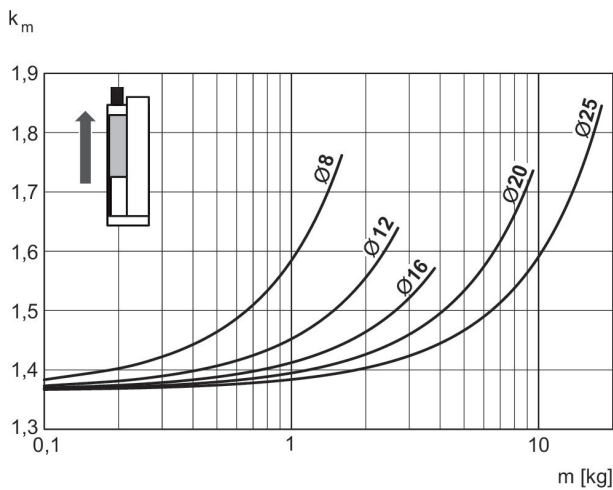

$V = s/1000 \cdot t \cdot km$   
V = Geschwindigkeit [m/s]  
S = Hub [mm]  
t = Zeit [s] für einen Hub  
m = Masse

**Korrekturfaktor erforderliche Geschwindigkeit einfahrend, vertikal, nach unten**

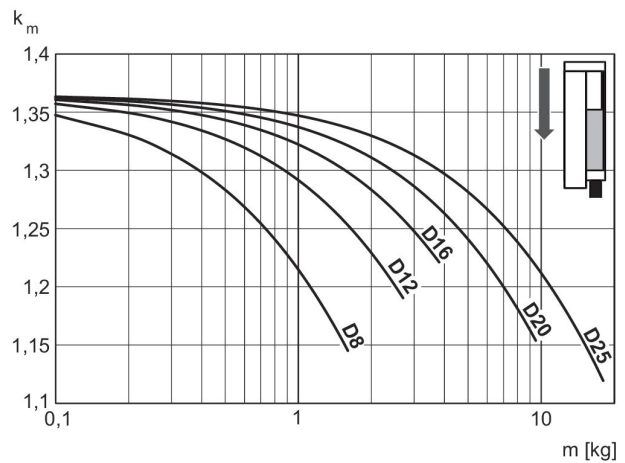

$V = s/1000 \cdot t \cdot km$   
V = Geschwindigkeit [m/s]  
S = Hub [mm]  
t = Zeit [s] für einen Hub  
m = Masse

**Korrekturfaktor erforderliche Geschwindigkeit ausfahrend, vertikal, nach unten**

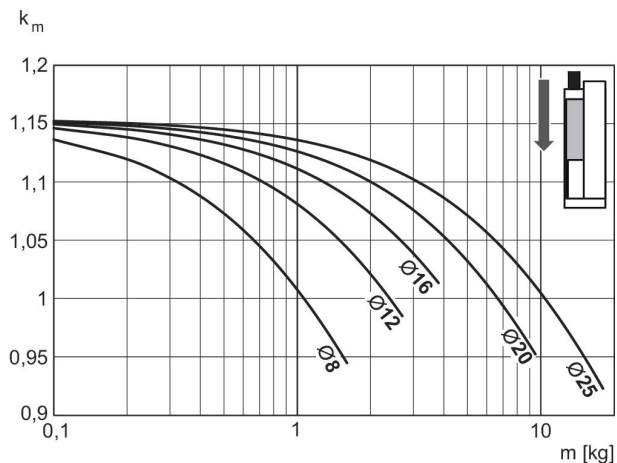

$V = s/1000 \cdot t \cdot km$   
 $V$  = Geschwindigkeit [m/s]  
 $S$  = Hub [mm]  
 $t$  = Zeit [s] für einen Hub  
 $m$  = Masse

**Faktor erreichbare Geschwindigkeit**

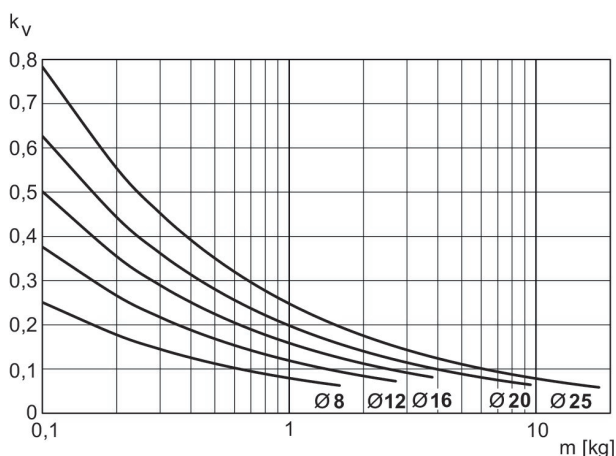

$V = \sqrt{s} \cdot kv$   
 $V$  = Geschwindigkeit [m/s]  
 $S$  = Hub [mm]  
 $m$  = Masse

**Minischlitten, Serie MSC-MG-PM/PE**

Wirkprinzip: doppeltwirkend

Dämpfung: pneumatisch

Easy2Combine: fähig

: mit Magnetkolben

: mit Doppelkolben

: mit integrierter Kugelschienenführung

Umgebungstemperatur min./max.: 0 °C ... 60 °C

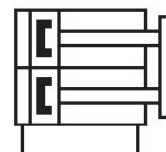

Kolben-Ø	16 mm	20 mm	25 mm
Anschlüsse	M5	G 1/8	G 1/8
Hub 50	R480640154	R480640157	R480640160
80	R480640155	R480640158	R480640161
100	R480640156	R480640159	R480640162

Kolben-Ø	16 mm	20 mm	25 mm
Kolbenkraft einfahrend, theoretisch	218 N	297 N	520 N
Kolbenkraft ausfahrend, theoretisch	182 N	269 N	421 N
Dämpfungsenergie	0.5 J	1.2 J	1.6 J
Dämpfungslänge	7 mm	7 mm	7 mm
Geschwindigkeit max.	0.8 m/s	0.8 m/s	0.8 m/s
Betriebsdruck min./max.	3 bar ... 10 bar	3 bar ... 10 bar	2 bar ... 10 bar

Abmessungen

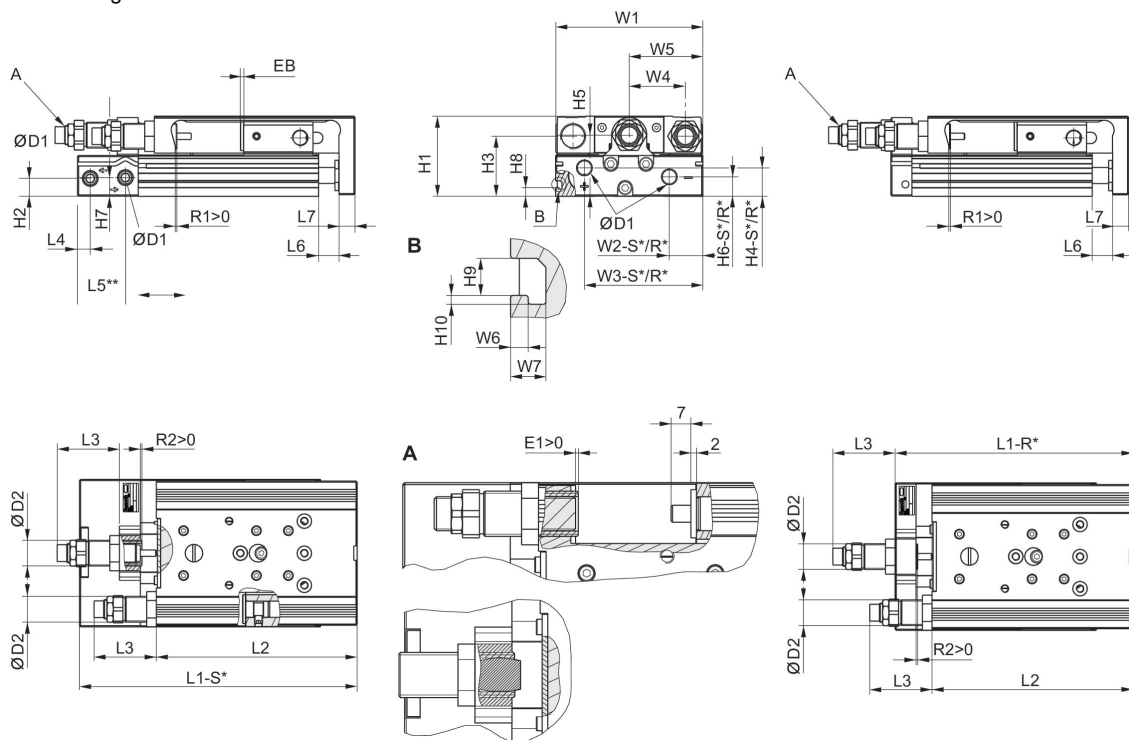

R\*: Bodenausführung mit Luftanschlüssen nur hinten  
S\*: Bodenausführung mit Luftanschlüssen hinten und seitlich

Kolben-Ø	Ø D1	Ø D2	H1	H2	H3	H4-R	H4-S	H5	H6-R
16	M5	M12x1	40	7.2	29	12.2	12.2	31	7.7
20	G 1/8	M16x1,5	50	11.2	37.5	17.3	17.3	38.2	11.7
25	G 1/8	M18x1,5	60	14.2	44	15.5	22.9	46.5	13.2

Kolben-Ø	H6-S	H7	H8	H9	H10	L3 1) max.	L3 2) max.	L4	L5 3)
16	7.7	11.2	-	-	-	12	47	6.5	17.7
20	12.2	11.7	5.5	4.2	1	15	57	8	30
25	21.7	16.2	6.9	5.2	1.5	15	62	9	31

Kolben-Ø	L6	L7	R2	W1	W2-R	W2-S	W3-R	W3-S	W4
16	2	10	3	76	31	31	60.5	60.5	30
20	2.1	10	3	92	10	21	74	74	35
25	2.1	12	3	112	11	14	92	92	44

Kolben-Ø	W5	W6	W7
16	W1/2	-	-
20	W1/2	2	4
25	W1/2	2.5	4.8

## Hubabhängige Maße

Kolben-Ø	S=50 EB	S=80 EB	S=100 EB	S=50 L1-R	S=80 L1-R	S=100 L1-R	S=50 L1-S	S=80 L1-S	S=100 L1-S
16	2	2	2	126.8	172.8	192.8	137.7	183.7	203.7
20	2	2	2	137.9	182.9	202.9	162.8	207.8	227.8
25	2	2	2	149.1	195.1	215.1	172.8	218.8	238.8

Kolben-Ø	S=50 L2	S=80 L2	S=100 L2	S=50 R1 max.	S=80 R1 max.	S=100 R1 max.
16	115.4	161.4	181.4	8.7	8.7	8.7
20	125.5	170.5	190.5	12.4	12.4	12.4
25	134.5	180.5	200.5	10.5	11.5	11.5

### Abmessungen MSC-16

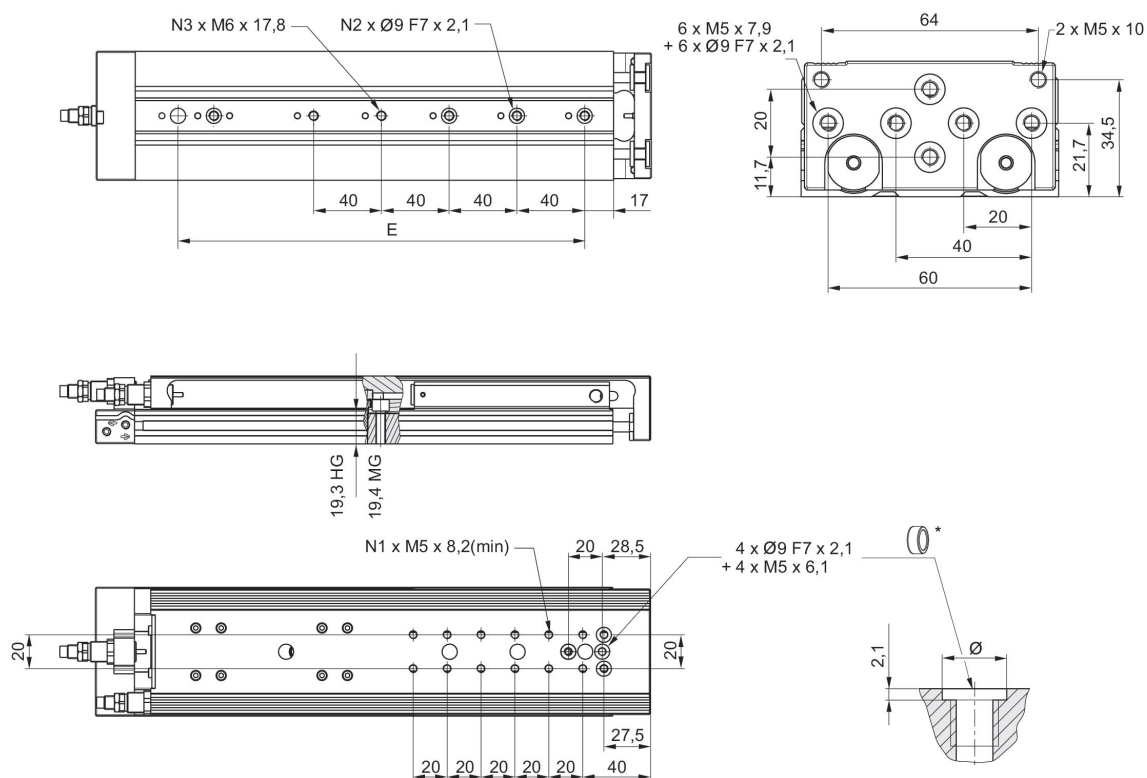

\* = Zentrierringe

Materialnummer	Kolben-Ø	S	N1	N2	N3
R480640154	16	50	4	2	2
R480640155	16	80	6	3	3
R480640156	16	100	8	3	3

S = Hub

## Abmessungen MSC-20

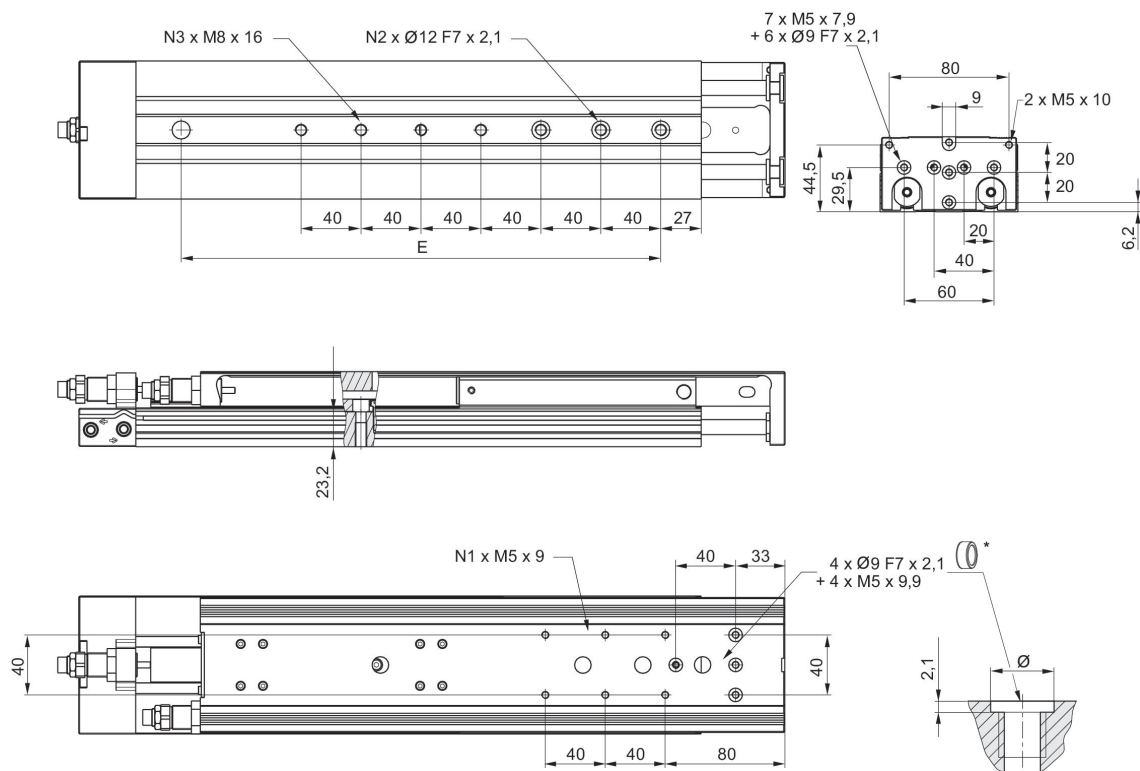

\* = Zentrierringe

Materialnummer	Kolben-Ø	Hub	N1	N2	N3
R480640157	20	50	2	2	2
R480640158	20	80	4	3	3
R480640159	20	100	4	3	3

## Abmessungen MSC-25

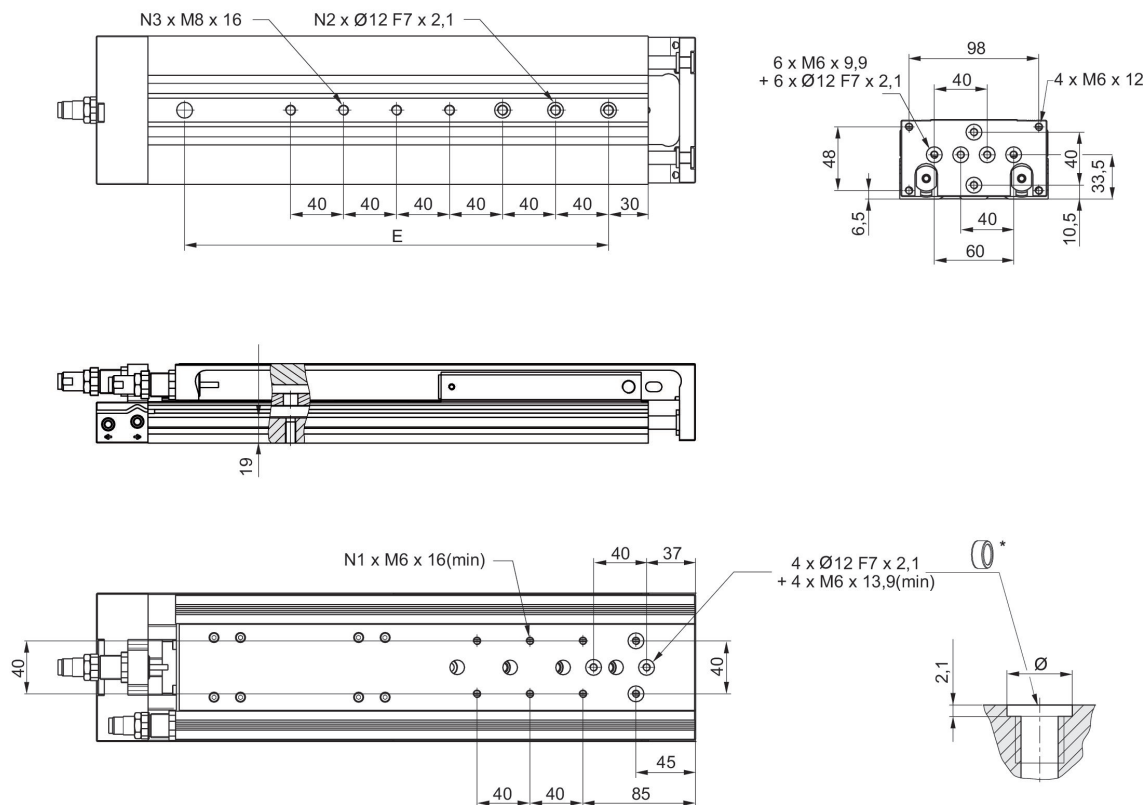

\* = Zentrierringe

Materialnummer	Kolben-Ø	S	N1	N2	N3
R480640160	25	50	4	2	2
R480640161	25	80	4	3	3
R480640162	25	100	4	3	3

S = Hub

Tragfähigkeit

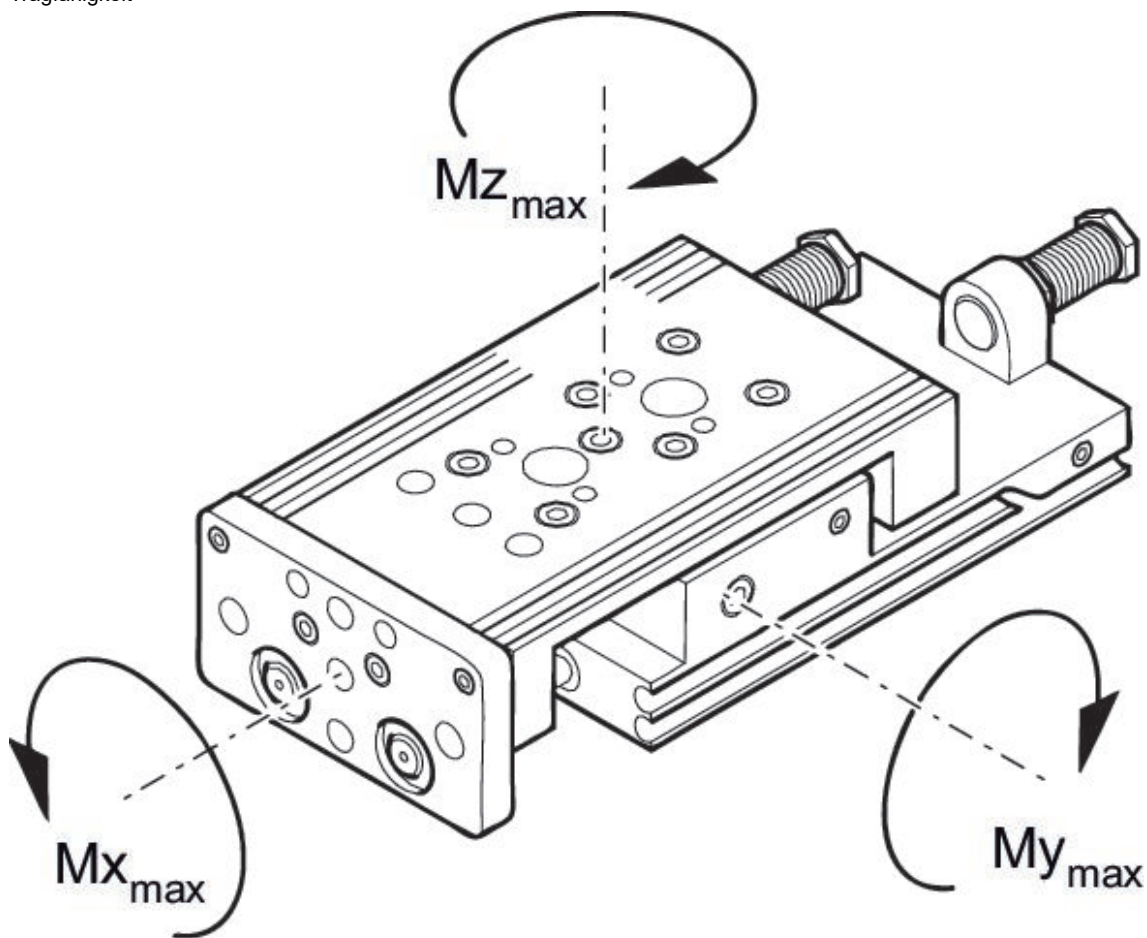

M = max. zulässiges Drehmoment

### Korrekturfaktor (a)

Kolben-Ø	Hub	a [mm]	d [mm]	$M_{x_{max}}$ [Nm]	$M_{y_{max}}$ [Nm]	$M_{z_{max}}$ [Nm]
16	50	86	15	31,6	11,95	11,95
20	50	92	20	31,6	11,95	11,95
25	50	102	24	87	24,5	24,5

Gewicht beweglicher Teile [kg]

Materialnummer	Kolben-Ø	S=10	S=20	S=30	S=40	S=50	S=80	S=100	S=125
R480640154	16	0.375	0.375	0.375	0.4	0.45	0.615	0.65	0.725
R480640155	16	0.375	0.375	0.375	0.4	0.45	0.615	0.65	0.725
R480640156	16	0.375	0.375	0.375	0.4	0.45	0.615	0.65	0.725
R480640157	20	0.655	0.655	0.655	0.69	0.765	0.985	1.035	1.2
R480640158	20	0.655	0.655	0.655	0.69	0.765	0.985	1.035	1.2
R480640159	20	0.655	0.655	0.655	0.69	0.765	0.985	1.035	1.2
R480640160	25	1.1	1.1	1.1	1.1	1.225	1.45	1.625	1.885
R480640161	25	1.1	1.1	1.1	1.1	1.225	1.45	1.625	1.885
R480640162	25	1.1	1.1	1.1	1.1	1.225	1.45	1.625	1.885

Materialnummer	S=150	S=200
R480640154	0.765	–
R480640155	0.765	–
R480640156	0.765	–
R480640157	1.29	1.54
R480640158	1.29	1.54
R480640159	1.29	1.54
R480640160	2.085	2.445
R480640161	2.085	2.445
R480640162	2.085	2.445

S = Hub

Korrekturfaktor (a, d)

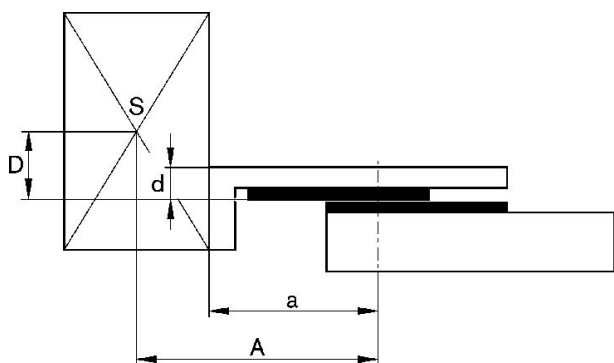

Korrekturfaktor (a, d)

horizontal

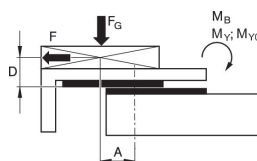

stat.	$M_{B0} = F_G \cdot A + F \cdot D$
dyn.	$M_B = F_G \cdot A$

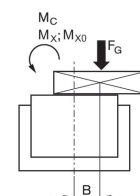

stat.	$M_{C0} = F_G \cdot B$
dyn.	$M_C = F_G \cdot B$

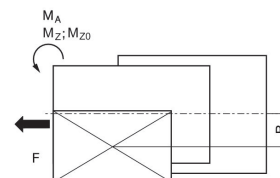

stat.	$M_{A0} = F \cdot B$
dyn.	$M_A = 0$

dyn.	$\frac{M_A}{M_1} + \frac{M_B}{M_2} + \frac{M_C}{M_3} \leq 1$
stat.	$\frac{M_{A0}}{M_{Z0}} + \frac{M_{B0}}{M_{Y0}} + \frac{M_{C0}}{M_{X0}} \leq 1$

$F = m \cdot a$   $FG = m \cdot g$   $a = 1250 \cdot V^2/H$   
 F = Verzögerungskraft [N]  $F_G$  = Gewichtskraft [N] m = Lastmasse [kg] a = Verzögerung [m/s<sup>2</sup>] g = Erdbeschleunigung 9,81 [m/s<sup>2</sup>] V = Geschwindigkeit H = Stoßdämpfers Hublänge [mm]

Korrekturfaktor (a, d)

vertikal

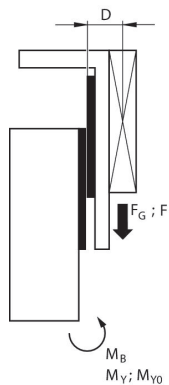

stat.	$M_{B0} = (F_G + F) \cdot D$
dyn.	$M_B = F_G \cdot D$

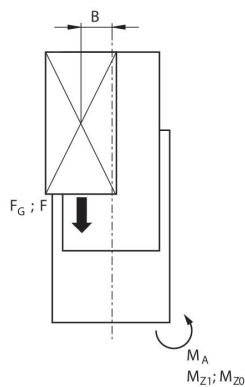

stat.	$M_{A0} = (F_G + F) \cdot B$
dyn.	$M_A = F_G \cdot B$

dyn.	$\frac{M_A}{M_1} + \frac{M_B}{M_2} \leq 1$
stat.	$\frac{M_{A0}}{M_{Z0}} + \frac{M_{B0}}{M_{Y0}} \leq 1$

$F = m \cdot a$   $F_G = m \cdot g$   $a = 1250 \cdot V^2 / H$   
 $F$  = Verzögerungskraft [N]  $F_G$  = Gewichtskraft [N]  $m$  = Lastmasse [kg]  $a$  = Verzögerung [m/s<sup>2</sup>]  $g$  = Erdbeschleunigung 9,81 [m/s<sup>2</sup>]  $V$  = Geschwindigkeit  $H$  = Stoßdämpfers Hublänge [mm]

Maximal bewegte Masse

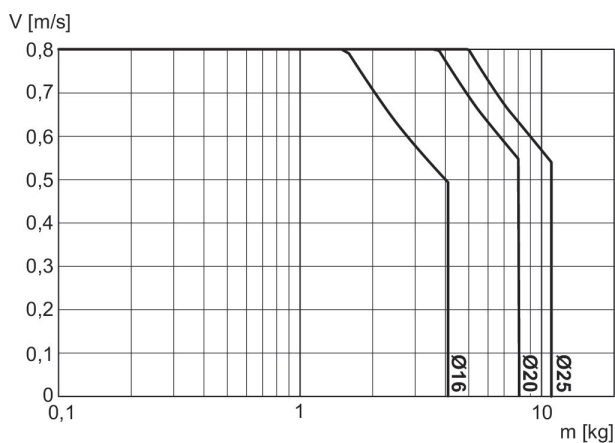

$V$  = Geschwindigkeit [m/s]  
 $m$  = Masse

**Korrekturfaktor erforderliche Geschwindigkeit ein- und ausfahrend, horizontal**

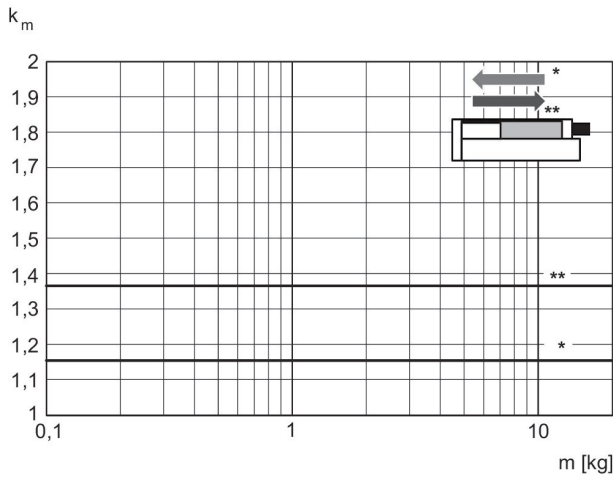

\* einfahrend  
\*\* ausfahrend  
 $V = s/1000 \cdot t \cdot km$   
V = Geschwindigkeit [m/s]  
S = Hub

**Korrekturfaktor erforderliche Geschwindigkeit ausfahrend, vertikal, nach oben**

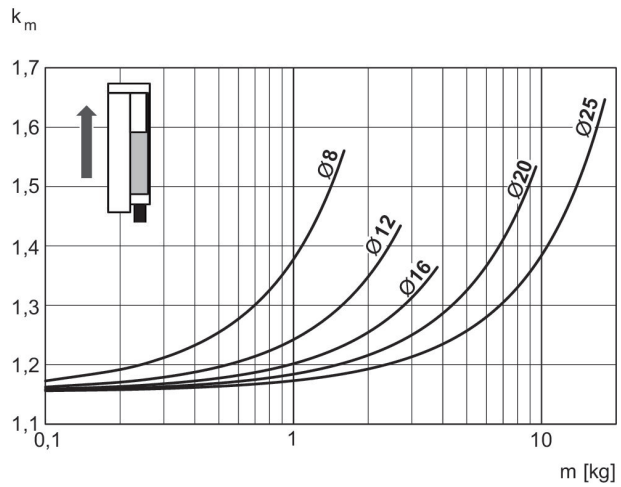

$V = s/1000 \cdot t \cdot km$   
V = Geschwindigkeit [m/s]  
S = Hub [mm]  
t = Zeit [s] für einen Hub  
m = Masse

**Korrekturfaktor erforderliche Geschwindigkeit einfahrend, vertikal, nach oben**

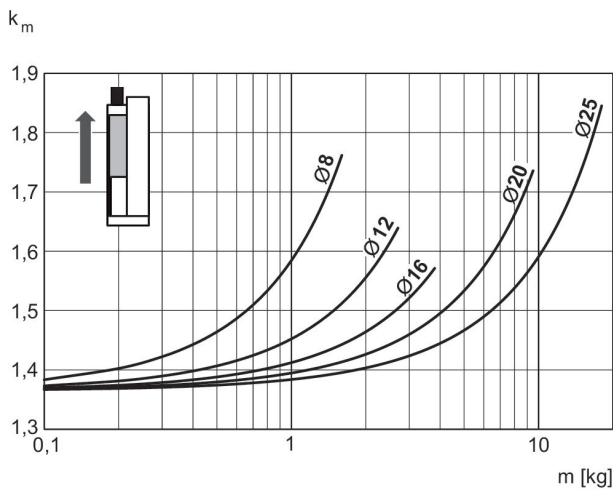

$V = s/1000 \cdot t \cdot km$   
V = Geschwindigkeit [m/s]  
S = Hub [mm]  
t = Zeit [s] für einen Hub  
m = Masse

**Korrekturfaktor erforderliche Geschwindigkeit einfahrend, vertikal, nach unten**

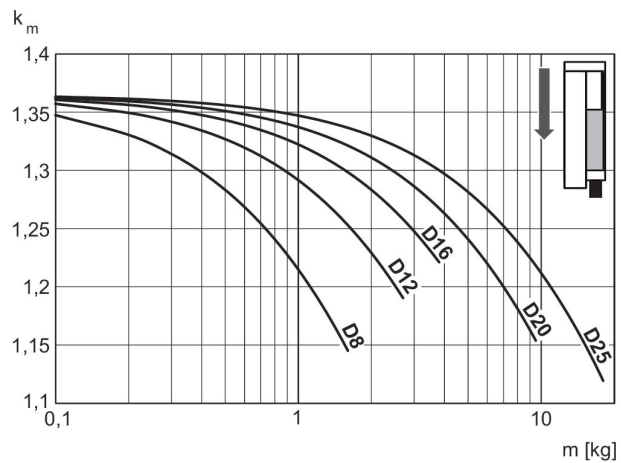

$V = s/1000 \cdot t \cdot km$   
V = Geschwindigkeit [m/s]  
S = Hub [mm]  
t = Zeit [s] für einen Hub  
m = Masse

**Korrekturfaktor erforderliche Geschwindigkeit ausfahrend, vertikal, nach unten**

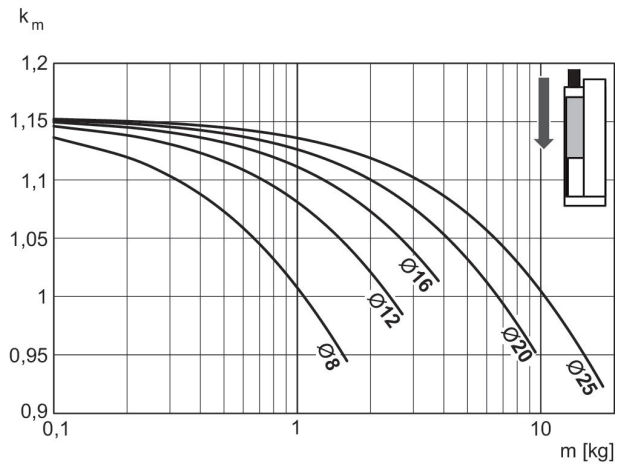

$V = s/1000 \cdot t \cdot km$   
 $V$  = Geschwindigkeit [m/s]  
 $S$  = Hub [mm]  
 $t$  = Zeit [s] für einen Hub  
 $m$  = Masse

**Faktor erreichbare Geschwindigkeit**

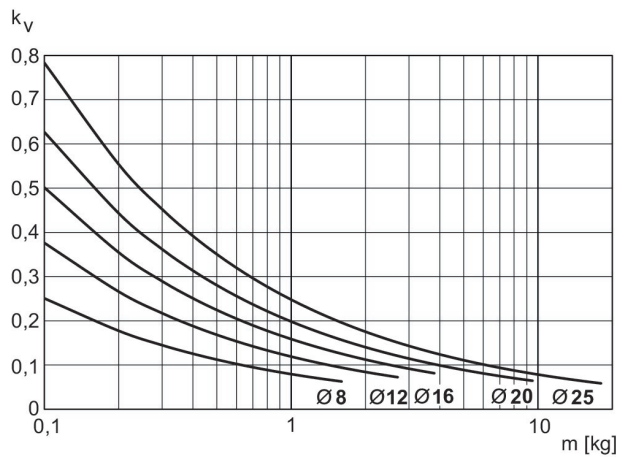

$V = \sqrt{s} \cdot kv$   
 $V$  = Geschwindigkeit [m/s]  
 $S$  = Hub [mm]  
 $m$  = Masse

### Minischlitten, Serie MSC-MG-HM

Wirkprinzip: doppeltwirkend

Dämpfung: hydraulisch

Easy2Combine: fähig

: mit Magnetkolben

: mit Doppelkolben

: mit integrierter Kugelschienenführung

Umgebungstemperatur min./max.: 0 °C ... 60 °C

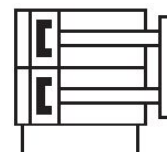

Kolben-Ø	8 mm	12 mm	16 mm	20 mm	25 mm
Anschlüsse	M5	M5	M5	G 1/8	G 1/8
Hub 20	R480640164	-	-	-	-
30	R480640165	R480640171	R480640178	R480640185	R480640192
40	R480640166	R480640172	R480640179	R480640186	R480640193
50	R480640167	R480640173	R480640180	R480640187	R480640194
80	R480640168	R480640174	R480640181	R480640188	R480640195
100	-	R480640175	R480640182	R480640189	R480640196

Kolben-Ø	8 mm	12 mm	16 mm	20 mm	25 mm
Kolbenkraft einfahrend, theoretisch	48 N	107 N	218 N	297 N	520 N
Kolbenkraft ausfahrend, theoretisch	63 N	143 N	253 N	396 N	619 N
Dämpfungsenergie	0.6 J	1 J	1.2 J	3.1 J	5.8 J
Dämpfungslänge	5 mm	7 mm	7 mm	10 mm	14 mm
Geschwindigkeit max.	0.8 m/s	0.8 m/s	0.8 m/s	0.8 m/s	0.8 m/s
Betriebsdruck min./max.	1.5 bar ... 10 bar	1 bar ... 10 bar	1 bar ... 10 bar	1 bar ... 10 bar	1 bar ... 10 bar

Abmessungen

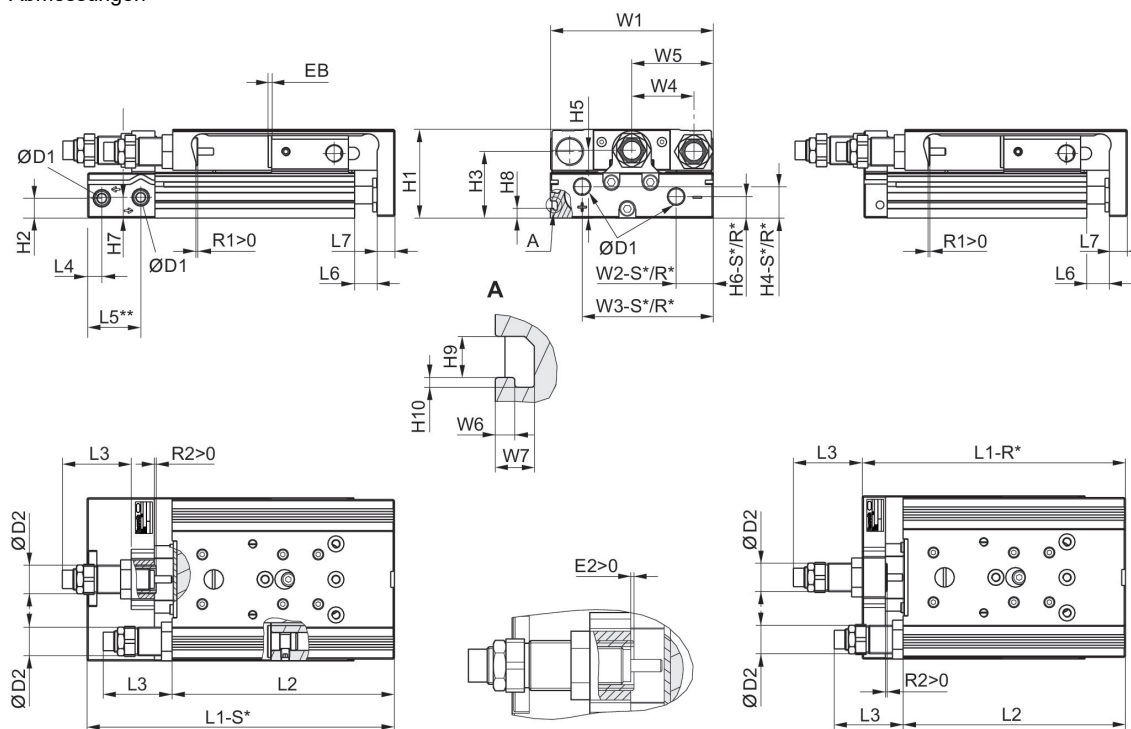

R\*: Bodenausführung mit Luftanschlüssen nur hinten  
S\*: Bodenausführung mit Luftanschlüssen hinten und seitlich  
\*\* Ø 8 hat eine andere Bezugsfläche.

Abmessungen

Kolben-Ø	Ø D1	Ø D2	H1	H2	H3	H4-R	H4-S	H5	H6-R
8	M5	M10x1	28	9.6	20.5	-	7.5	19.5	-
12	M5	M12x1	34	5.7	25	11.2	11.2	24.5	5.7
16	M5	M12x1	40	7.2	29	12.2	12.2	31	7.7
20	G 1/8	M16x1,5	50	11.2	37.5	17.3	17.3	38.2	11.7
25	G 1/8	M18x1,5	60	14.2	44	15.5	22.9	46.5	13.2

Kolben-Ø	H6-S	H7	H8	H9	H10	L3 max.	L4	L5 2)	L6
8	5.5	18	-	-	-	31	9.8	-	1.9
12	5.7	8.3	-	-	-	46.7	7.2	22.5	2
16	7.7	11.2	-	-	-	44.9	6.5	17.7	2
20	12.2	11.7	5.5	4.2	1	48.9	8	30	2.1
25	21.7	16.2	6.9	5.2	1.5	67.7	9	31	2.1

Kolben-Ø	L7	R2	W1	W2-R	W2-S	W3-R	W3-S	W4	W5
8	6	1.9	50.2	-	19.3	-	30.5	18	W1/2
12	8	2	66	28.8	28.8	53	53	24.5	W1/2
16	10	2	76	31	31	60.5	60.5	30	W1/2
20	10	2.1	92	10	21	74	74	35	W1/2
25	12	2.1	112	11	14	92	92	44	W1/2

Kolben-Ø	W6	W7
8	–	–
12	–	–
16	–	–
20	2	4
25	2.5	4.8

## Hubabhängige Maße

Kolben-Ø	S=10 EB	S=20 EB	S=30 EB	S=40 EB	S=50 EB	S=80 EB	S=100 EB	S=10 L1-R	S=20 L1-R
8	32	22	12	2	2	2	–	–	–
12									
16	22	12	2	2	2	2	2	101.8	101.8
20	22	12	2	2	2	2	2	112.9	112.9
25	32	22	12	2	2	2	2	136.1	136.1

Kolben-Ø	S=30 L1-R	S=40 L1-R	S=50 L1-R	S=80 L1-R	S=100 L1-R	S=10 L1-S	S=20 L1-S	S=30 L1-S	S=40 L1-S
8	–	–	–	–	–	100.7	100.7	100.7	100.7
12									
16	101.8	111.8	126.8	172.8	192.8	112.7	112.7	112.7	122.7
20	112.9	122.9	137.9	182.9	202.9	137.8	137.8	137.8	147.8
25	136.1	136.1	149.1	195.1	215.1	159.8	159.8	159.8	159.8

Kolben-Ø	S=50 L1-S	S=80 L1-S	S=100 L1-S	S=10 L2	S=20 L2	S=30 L2	S=40 L2	S=50 L2	S=80 L2
8	120.7	170.7	–	93.5	93.5	93.5	93.5	113.5	163.5
12									
16	137.7	183.7	203.7	90.4	90.4	90.4	100.4	115.4	161.4
20	162.8	207.8	227.8	100.5	100.5	100.5	110.5	125.5	170.5
25	172.8	218.8	238.8	121.5	121.5	121.5	121.5	134.5	180.5

Kolben-Ø	S=100 L2	S=10 R1 max.	S=20 R1 max.	S=30 R1 max.	S=40 R1 max.	S=50 R1 max.	S=80 R1 max.	S=100 R1 max.	S=10 R2 max.
8	–	4.2	4.2	4.2	4.2	4.2	4.2	–	4.1
12									
16	181.4	8.7	8.7	8.7	8.7	8.7	8.7	8.7	1.5
20	190.5	12.4	12.4	12.4	12.4	12.4	12.4	12.4	1.5
25	200.5	11.5	11.5	11.5	11.5	10.5	11.5	11.5	7.5

Kolben-Ø	S=20 R2 max.	S=30 R2 max.	S=40 R2 max.	S=50 R2 max.	S=80 R2 max.	S=100 R2 max.
8	4.1	4.1	4.1	4.1	4.1	–
12						
16	1.5	1.5	1.5	6	7	5.7
20	1.5	1.5	11.5	9.5	14	14
25	7.5	7.5	7.5	3.3	7.5	9.2

Gewicht beweglicher Teile [kg]

Kolben-Ø	S=10	S=20	S=30	S=40	S=50	S=80	S=100	S=125	S=150
8	0.165	0.165	0.165	0.165	0.195	0.265	–	–	–
12	0.28	0.28	0.28	0.28	0.315	0.403	0.46	–	–
16	0.375	0.375	0.375	0.4	0.45	0.615	0.65	0.725	0.765
20	0.655	0.655	0.655	0.69	0.765	0.985	1.035	1.2	1.29
25	1.1	1.1	1.1	1.1	1.225	1.45	1.625	1.885	2.085

Kolben-Ø	S=200
8	–
12	–
16	–
20	1.54
25	2.445

## MSC-08

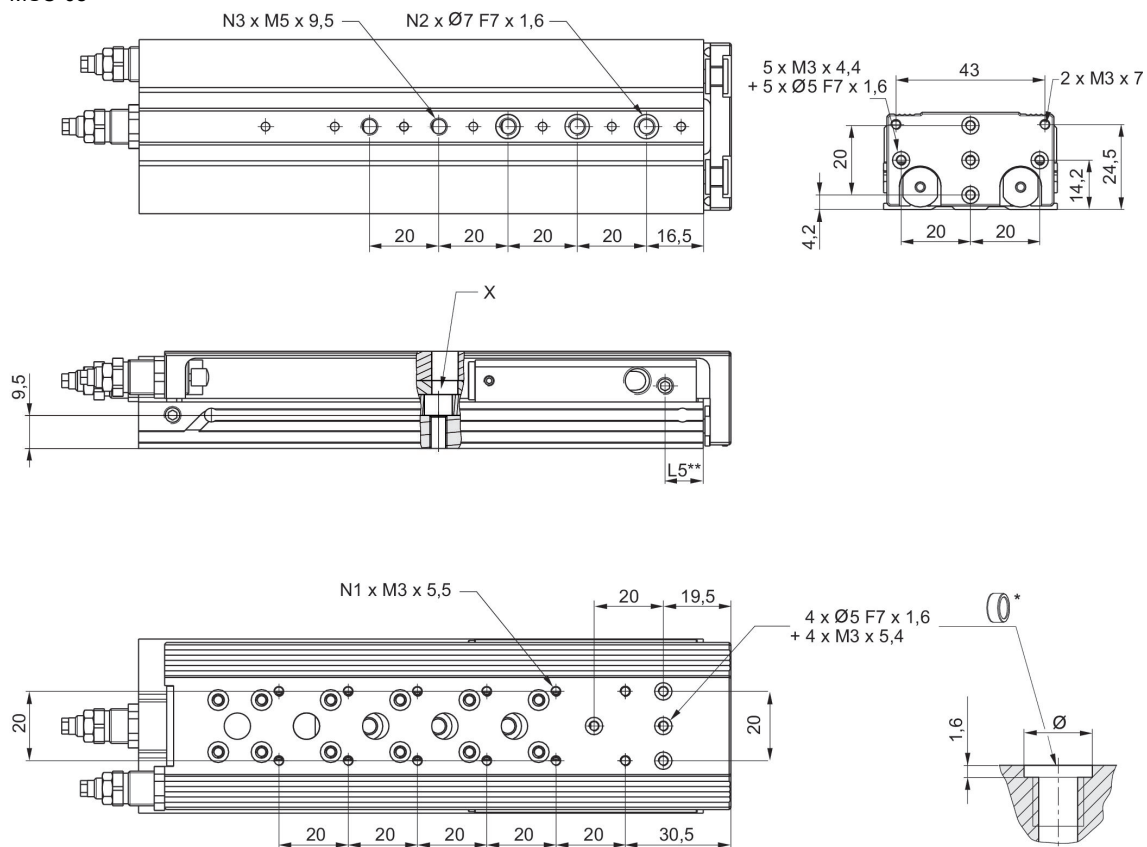

\* = Zentrierringe  
\*\* Ø 8 hat eine andere Bezugsfläche.

Materialnummer	Kolben-Ø	S	N1	N2	N3	L5	X
R480640164	8	20	4	2	2	11	
R480640165	8	30	4	2	2	11	
R480640166	8	40	6	2	2	11	
R480640167	8	50	8	3	3	11	1)
R480640168	8	80	12	3	5	11	

S = Hub

1) Zugang zur Durchgangsbohrung erst nach Demontage der Hubbegrenzungsbolzen

## Abmessungen MSC-12

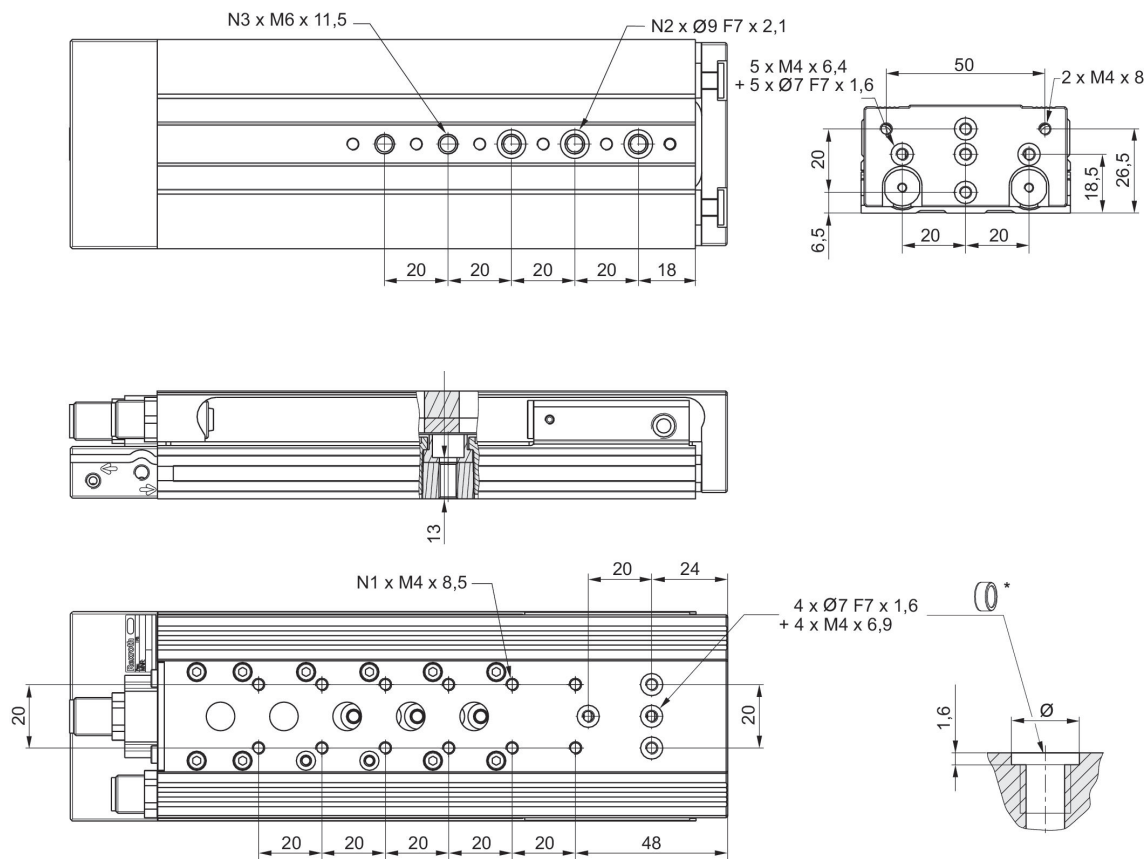

\* = Zentrierringe

Materialnummer	Kolben-Ø	S	N1	N2	N3
R480640171	12	30	2	2	2
R480640172	12	40	2	2	2
R480640173	12	50	4	3	3
R480640174	12	80	6	3	5
R480640175	12	100	8	3	5

S = Hub

Abmessungen  
MSC-16

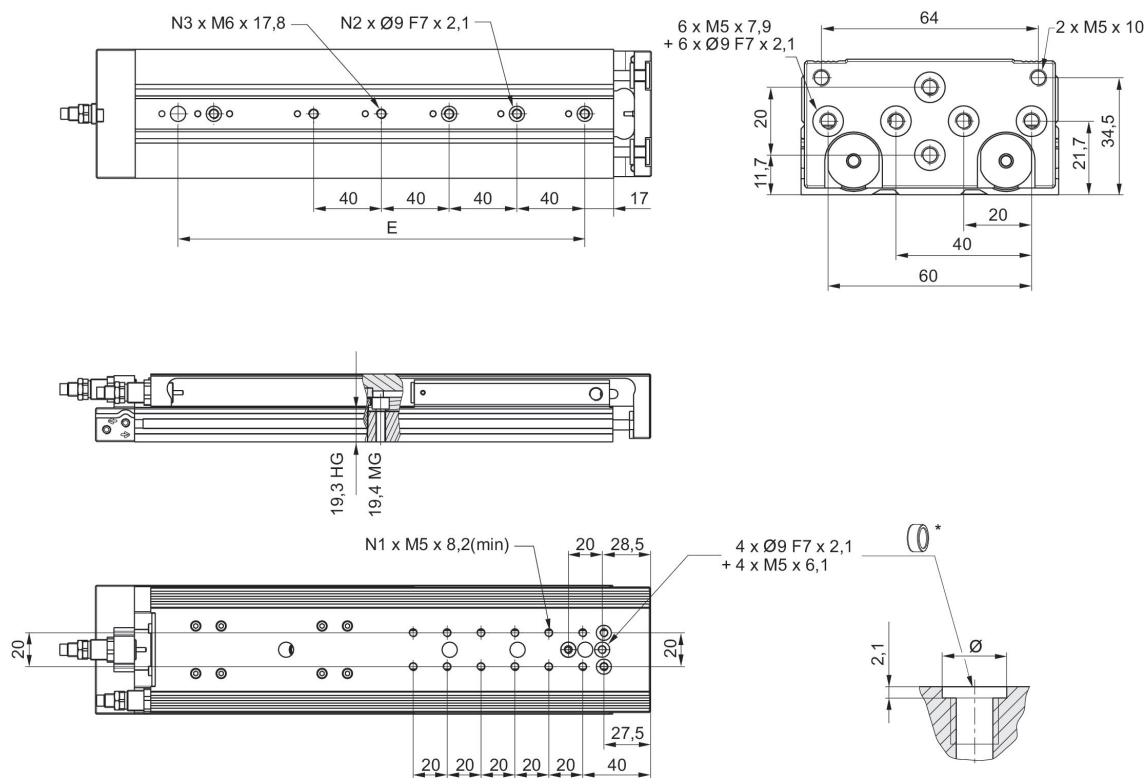

\* = Zentrierringe

Materialnummer	Kolben-Ø	S	N1	N2	N3	X
R480640178	16	30	2	2	2	
R480640179	16	40	4	2	2	
R480640180	16	50	4	2	2	
R480640181	16	80	6	3	3	
R480640182	16	100	8	3	3	

S = Hub  
1) Zugang zur Durchgangsbohrung erst nach Demontage der Hubbegrenzungsbolzen

## Abmessungen MSC-20

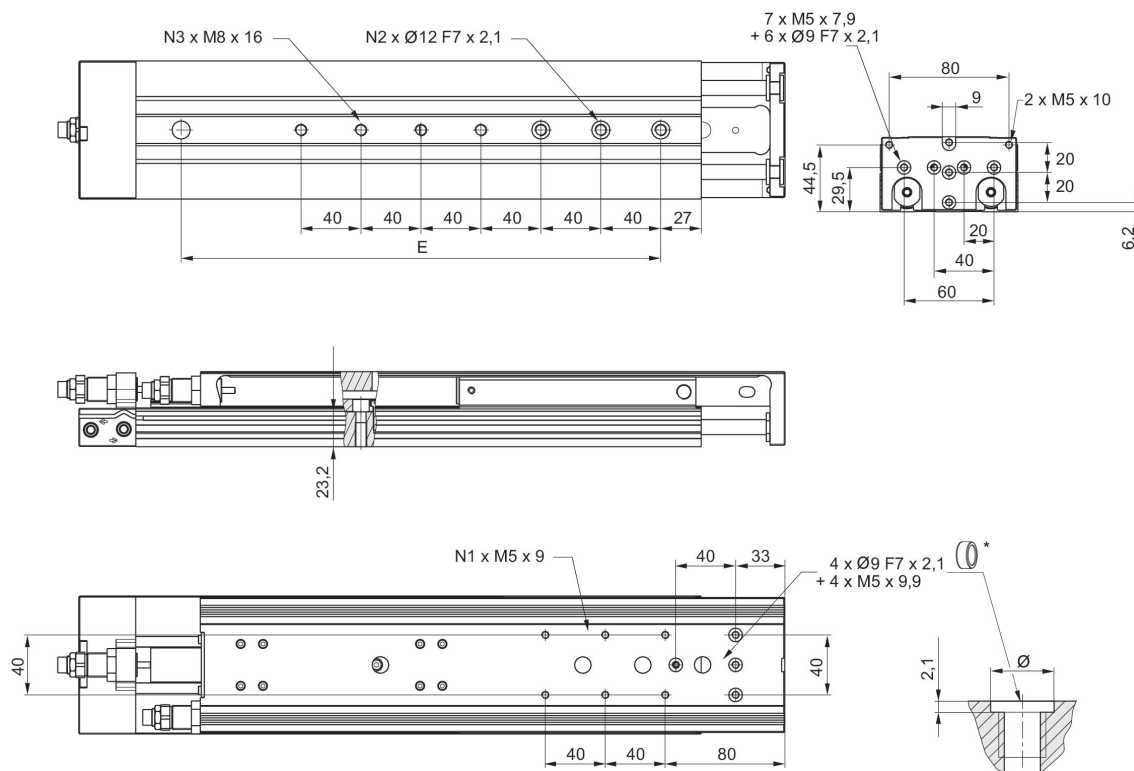

\* = Zentrierringe

Materialnummer	Kolben-Ø	Hub	N1	N2	N3
R480640185	20	30	2	2	2
R480640186	20	40	2	2	2
R480640187	20	50	2	2	2
R480640188	20	80	4	3	3
R480640189	20	100	4	3	3

MSC-25

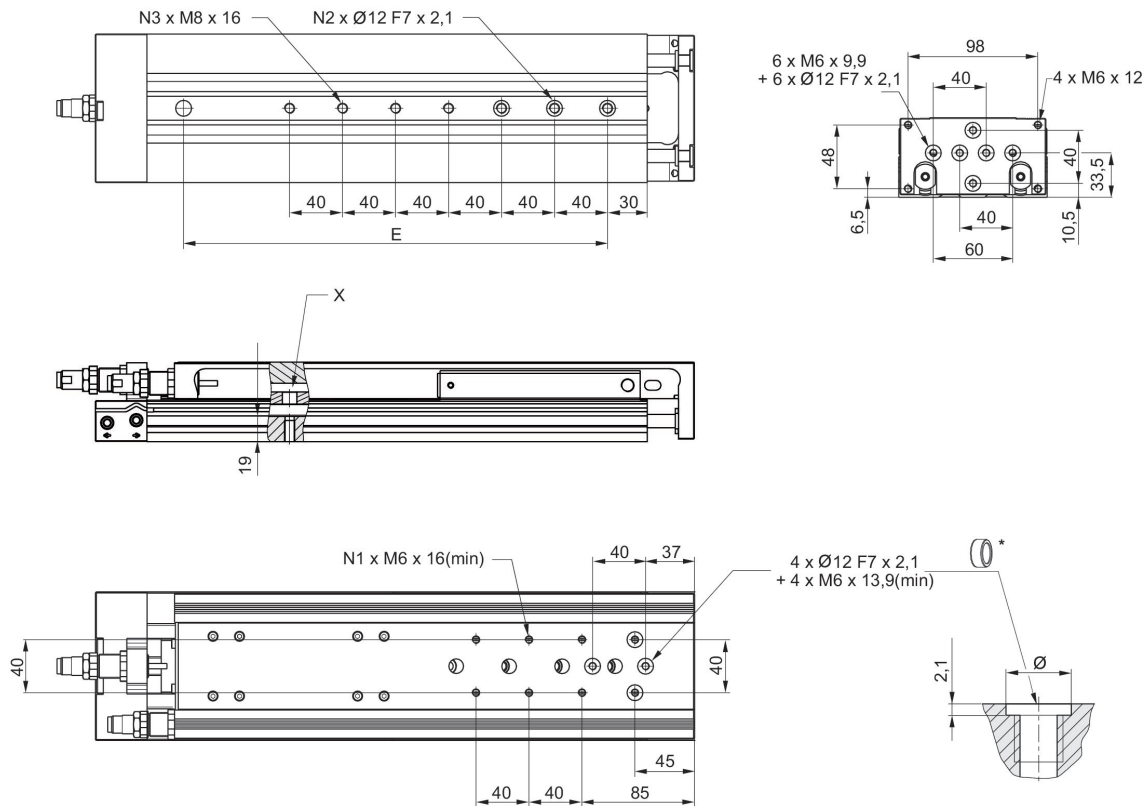

\* = Zentrierringe

Materialnummer	Kolben-Ø	S	N1	N2	N3	X
R480640192	25	30	2	2	2	1)
R480640193	25	40	2	2	2	
R480640194	25	50	4	2	2	
R480640195	25	80	4	3	3	
R480640196	25	100	4	3	3	

S = Hub

1) Zugang zur Durchgangsbohrung erst nach Demontage der Hubbegrenzungsbolzen

Tragfähigkeit

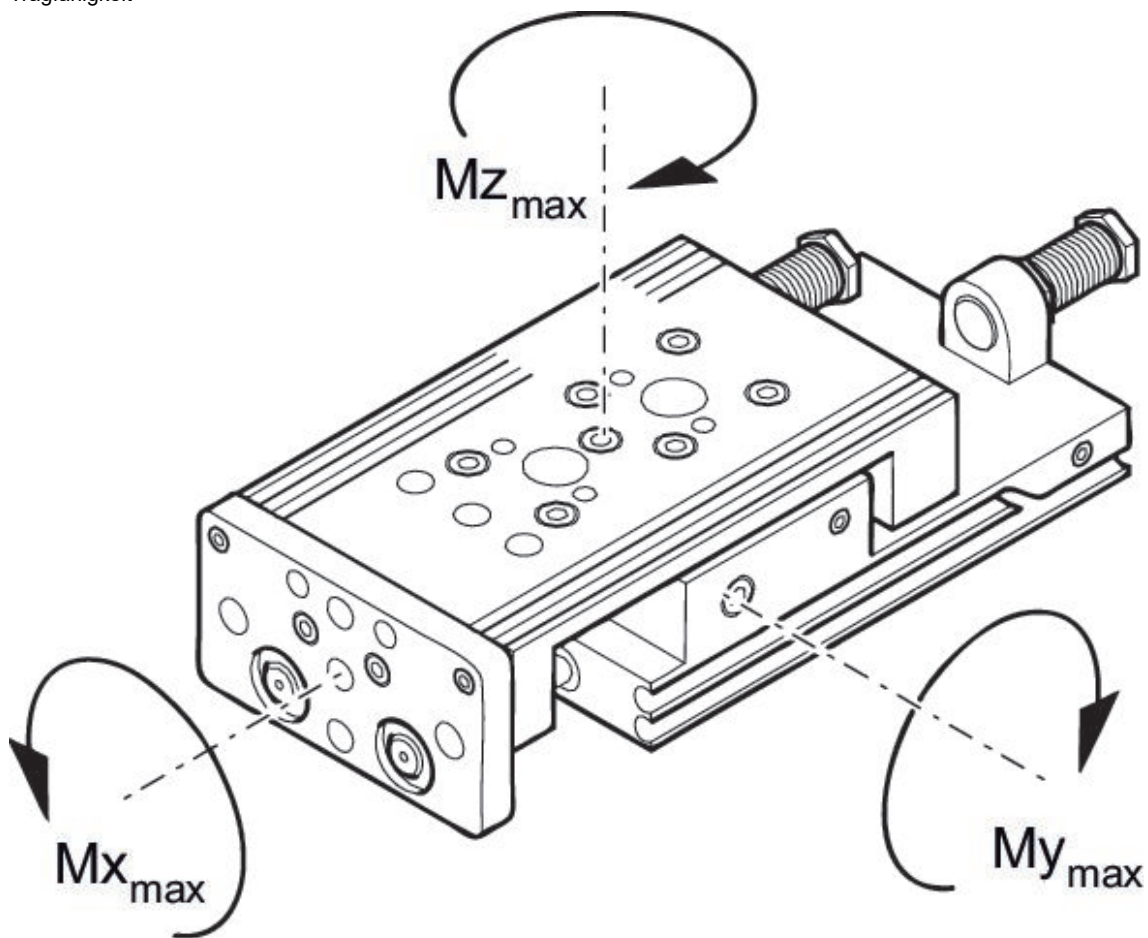

M = max. zulässiges Drehmoment

## Korrekturfaktor (a)

Materialnummer	Kolben-Ø	Hub	a [mm]	d [mm]	$M_{x_{max}}$ [Nm]	$M_{y_{max}}$ [Nm]	$M_{z_{max}}$ [Nm]
R480640164	8	20	69.5	12	5.8	5.9	5.9
R480640165	8	30	69.5	12	5.8	5.9	5.9
R480640166	8	40	69.5	12	5.8	5.9	5.9
R480640167	8	50	83	12	5.8	5.9	5.9
R480640168	8	80	121	12	8	14.6	14.6
R480640171	12	30	77	15	13.8	6.45	6.45
R480640172	12	40	77	15	13.8	6.45	6.45
R480640173	12	50	81	15	13.8	6.45	6.45
R480640174	12	80	117	15	17.3	15.6	15.6
R480640175	12	100	137	15	17.3	15.6	15.6
R480640178	16	30	65	15	31.6	11.95	11.95
R480640179	16	40	75	15	31.6	11.95	11.95
R480640180	16	50	86	15	31.6	11.95	11.95
R480640181	16	80	123	15	45	27.3	27.3
R480640182	16	100	144	15	45	27.3	27.3
R480640185	20	30	75	20	31.6	11.95	11.95
R480640186	20	40	75	20	31.6	11.95	11.95
R480640187	20	50	92	20	31.6	11.95	11.95
R480640188	20	80	125	20	45	27.3	27.3
R480640189	20	100	143	20	45	27.3	27.3
R480640192	25	30	85	24	87	24.5	24.5
R480640193	25	40	85	24	87	24.5	24.5
R480640194	25	50	102	24	87	24.5	24.5
R480640195	25	80	134	24	110	62.5	62.5
R480640196	25	100	152	24	110	62.5	62.5

Materialnummer	Kolben-Ø	S	N1	N2	N3	X
R480640185	20	30	2	2	2	
R480640186	20	40	2	2	2	
R480640187	20	50	2	2	2	
R480640188	20	80	4	3	3	
R480640189	20	100	4	3	3	

S = Hub

1) Zugang zur Durchgangsbohrung erst nach Demontage der Hubbegrenzungsbolzen

Korrekturfaktor (a, d)

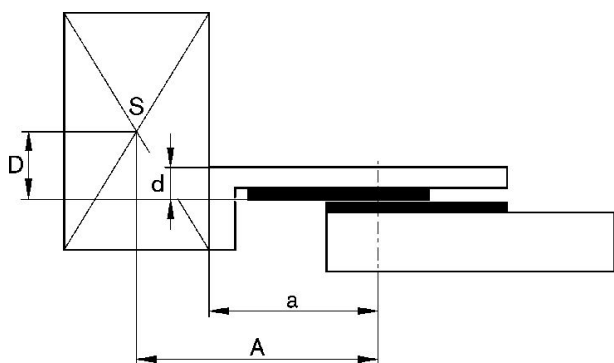

Korrekturfaktor (a, d)

horizontal

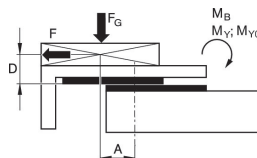

stat.	$M_{B0} = F_G \cdot A + F \cdot D$
dyn.	$M_B = F_G \cdot A$

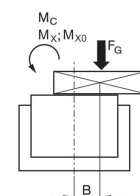

stat.	$M_{C0} = F_G \cdot B$
dyn.	$M_C = F_G \cdot B$

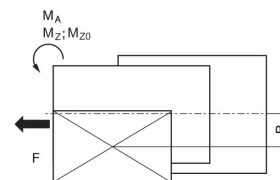

stat.	$M_{A0} = F \cdot B$
dyn.	$M_A = 0$

dyn.	$\frac{M_A}{M_1} + \frac{M_B}{M_2} + \frac{M_C}{M_3} \leq 1$
stat.	$\frac{M_{A0}}{M_{Z0}} + \frac{M_{B0}}{M_{Y0}} + \frac{M_{C0}}{M_{X0}} \leq 1$

$F = m \cdot a$   $FG = m \cdot g$   $a = 1250 \cdot V^2/H$   
 $F$  = Verzögerungskraft [N]  $F_G$  = Gewichtskraft [N]  $m$  = Lastmasse [kg]  $a$  = Verzögerung [m/s<sup>2</sup>]  $g$  = Erdbeschleunigung 9,81 [m/s<sup>2</sup>]  $V$  = Geschwindigkeit  $H$  = Stoßdämpfers Hublänge [mm]

Korrekturfaktor (a, d)

vertikal

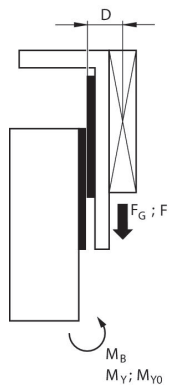

stat.	$M_{B0} = (F_G + F) \cdot D$
dyn.	$M_B = F_G \cdot D$

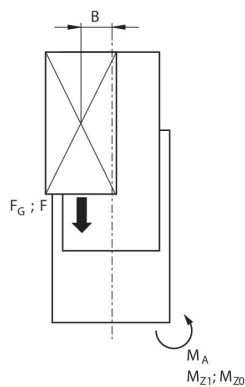

stat.	$M_{A0} = (F_G + F) \cdot B$
dyn.	$M_A = F_G \cdot B$

dyn.	$\frac{M_A}{M_1} + \frac{M_B}{M_2} \leq 1$
stat.	$\frac{M_{A0}}{M_{Z0}} + \frac{M_{B0}}{M_{Y0}} \leq 1$

$F = m \cdot a$   $F_G = m \cdot g$   $a = 1250 \cdot V^2 / H$   
 $F$  = Verzögerungskraft [N]  $F_G$  = Gewichtskraft [N]  $m$  = Lastmasse [kg]  $a$  = Verzögerung [m/s<sup>2</sup>]  $g$  = Erdbeschleunigung 9,81 [m/s<sup>2</sup>]  $V$  = Geschwindigkeit H = Stoßdämpfers Hublänge [mm]

Minimale und maximale bewegte Masse

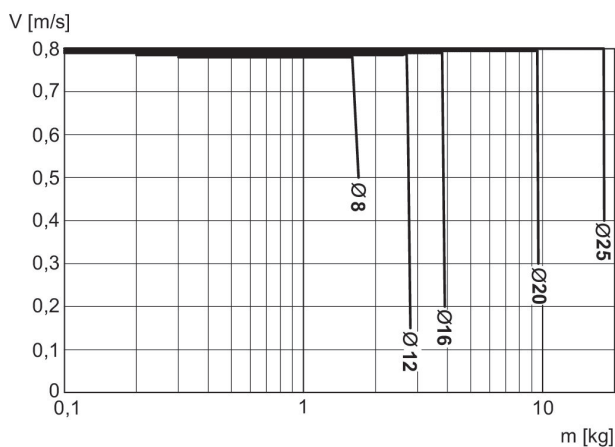

$V$  = Geschwindigkeit [m/s]  
 $m$  = Masse

**Korrekturfaktor erforderliche Geschwindigkeit ein- und ausfahrend, horizontal**

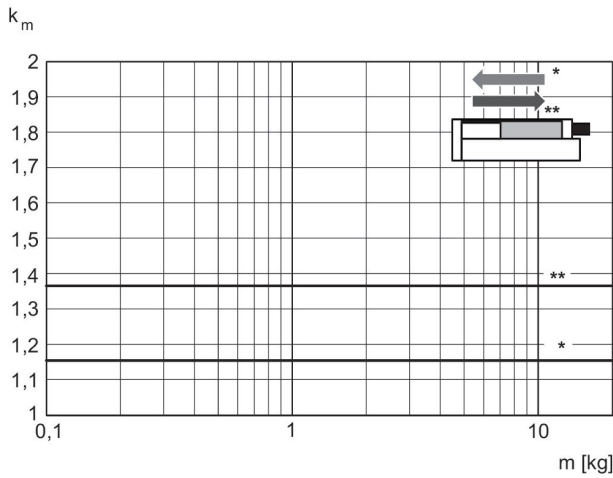

\* einfahrend  
\*\* ausfahrend  
 $V = s/1000 \cdot t \cdot km$   
V = Geschwindigkeit [m/s]  
S = Hub

**Max. zusätzlich bewegte Masse - horizontal**

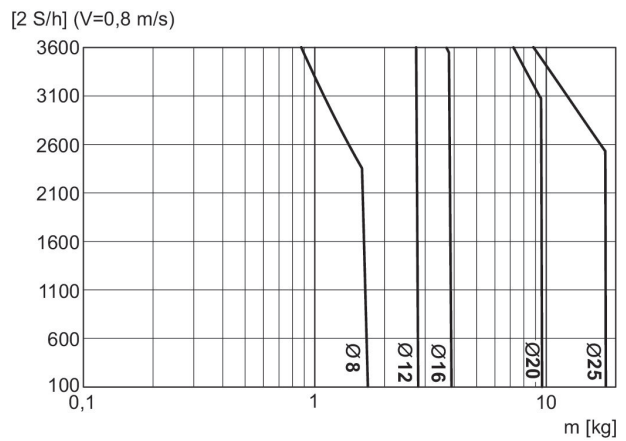

S = Hub [mm]  
2 x S = 1 Zyklus  
V = Geschwindigkeit [m/s]  
m = Masse

**Max. zusätzlich bewegte Masse - vertikal**

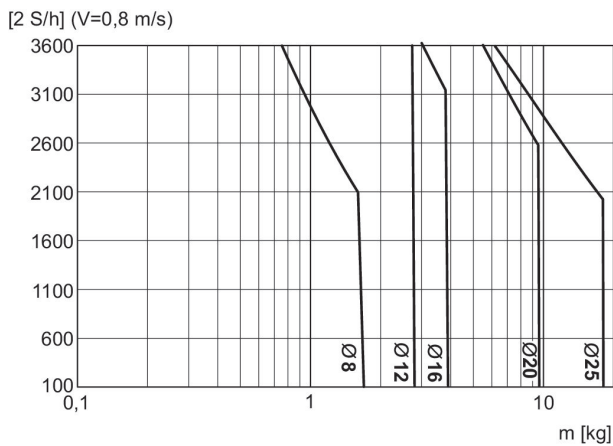

S = Hub [mm]  
2 x S = 1 Zyklus  
V = Geschwindigkeit [m/s]  
m = Masse

**Korrekturfaktor erforderliche Geschwindigkeit ausfahrend, vertikal, nach oben**

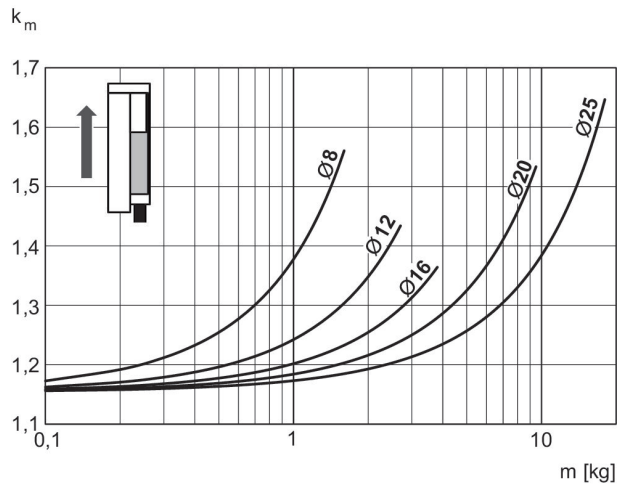

$V = s/1000 \cdot t \cdot km$   
V = Geschwindigkeit [m/s]  
S = Hub [mm]  
t = Zeit [s] für einen Hub  
m = Masse

**Korrekturfaktor erforderliche Geschwindigkeit einfahrend, vertikal, nach oben**

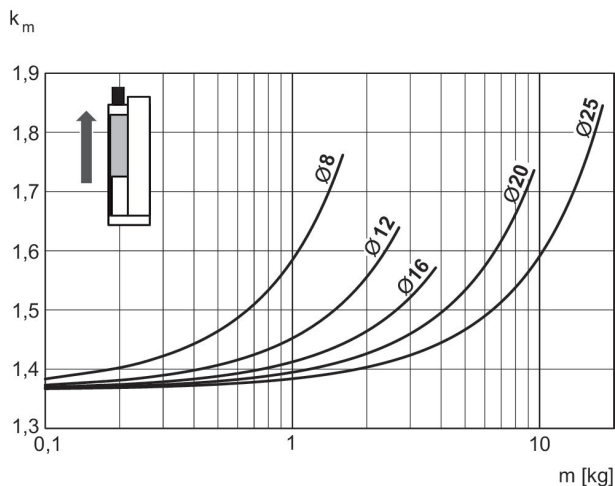

$V = s/1000 \cdot t \cdot km$   
 V = Geschwindigkeit [m/s]  
 S = Hub [mm]  
 t = Zeit [s] für einen Hub  
 m = Masse

**Korrekturfaktor erforderliche Geschwindigkeit einfahrend, vertikal, nach unten**

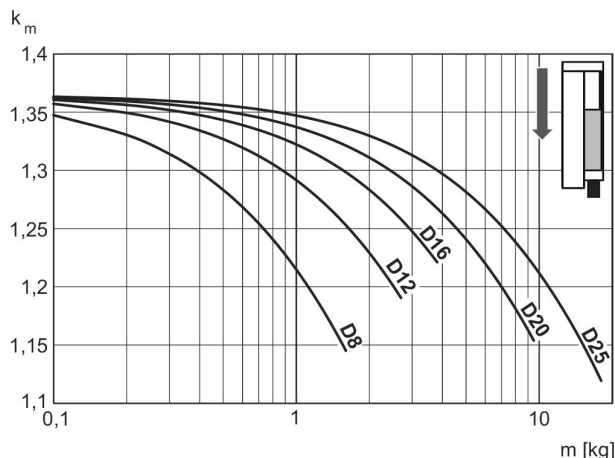

$V = s/1000 \cdot t \cdot km$   
 V = Geschwindigkeit [m/s]  
 S = Hub [mm]  
 t = Zeit [s] für einen Hub  
 m = Masse

**Korrekturfaktor erforderliche Geschwindigkeit ausfahrend, vertikal, nach unten**

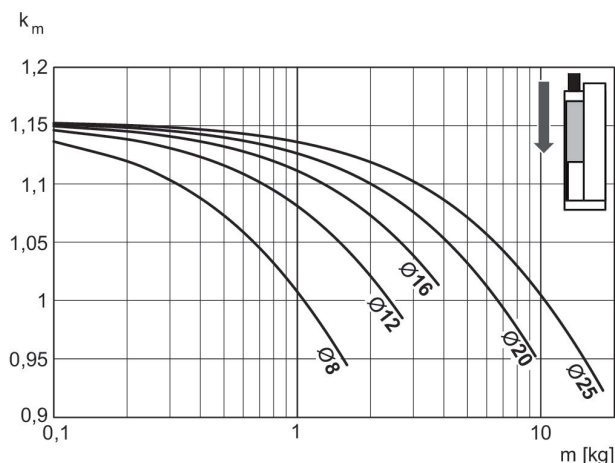

$V = s/1000 \cdot t \cdot km$   
 V = Geschwindigkeit [m/s]  
 S = Hub [mm]  
 t = Zeit [s] für einen Hub  
 m = Masse

**Faktor erreichbare Geschwindigkeit**

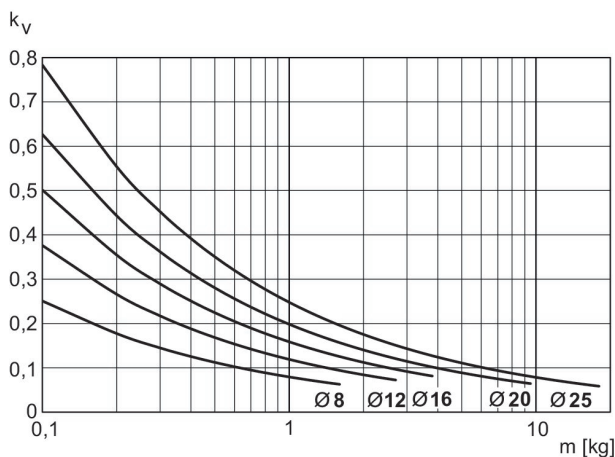

$V = \sqrt{s \cdot kv}$   
 V = Geschwindigkeit [m/s]  
 S = Hub [mm]  
 m = Masse

## Zentrierringe



Außen-Ø [mm]	Lieferumfang [Stück]	Werkstoff	Materialnummer
5,5	6	Nichtrostender Stahl	R412000669
7	6	Nichtrostender Stahl	R412000668
9	6	Nichtrostender Stahl	R412000670
12	6	Nichtrostender Stahl	R412000671
16	6	Nichtrostender Stahl	R402003731

Abmessungen

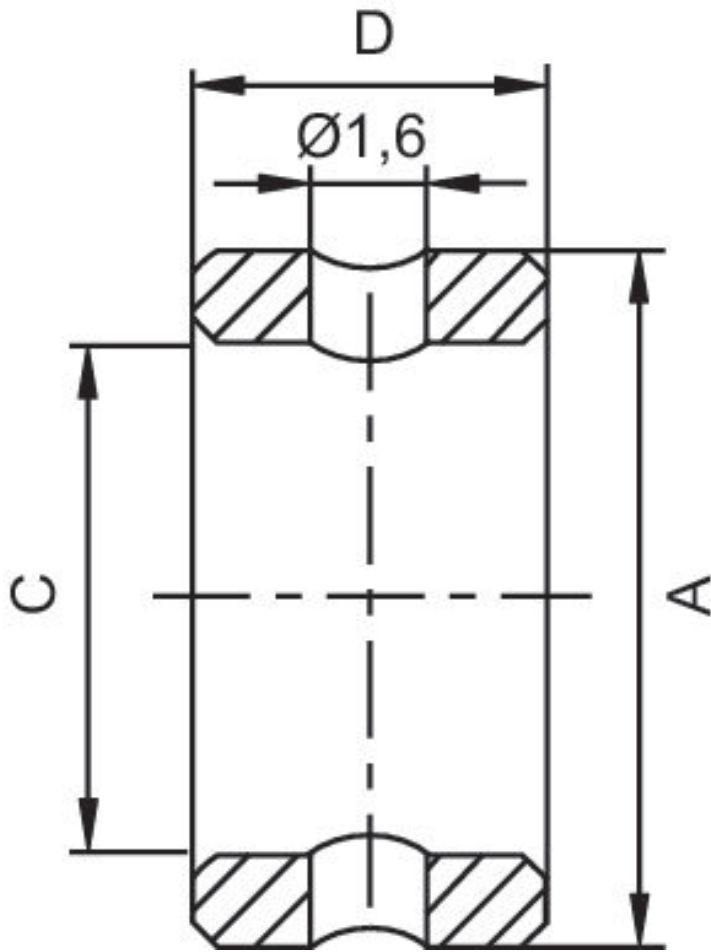

Materialnummer	Ø	A k6	B k6	C ±0,1	D -0,2	E +0,2
R412000669	5	5	-	3,4	3	-
R412000668	7	7	-	5,5	3	-
R412000670	9	9	-	6,6	4	-
R412000671	12	12	-	9,0	4	-
R402003731	16	16	-	11	6	-

## Zentrierringe



Außen-Ø [mm]	Lieferumfang [Stück]	Werkstoff	Materialnummer
7,5	6	Nichtrostender Stahl	R412004030
9,5	6	Nichtrostender Stahl	R412004032
9,7	6	Nichtrostender Stahl	R412004033
12,9	6	Nichtrostender Stahl	R412004034
16,12	6	Nichtrostender Stahl	R402003736

Abmessungen

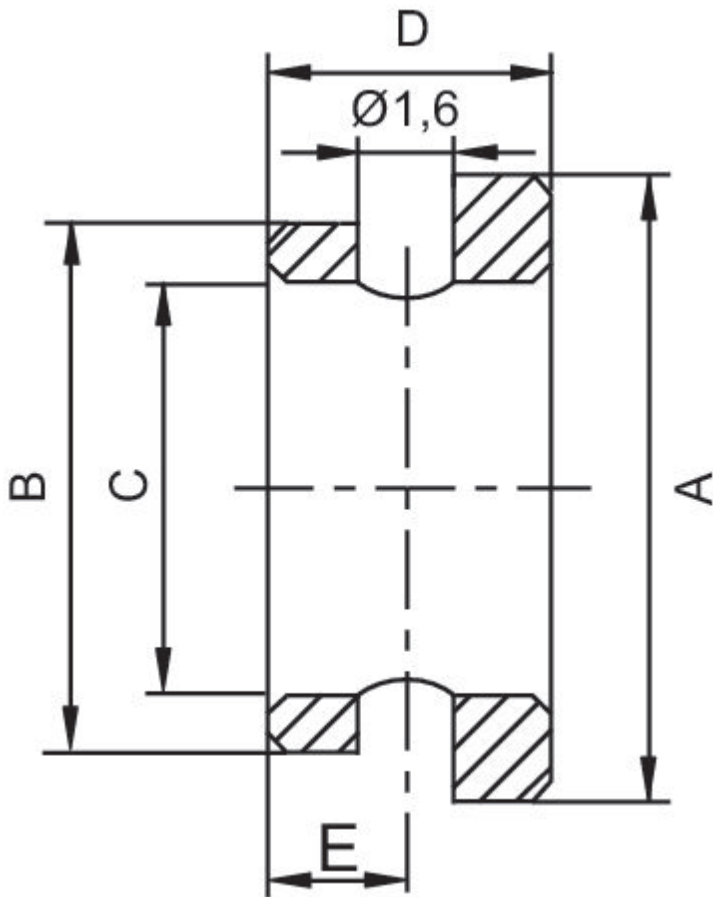

Materialnummer	Ø	A k6	B k6	C ±0,1	D -0,2	E +0,2
R412004030	5-7	7	5	3,4	3	1,5
R412004032	5-9	9	5	3,4	3,5	1,5
R412004033	7-9	9	7	5,5	3,5	1,5
R412004034	9-12	12	9	6,6	4,0	2
R402003736	12-16	16	12	9	5	2

## Spannstücke für kolbenstangenlose Zylinder Serie CKP

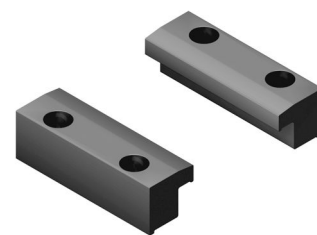

Werkstoff	Materialnummer
Aluminium	R037531000
Aluminium	R037531032
Aluminium	R037531033
Aluminium	R037531026
Aluminium	R037541026
Aluminium	R037551000
Aluminium	R037551033
Aluminium	R037551034

Spannstücke

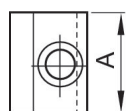
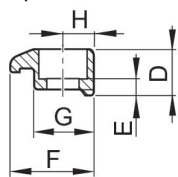

Typ 1

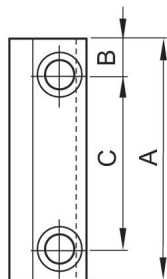

Typ 2

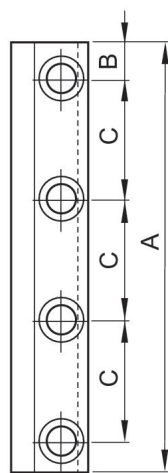

Typ 3

Materialnummer	1)	Typ	A	B	C	D	E	F	G
R037531000	M4	1	25	–	–	9	4.6	14.5	10.5
R037531002	M4	3	87	6	25	9	4.6	14.5	10.5
R037531003	M4	3	107	8.5	30	9	4.6	14.5	10.5
R037531032	M4	2	72	11	50	9	4.6	14.5	10.5
R037531033	M4	2	62	11	40	9	4.6	14.5	10.5
R037531026	M4	3	77	8.5	20	9	4.6	14.5	10.5
R037541002	M5	3	107	8.5	30	11.5	4.8	19.3	14
R037541026	M5	3	77	8.5	20	11.5	4.8	19.3	14
R037551000	M6	1	25	–	–	11.5	5.3	19.3	14
R037551002	M6	3	142	11	40	11.5	5.3	19.3	14
R037551033	M6	2	72	11	50	11.5	5.3	19.3	14
R037551034	M6	2	62	11	40	11.5	5.3	19.3	14
R037551023	M6	2	47	8.5	30	11.5	5.3	19.3	14

Materialnummer	H
R037531000	5
R037531002	5
R037531003	5
R037531032	5
R037531033	5
R037531026	5
R037541002	7
R037541026	7
R037551000	7
R037551002	7
R037551033	7
R037551034	7
R037551023	7

1) Senkung für Schraube

**Drosselrückschlagventil, Serie CC04**

: 2 > 1

Bauart: Abluftdrosselung

Typ Druckluftanschluss 1: Steckanschluss

Umgebungstemperatur min./max.: -10 °C ... 60 °C

Betriebsdruck min./max.: 0.5 bar ... 10 bar

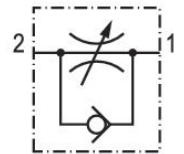

Druckluftanschluss 1	Typ Druckluftanschluss 1	Druckluftanschluss 2	Typ Druckluftanschluss 2	Drosselbohrung [mm]	Nenndurchfluss Qn 2 zu 1 [l/min]	Materialnummer
Ø 4	Steckanschluss	M5	Außengewinde	2	70	R412010564
Ø 6	Steckanschluss	M5	Außengewinde	2	110	R412010565
Ø 4	Steckanschluss	G 1/8	Außengewinde	3.5	150	R412010568
Ø 6	Steckanschluss	G 1/8	Außengewinde	3.5	390	R412010569
Ø 8	Steckanschluss	G 1/8	Außengewinde	3.5	470	R412010570

Abmessungen

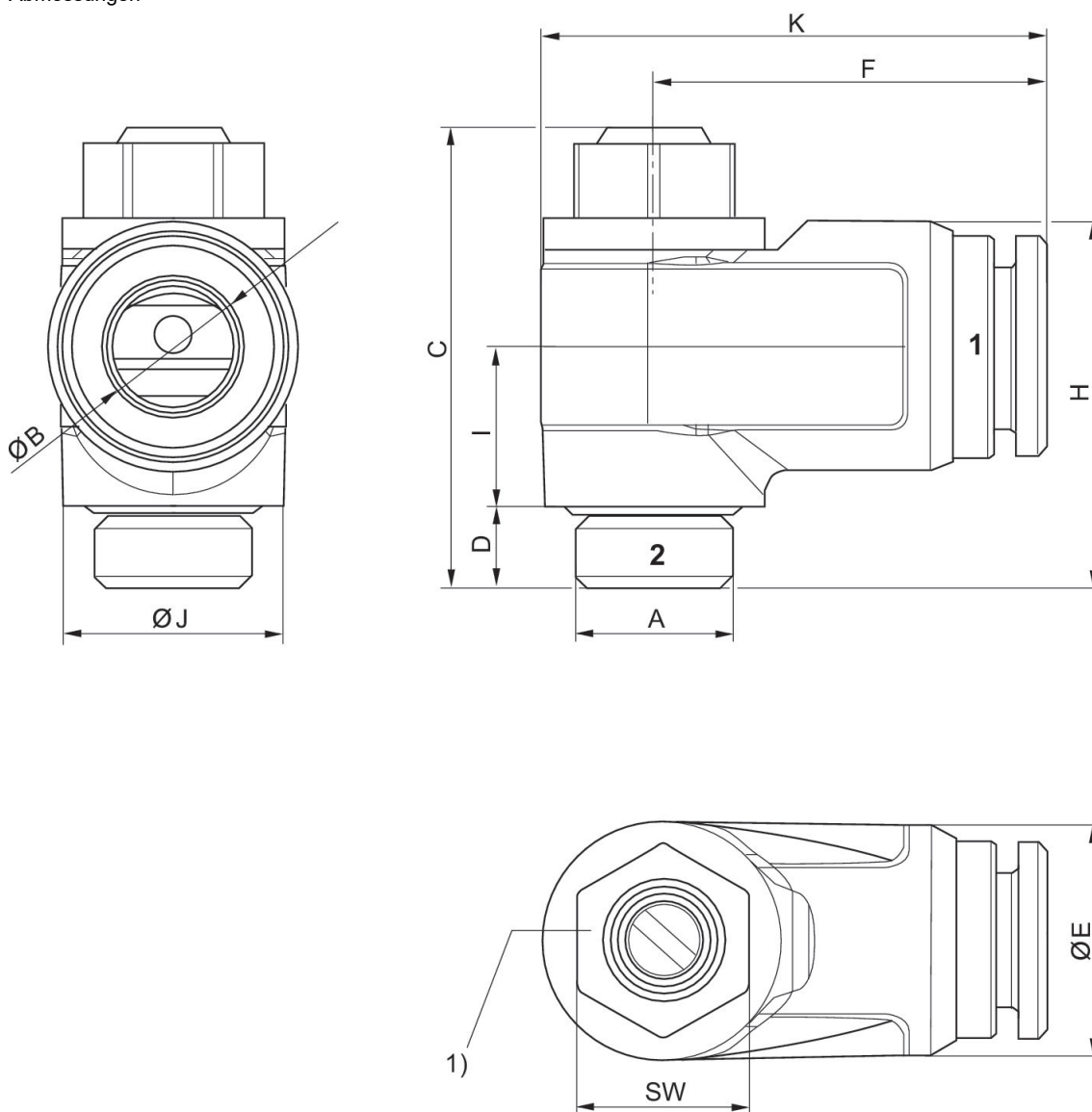

1) Empfohlenes Anzugsmoment  $M_A$ : M 5: 1,1 Nm -0,2 G 1/8: 3,0 Nm -0,3 G 1/4: 6,0 Nm -0,6 G 3/8: 8,0 Nm -1,0 G 1/2: 10,0 Nm -1,0

Materialnummer	Anschluss 1	Anschluss 2	Ø B	C	D	Ø E	F	K	H
R412010564	Ø 4	M5	4	21.8	4	9	15.9	20.4	12
R412010565	Ø 4	G 1/8	6	21.8	4	11.1	17.2	21.8	13
R412010568	Ø 6	M5	4	28.5	5.5	11.5	21.9	28.8	21
R412010569	Ø 6	G 1/8	6	28.5	5.5	13.5	22.4	29.3	21.7
R412010570	Ø 6	G 1/4	8	28.5	5.5	15.5	24.2	31.1	22.7
R412010571	Ø 8	G 1/8	6	33.6	6.5	13	24.3	33.5	25.3
R412010572	Ø 8	G 1/4	8	33.6	6.5	15.5	26.6	35.5	25.3
R412010573	Ø 8	G 1/4	10	33.6	6.5	18.1	29.2	38.1	26.7
R412010574	Ø 10	G 3/8	8	40.8	7	15.6	28.2	40.6	23.6
R412010575	Ø 10	G 3/8	10	40.8	7	19	32	43.3	33.5
R412010576	Ø 10	G 3/8	12	40.8	7	22.1	34.2	45.4	35.6
R412010577	Ø 12	G 1/2	10	47.8	8.3	19.2	34	47.7	41.1
R412010578	Ø 12	G 1/2	12	47.8	8.3	22	36.1	49.8	43.9

Materialnummer	l	Ø J	SW
R412010564	7.5	8.7	7
R412010565	7.5	8.7	7
R412010568	9.8	13.6	10
R412010569	9.8	13.6	10
R412010570	9.8	13.6	10
R412010571	12.8	17.6	13
R412010572	11.5	17.6	13
R412010573	11.5	17.6	13
R412010574	15.8	22.2	16
R412010575	16.4	22.2	16
R412010576	17.8	22.2	16
R412010577	20.3	26.6	18
R412010578	21.5	26.6	18

Durchflussdiagramm

M5

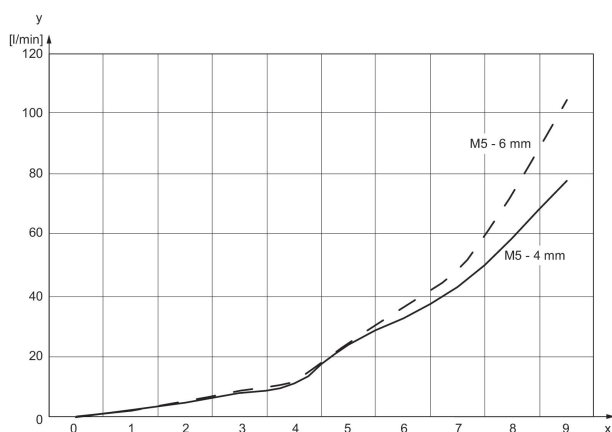

x = Umdrehungen der Drosselschraube y = Durchfluss Qn

Durchflussdiagramm

G 1/8

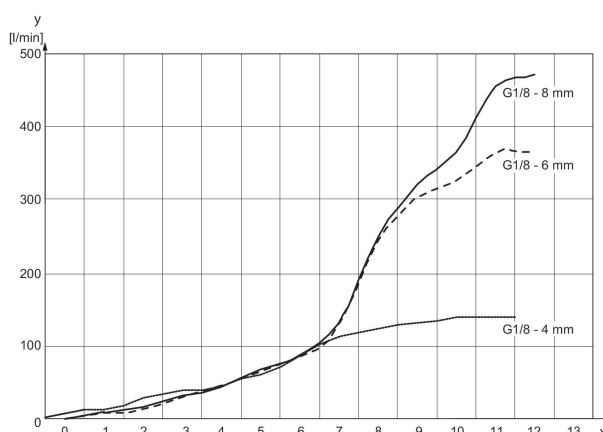

x = Umdrehungen der Drosselschraube y = Durchfluss Qn

Hubeinstellungszubehör



Bauart	Materialnummer
MSC-08-HM	R422100795
MSC-12-HM	R422100797
MSC-20-HM	R422100799
MSC-25-HM	R422100801
MSC-08-EE	R422100796
MSC-12-EE	R422100798
MSC-20-EE	R422100800
MSC-25-EE	R422100802
MSC-08-EM	R412021913
MSC-12-EM	R412021914
MSC-20-EM	R412021915
MSC-25-EM	R412021916
MSC-08	R412021836
MSC-08	7472D00616
MSC-08	7472D00626
MSC-12 / 16	R412022650
MSC-12 / 16	7472D00620
MSC-12 / 16	7472D00619
MSC-20 / 25	7472D00623
MSC-20 / 25	7472D00622
MSC-20 / 25	7472D00625

Abmessungen

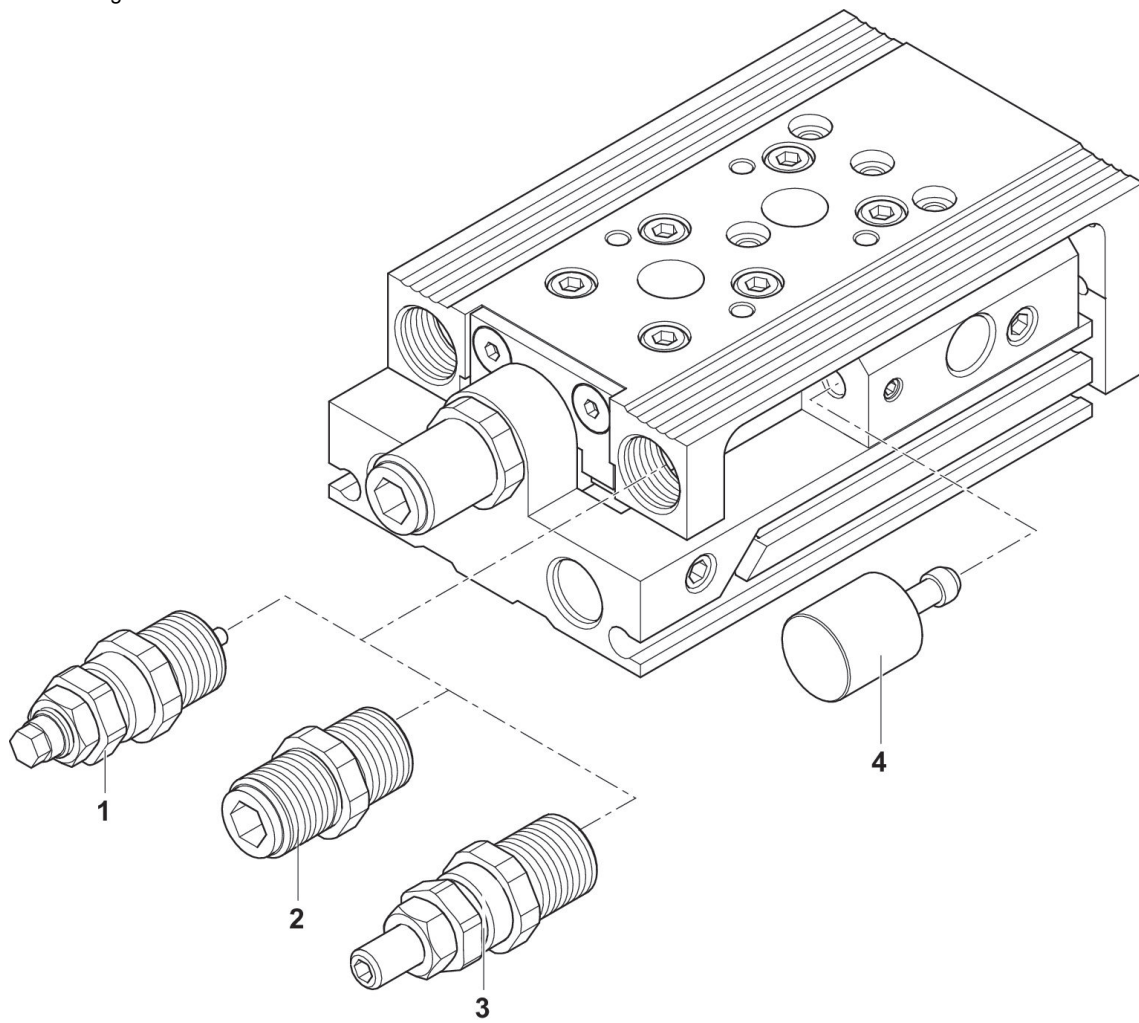

Materialnummer	Typ	Einzelteile	Hub	Zusätzliche Hubbegren- zung in mm	Ø8	Ø12	Ø16	Ø20	Ø25
R422100795	MSC-08-HM	1)	–	–	–	MSC-HM	–	–	–
R422100796	MSC-08-EE	2)	–	–	–	MSC-EE	–	–	–
R422100797	MSC-12-HM	1)	–	–	–	–	MSC-HM	MSC-HM	–
R422100798	MSC-12-EE	2)	–	–	–	–	MSC-EE	MSC-EE	–
R422100799	MSC-20-HM	1)	–	–	–	–	–	–	MSC-HM
R422100800	MSC-20-EE	2)	–	–	–	–	–	–	MSC-EE
R422100801	MSC-25-HM	1)	–	–	–	–	–	–	MSC-HM
R422100802	MSC-25-EE	2)	–	–	–	–	–	–	MSC-EE
R412021913	MSC-08-EM	3)	–	–	MSC-EM	–	–	–	–
R412021914	MSC-12-EM	3)	–	–	–	MSC-EM	MSC-EM	–	–
R412021915	MSC-20-EM	3)	–	–	–	–	–	MSC-EM	–
R412021916	MSC-25-EM	3)	–	–	–	–	–	–	MSC-EM
7472D00616	MSC-08	4)	30-80	10	–	–	–	–	–
7472D00626	MSC-08	4)	30-80	20	–	–	–	–	–
R412021836	MSC-08	4)	40-80	30	–	–	–	–	–
7472D00620	MSC-12 / 16	4)	30-100 / 30-150	10	–	–	–	–	–
7472D00619	MSC-12 / 16	4)	30-100 / 30-150	20	–	–	–	–	–
R412022650	MSC-12 / 16	4)	30-100 / 30-150	30	–	–	–	–	–
7472D00623	MSC-20 / 25	4)	30-200	10	–	–	–	–	–
7472D00622	MSC-20 / 25	4)	30-200	20	–	–	–	–	–
7472D00625	MSC-20 / 25	4)	40-200	30	–	–	–	–	–

**Industriestoßdämpfer, Serie SA1-MC**

Umgebungstemperatur min./max.: -20 °C ... 80 °C

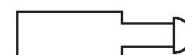

Befestigungsgewinde	Hub [mm]	Energieaufnahme / Hub max. [Nm]	Energieaufnahme / Stunde max. [Nm]	Effektive Masse $m_e$ min. [kg]	Effektive Masse $m_e$ max. [kg]	Rückholkraft min. [N]	Rückholkraft max. [N]	Materialnummer
M6x0,5	5	1	3000	0.8	2.8	2	5	R412010284

Abmessungen

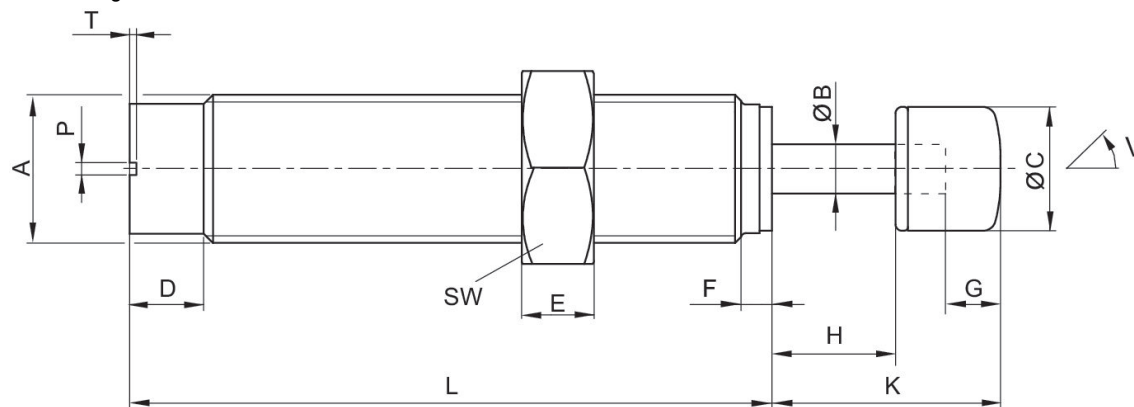

A = Befestigungsgewinde  
V = Neigungswinkel

Materialnummer	Typ	Befestigungsgewinde	ØB	ØC	D	E	F	G	H
R412010291	SA1-MC	M12x1	4	10	6	4	2.5	4	10
R412010292	SA1-MC	M12x1	4	10	6	4	2.5	4	10
R412010293	SA1-MC	M12x1	4	10	6	4	2.5	4	10

Materialnummer	K	L	P	T	SW	W [°]
R412010291	18.5	52	1	0.6	14	2
R412010292	18.5	52	1	0.6	14	2
R412010293	18.5	52	1	0.6	14	2

**R412010284**

Abmessungen

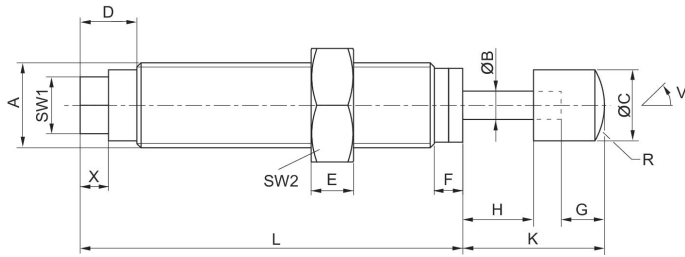

A = Befestigungsgewinde  
V = Neigungswinkel

**Industriestoßdämpfer, Serie SA1-MC**

Umgebungstemperatur min./max.: -20 °C ... 80 °C



Befestigungs-gewinde	Hub [mm]	Energieauf-nahme / Hub max. [Nm]	Energieauf-nahme / St-unde max. [Nm]	Effekti-ve Masse m <sub>e</sub> min. [kg]	Effekti-ve Masse m <sub>e</sub> max. [kg]	Rückholfe-derkraft min. [N]	Rückhol-feder-kraft max. [N]	Materialnummer
M14x1,5	14	30	50000	9.9	76	13	23	R412010305

Abmessungen

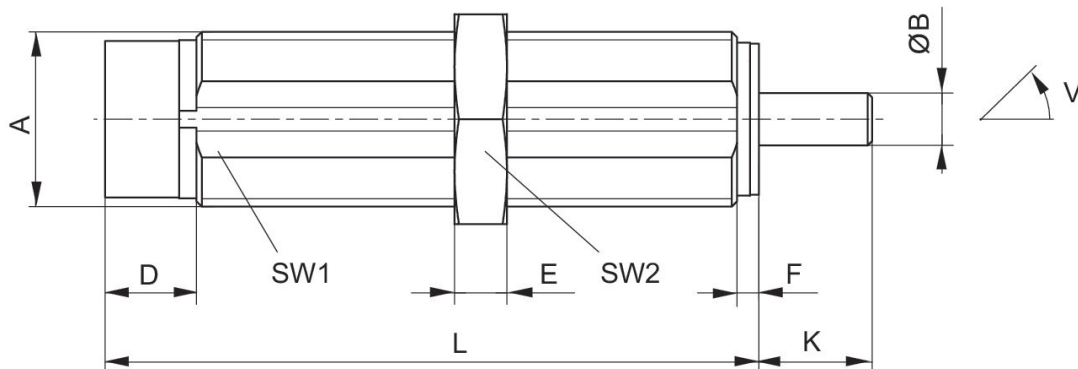

A = Befestigungsgewinde  
V = Neigungswinkel

Materialnummer	Typ	Befestigungsgewinde	ØB	D	E	F	K	L	SW1
R412010307	SA1-MC	M20x1,5	6	10.5	6	2.5	13	75	18
R412010308	SA1-MC	M20x1,5	6	10.5	6	2.5	13	75	18
R412010309	SA1-MC	M20x1,5	6	10.5	6	2.5	13	75	18
R412010310	SA1-MC	M25x1,5	8	9.5	8	3.5	25	108	23
R412010311	SA1-MC	M25x1,5	8	9.5	8	3.5	25	108	23
R412010312	SA1-MC	M25x1,5	8	9.5	8	3.5	25	108	23

Materialnummer	SW2	W [°]
R412010307	24	4
R412010308	24	4
R412010309	24	4
R412010310	30	2
R412010311	30	2
R412010312	30	2

R412010305

Abmessungen

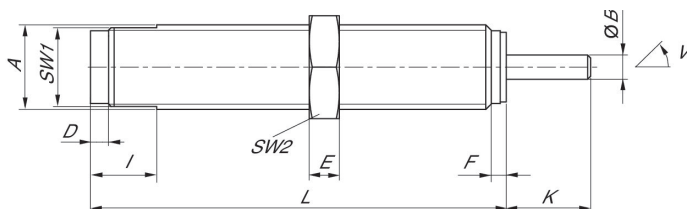

A = Befestigungsgewinde  
V = Neigungswinkel

**Industriestoßdämpfer, Serie SA2-RC für Minischlitten, Serie MSC**

Umgebungstemperatur min./max.: -20 °C ... 80 °C

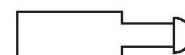

Befestigungs-gewinde	Hub [mm]	Energieauf-nahme / Hub max. [Nm]	Energieauf-nahme / St-unde max. [Nm]	Effekti-ve Masse m <sub>e</sub> min. [kg]	Effekti-ve Masse m <sub>e</sub> max. [kg]	Rückholfe-derkraft min. [N]	Rückhol-feder-kraft max. [N]	Materialnummer
M8x1	7	3	14100	1.7	50	2.5	6	R412010370
M12x1	10	8	26000	5	57	3.5	7	R412010371

Abmessungen

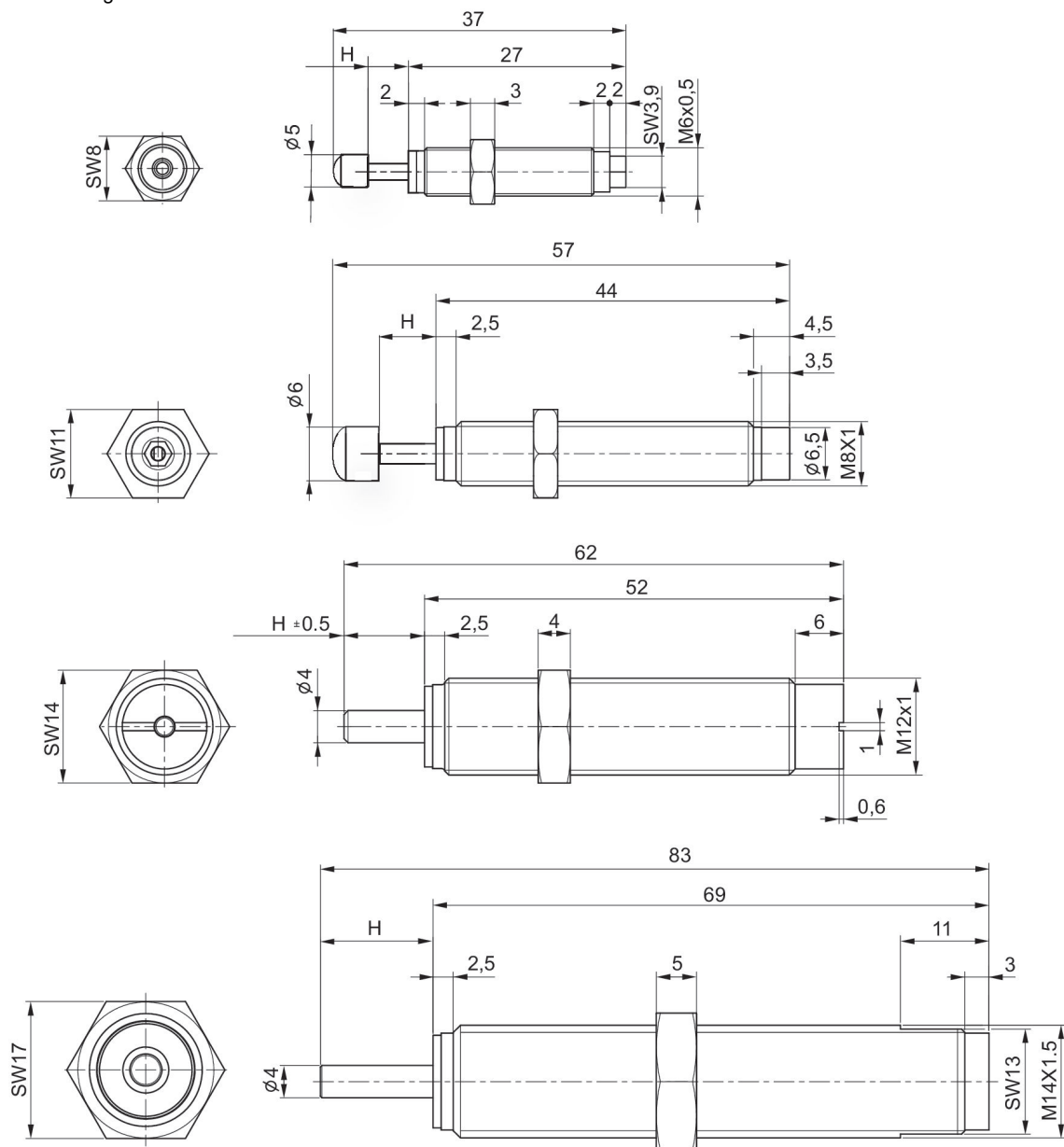

H = Hub

### Endlagenverriegelung, Serie LU

Umgebungstemperatur min./max.: 0 °C ... 60 °C  
Mediumtemperatur min./max.: 0 °C ... 60 °C



Abmessungen

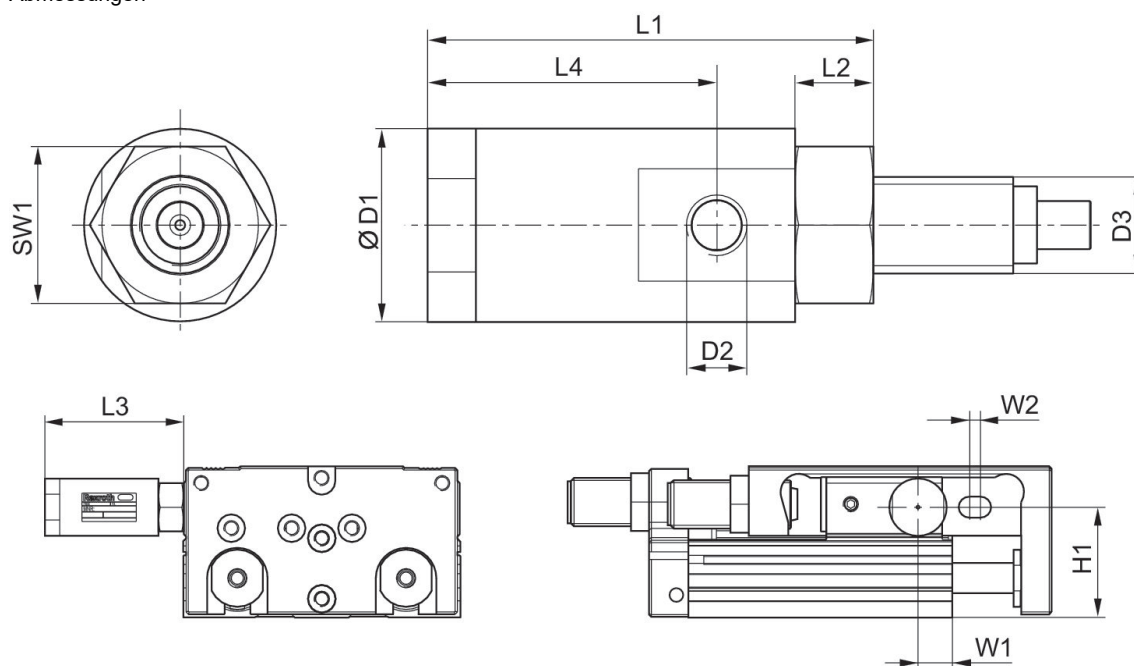

Materialnummer	MSC Ø	Ø D1	D2	D3	H1	L1	L2	L3	L4
R402006023	8 / 12 / 16	16	M5	M8x1	19,5 / 23 / 28,2	37	6.5	38,3 / 35,3 / 34,5	24
R402006027	20 / 25	19	M5	M10x1	36,5 / 42,5	46.2	8.4	42.8	30.3

Materialnummer	SW1	W1	W2
R402006023	13	19,3 / 10 / 10	5
R402006027	16	11,5 / 14,8	3,5 / 5

Hubeinstellungsbereich beim Rückhub bis max. [[5] mm]

### Sensoren, Serie ST4

Direktmontage für Serie: PRA, SSI, GSU, RTC, CKP, GPC, MSC, MSN, RCM, CVI

Indirekte Montage für Serie: MNI, CSL-RD, ICM

Elektrischer Anschluss 2, Typ: offene Kabelenden

Zertifikate: UL (Underwriters Laboratories), cULus, RoHS

Umgebungstemperatur min./max.: -30 °C ... 80 °C



	Kontaktart	Kabellänge L [m]	Schaltstrom DC, max. [A]	Schaltstrom AC, max. [A]	Betriebsspannung DC, min. [V DC]	Betriebsspannung DC, max. [V DC]	Ausführung	Materialnummer
	Reed	3	0.13	0.13	5	30	verpolungssicher	R412019488
	Reed	5	0.13	0.13	5	30	verpolungssicher	R412019489
	elektronisch PNP	3	0.1		10	30	kurzschlussfest, verpolungssicher	R412019680
	elektronisch PNP	5	0.1		10	30	kurzschlussfest, verpolungssicher	R412019681
	NPN	3	0.1		10	30	kurzschlussfest, verpolungssicher	R412019684
	NPN	5	0.1		10	30	kurzschlussfest, verpolungssicher	R412019685

Abmessungen

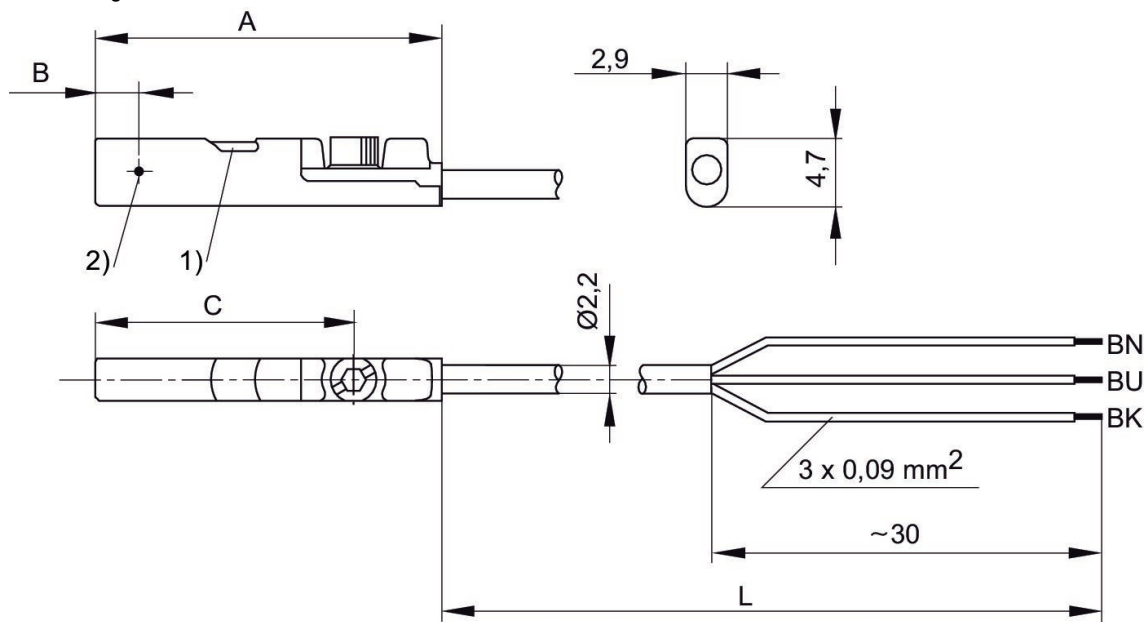

1) LED 2) Schaltpunkt  
L = Kabellänge BN = braun, BK = schwarz, BU = blau

Materialnummer	A	B	C
R412019488	26.3	6.3	20.3
R412019489	26.3	6.3	20.3
R412019680	23.7	2.8	17.7
R412019681	23.7	2.8	17.7
R412019684	23.7	2.8	17.7
R412019685	23.7	2.8	17.7

### Sensoren, Serie ST4

Direktmontage für Serie: PRA, SSI, GSU, RTC, CKP, GPC, MSC, MSN, RCM, CVI

Indirekte Montage für Serie: MNI, CSL-RD, ICM

Elektrischer Anschluss 2, Typ: Stecker

Zertifikate: UL (Underwriters Laboratories), cULus, RoHS

Elektrischer Anschluss 2, Anzahl Pole: 3-polig

Umgebungstemperatur min./max.: -30 °C ... 80 °C



	Kontaktart	Kabellänge L [m]	Schaltstrom DC, max. [A]	Schaltstrom AC, max. [A]	Betriebsspannung DC, min. [V DC]	Betriebsspannung DC, max. [V DC]	Ausführung	Materialnummer
	Reed	0.3	0.13	0.13	5	30	verpolungssicher	R412019490
	Reed	0.5	0.13	0.13	5	30	verpolungssicher	R412019686
	elektronisch PNP	0.3	0.1		10	30	kurzschlussfest, verpolungssicher	R412019493
	elektronisch PNP	0.5	0.1		10	30	kurzschlussfest, verpolungssicher	R412019687

Abmessungen

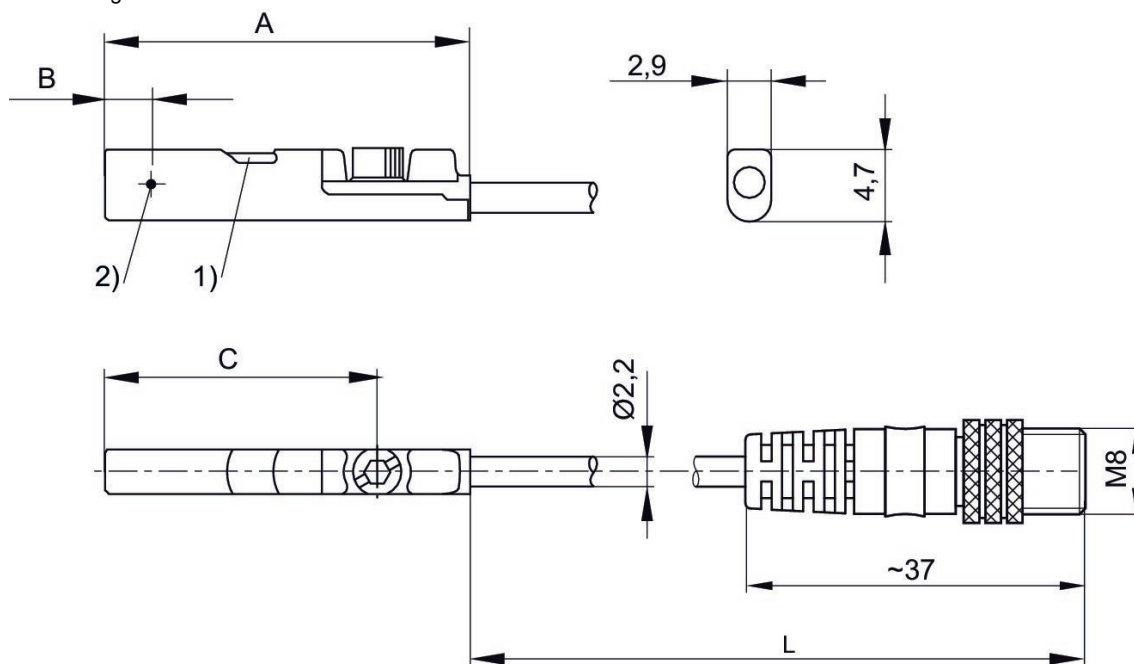

1) LED 2) Schaltpunkt  
L = Kabellänge

Materialnummer	A	B	C
R412019490	26.3	6.3	20.3
R412019686	26.3	6.3	20.3
R412019493	23.7	2.8	17.7
R412019687	23.7	2.8	17.7

**R412019490, R412019686, R412019493, R412019687**

Pin-Belegung M8x1 (3-polig)

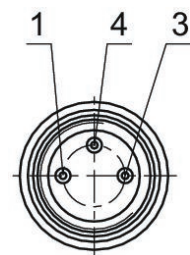

Pin	Belegung
1	(+)
3	(-)
4	(OUT)

### Sensoren, Serie ST4

Direktmontage für Serie: PRA, SSI, GSU, RTC, CKP, GPC, MSC, MSN, RCM, CVI

Indirekte Montage für Serie: MNI, CSL-RD, ICM

Elektrischer Anschluss 2, Typ: Stecker

Zertifikate: UL (Underwriters Laboratories), cULus, RoHS

Elektrischer Anschluss 2, Anzahl Pole: 3-polig

Umgebungstemperatur min./max.: -30 °C ... 80 °C



	Kontaktart	Kabellänge L [m]	Schaltstrom DC, max. [A]	Schaltstrom AC, max. [A]	Betriebsspannung DC, min. [V DC]	Betriebsspannung DC, max. [V DC]	Ausführung	Materialnummer
	Reed	0.3	0.13	0.13	5	30	verpolungssicher	R412019688
	elektronisch PNP	0.3	0.1		10	30	kurzschlussfest, verpolungssicher	R412019689

#### Abmessungen

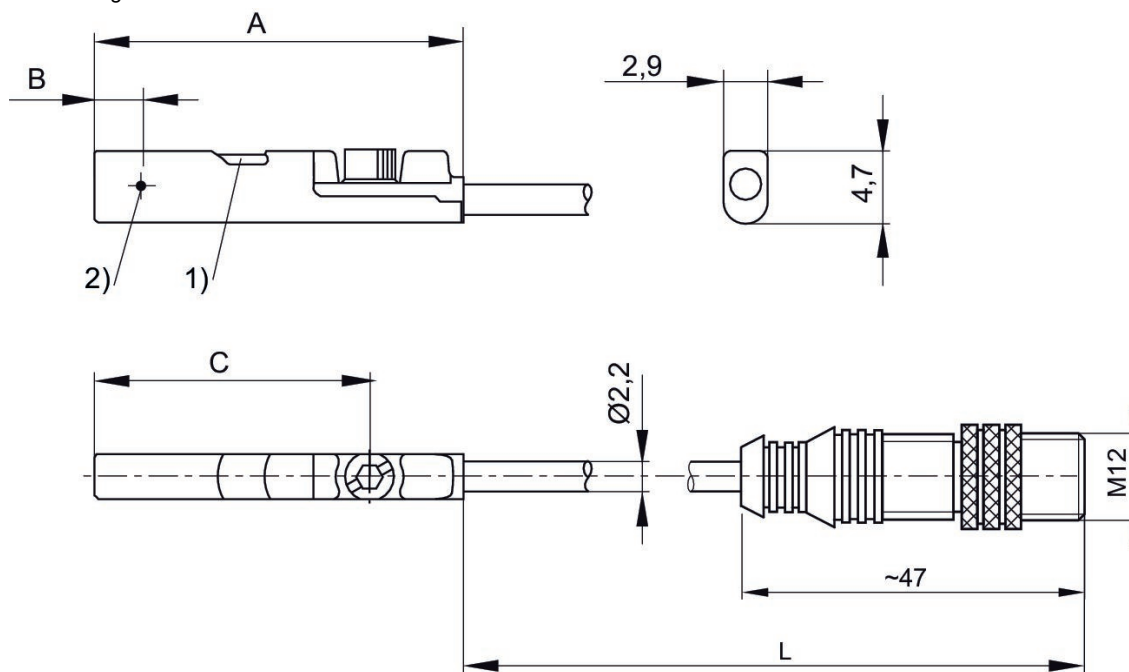

1) LED 2) Schaltpunkt  
L = Kabellänge

Materialnummer	A	B	C
R412019688	26.3	6.3	20.3
R412019689	23.7	2.8	17.7

R412019688, R412019689

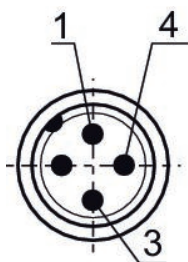

Pin	Belegung
1	(+)
3	(-)
4	(OUT)

### Sensoren, Serie ST4

Direktmontage für Serie: PRA, SSI, GSU, RTC, CKP, GSP, MSC, MSN, RCM, CVI

Indirekte Montage für Serie: MNI, CSL-RD, ICM

Elektrischer Anschluss 2, Typ: Stecker

Zertifikate: UL (Underwriters Laboratories), cULus, RoHS

Elektrischer Anschluss 2, Anzahl Pole: 3-polig

Umgebungstemperatur min./max.: -30 °C ... 80 °C



	Kontaktart	Kabellänge L [m]	Schaltstrom DC, max. [A]	Schaltstrom AC, max. [A]	Betriebsspannung DC, min. [V DC]	Betriebsspannung DC, max. [V DC]	Ausführung	Materialnummer
	Reed	0.3	0.13	0.13	5	30	verpolungssicher	R412019682
	elektronisch PNP	0.3	0.1		10	30	kurzschlussfest, verpolungssicher	R412019683
	NPN	0.3	0.1		10	30	kurzschlussfest, verpolungssicher	R412019694

Abmessungen

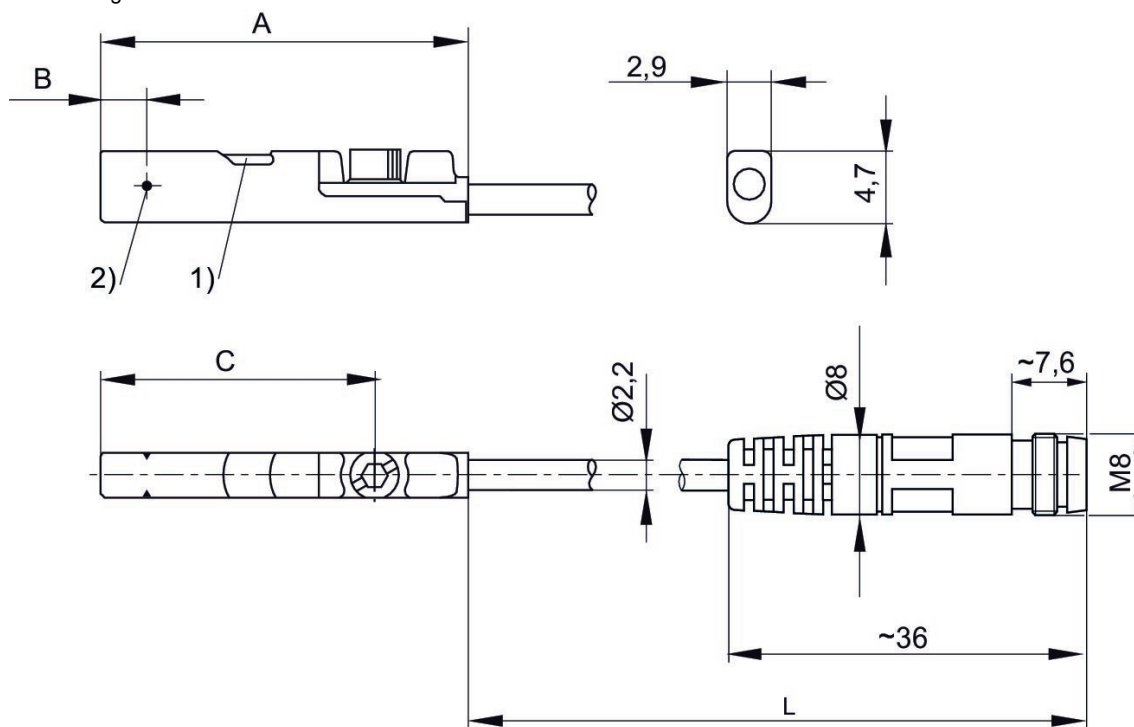

1) LED 2) Schaltpunkt  
L = Kabellänge

Materialnummer	A	B	C
R412019682	26.3	6.3	20.3
R412019683	23.7	2.8	17.7
R412019694	23.7	2.8	17.7

**R412019682, R412019683, R412019694**

Pin-Belegung M8x1 (3-polig)

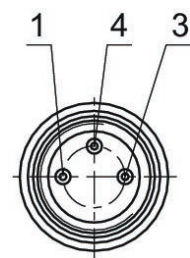

Pin	Belegung
1	(+)
3	(-)
4	(OUT)

### Sensoren, Serie ST4-2P

Direktmontage für Serie: PRA, SSI, RTC, GPC, MSC, MSN, RCM, CVI  
 Indirekte Montage für Serie: MNI, CSL-RD, ICM  
 Elektrischer Anschluss 2, Typ: Stecker  
 Zertifikate: RoHS  
 Elektrischer Anschluss 2, Anzahl Pole: 4-polig  
 Umgebungstemperatur min./max.: -20 °C ... 75 °C

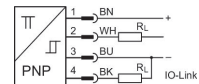

Nutbreite	Kontaktart	Elektrischer Anschluss Größe	Elektrischer Anschluss Anzahl Pole	Materialnummer
4 mm C-Nut	elektronisch PNP	M8x1	4-polig	R412025689

#### Abmessungen

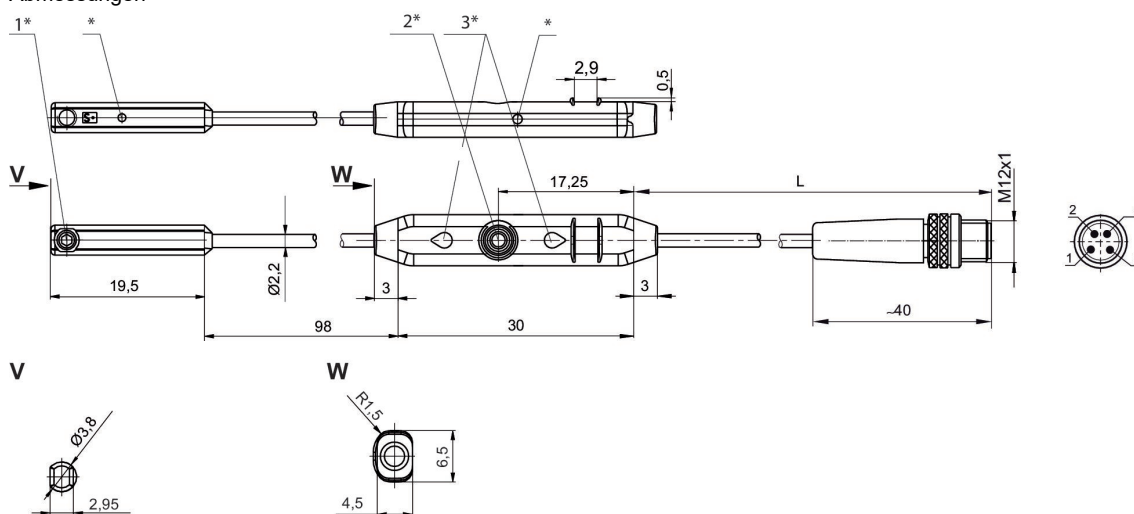

1\* = Befestigungsschraube 2\* = Teach-Taste 3\* = LED  
 L = Kabellänge  
 PIN-Belegung: 1 = (+), 2 = (OUT), 3 = (-), 4 = (OUT) IO-Link  
 \* Schaltpunkt

#### R412025689

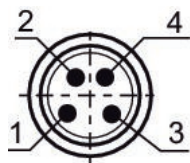





Pin	Belegung
1	(+)
2	(OUT)
3	(-)
4	(OUT) IO-Link



Efficient pneumatic solutions, our program:  
cylinders and drives, valves and valve systems,  
air supply management, proportional pressure  
control valves



Visit us: [www.Emerson.com/aventics](http://www.Emerson.com/aventics)  
Your local contact: [Emerson.com/contactus](http://Emerson.com/contactus)

-  [Emerson.com](http://Emerson.com)
-  [Facebook.com/EmersonAutomationSolutions](https://Facebook.com/EmersonAutomationSolutions)
-  [LinkedIn.com/company/Emerson-Automation-Solutions](https://LinkedIn.com/company/Emerson-Automation-Solutions)
-  [Twitter.com/EMR\\_Automation](https://Twitter.com/EMR_Automation)



The Emerson logo is a trademark and service mark of Emerson Electric Co. AVENTICS is a registered trademark of one of the Emerson family of companies. All other trademarks are the property of their respective owners. © 2020 Emerson Electric Co. All rights reserved.



**CONSIDER IT SOLVED™**