

Series 167



AVENTICS™

**AVENTICS Series 167 Tie-rod
cylinder**

EMERSON™

Series 167

The AVENTICS Series 167 is a tie rod cylinder according ISO 6431 and offers the highest robustness for tough environment.

- Ø 25 ... 100 mm
- Max. stroke: 1500 mm
- For high stroke frequencies and pulley applications
- Plug-in with tube nut / External thread



Overview drawing

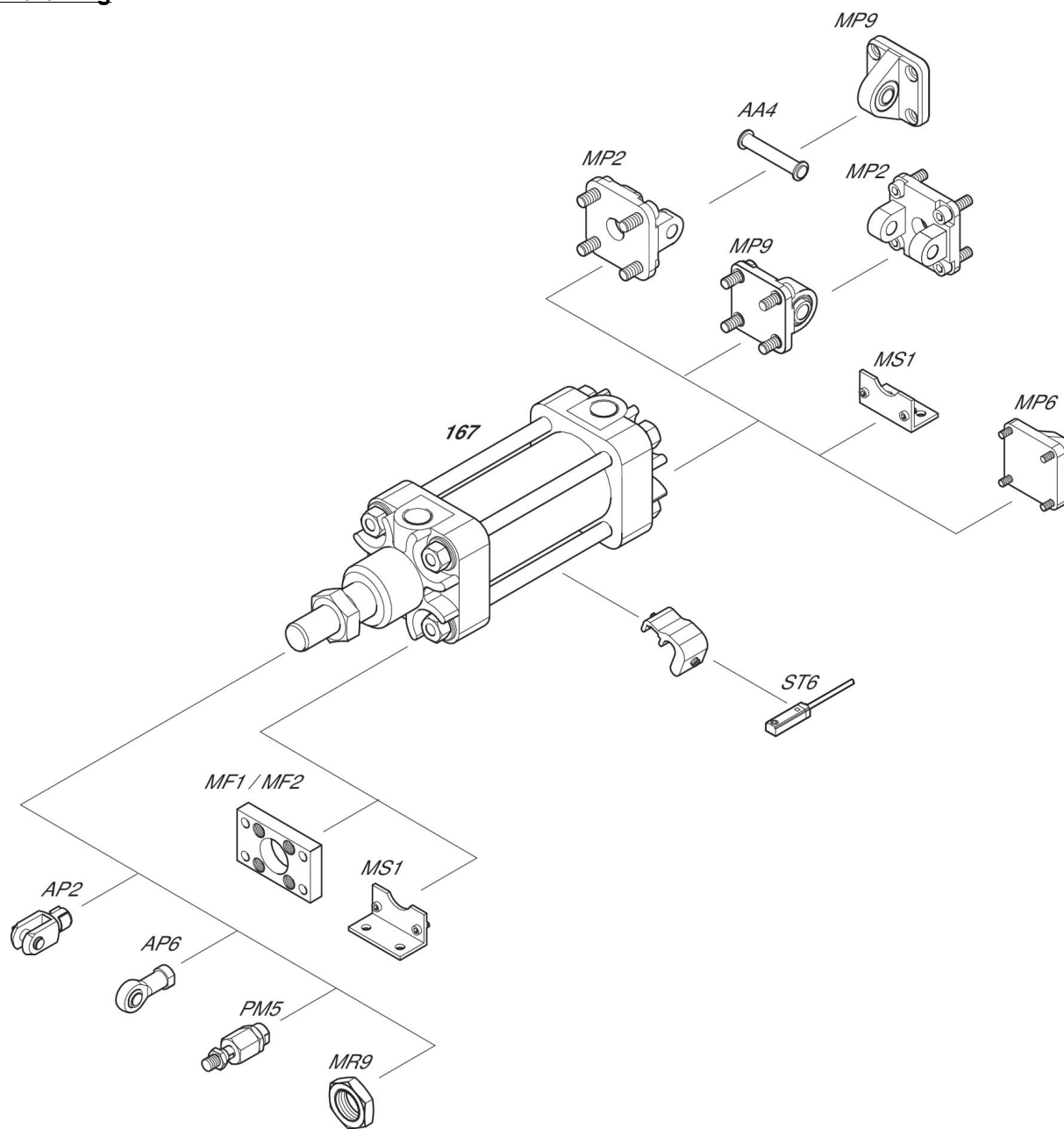

Tie rod cylinder ISO 6431, Series 167

ISO 6431
Profile and tie rod cylinders
Industry standard
single
Piston with magnet
Pneumatic adjustable cushioning
External thread
Internal thread
Double-acting

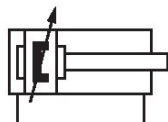

Piston Ø [mm]	Stroke [mm]	Ports	Cushioning	Magnet-ic piston	Piston rod thread	Scraper	Retract-ing piston force [N]	Extract-ing piston force [N]	Part No.
25	25	G 1/8	Pneumatic adjustable cushioning	Piston with magnet	M10x1,25	Standard Industry Scraper	230	300	1670202000
25	50	G 1/8	Pneumatic adjustable cushioning	Piston with magnet	M10x1,25	Standard Industry Scraper	230	300	1670205000
25	80	G 1/8	Pneumatic adjustable cushioning	Piston with magnet	M10x1,25	Standard Industry Scraper	230	300	1670208000
25	100	G 1/8	Pneumatic adjustable cushioning	Piston with magnet	M10x1,25	Standard Industry Scraper	230	300	1670210000
25	125	G 1/8	Pneumatic adjustable cushioning	Piston with magnet	M10x1,25	Standard Industry Scraper	230	300	1670212000
25	160	G 1/8	Pneumatic adjustable cushioning	Piston with magnet	M10x1,25	Standard Industry Scraper	230	300	1670216000
25	200	G 1/8	Pneumatic adjustable cushioning	Piston with magnet	M10x1,25	Standard Industry Scraper	230	300	1670220000
25	250	G 1/8	Pneumatic adjustable cushioning	Piston with magnet	M10x1,25	Standard Industry Scraper	230	300	1670225000
32	25	G 1/8	Pneumatic adjustable cushioning	Piston with magnet	M10x1,25	Standard Industry Scraper	420	480	1670302000
32	50	G 1/8	Pneumatic adjustable cushioning	Piston with magnet	M10x1,25	Standard Industry Scraper	420	480	1670305000
32	80	G 1/8	Pneumatic adjustable cushioning	Piston with magnet	M10x1,25	Standard Industry Scraper	420	480	1670308000
32	100	G 1/8	Pneumatic adjustable cushioning	Piston with magnet	M10x1,25	Standard Industry Scraper	420	480	1670310000
32	125	G 1/8	Pneumatic adjustable cushioning	Piston with magnet	M10x1,25	Standard Industry Scraper	420	480	1670312000

Piston Ø [mm]	Stroke [mm]	Ports	Cushioning	Magnetic piston	Piston rod thread	Scraper	Retracting piston force [N]	Extracting piston force [N]	Part No.
32	160	G 1/8	Pneumatic adjustable cushioning	Piston with magnet	M10x1,25	Standard Industry Scraper	420	480	1670316000
32	200	G 1/8	Pneumatic adjustable cushioning	Piston with magnet	M10x1,25	Standard Industry Scraper	420	480	1670320000
32	250	G 1/8	Pneumatic adjustable cushioning	Piston with magnet	M10x1,25	Standard Industry Scraper	420	480	1670325000
40	25	G 1/4	Pneumatic adjustable cushioning	Piston with magnet	M12x1,25	Standard Industry Scraper	640	760	1670402000
40	50	G 1/4	Pneumatic adjustable cushioning	Piston with magnet	M12x1,25	Standard Industry Scraper	640	760	1670405000
40	80	G 1/4	Pneumatic adjustable cushioning	Piston with magnet	M12x1,25	Standard Industry Scraper	640	760	1670408000
40	100	G 1/4	Pneumatic adjustable cushioning	Piston with magnet	M12x1,25	Standard Industry Scraper	640	760	1670410000
40	125	G 1/4	Pneumatic adjustable cushioning	Piston with magnet	M12x1,25	Standard Industry Scraper	640	760	1670412000
40	160	G 1/4	Pneumatic adjustable cushioning	Piston with magnet	M12x1,25	Standard Industry Scraper	640	760	1670416000
40	200	G 1/4	Pneumatic adjustable cushioning	Piston with magnet	M12x1,25	Standard Industry Scraper	640	760	1670420000
40	250	G 1/4	Pneumatic adjustable cushioning	Piston with magnet	M12x1,25	Standard Industry Scraper	640	760	1670425000
50	25	G 1/4	Pneumatic adjustable cushioning	Piston with magnet	M16x1,5	Standard Industry Scraper	990	1180	1670502000
50	50	G 1/4	Pneumatic adjustable cushioning	Piston with magnet	M16x1,5	Standard Industry Scraper	990	1180	1670505000
50	80	G 1/4	Pneumatic adjustable cushioning	Piston with magnet	M16x1,5	Standard Industry Scraper	990	1180	1670508000
50	100	G 1/4	Pneumatic adjustable cushioning	Piston with magnet	M16x1,5	Standard Industry Scraper	990	1180	1670510000
50	125	G 1/4	Pneumatic adjustable cushioning	Piston with magnet	M16x1,5	Standard Industry Scraper	990	1180	1670512000
50	160	G 1/4	Pneumatic adjustable cushioning	Piston with magnet	M16x1,5	Standard Industry Scraper	990	1180	1670516000
50	200	G 1/4	Pneumatic adjustable cushioning	Piston with magnet	M16x1,5	Standard Industry Scraper	990	1180	1670520000

Piston Ø [mm]	Stroke [mm]	Ports	Cushioning	Magnetic piston	Piston rod thread	Scraper	Retracting piston force [N]	Extracting piston force [N]	Part No.
50	250	G 1/4	Pneumatic adjustable cushioning	Piston with magnet	M16x1,5	Standard Industry Scraper	990	1180	1670525000
50	320	G 1/4	Pneumatic adjustable cushioning	Piston with magnet	M16x1,5	Standard Industry Scraper	990	1180	1670532000
50	400	G 1/4	Pneumatic adjustable cushioning	Piston with magnet	M16x1,5	Standard Industry Scraper	990	1180	1670540000
50	500	G 1/4	Pneumatic adjustable cushioning	Piston with magnet	M16x1,5	Standard Industry Scraper	990	1180	1670550000
63	25	G 3/8	Pneumatic adjustable cushioning	Piston with magnet	M16x1,5	Standard Industry Scraper	1680	1860	1670602000
63	50	G 3/8	Pneumatic adjustable cushioning	Piston with magnet	M16x1,5	Standard Industry Scraper	1680	1860	1670605000
63	80	G 3/8	Pneumatic adjustable cushioning	Piston with magnet	M16x1,5	Standard Industry Scraper	1680	1860	1670608000
63	100	G 3/8	Pneumatic adjustable cushioning	Piston with magnet	M16x1,5	Standard Industry Scraper	1680	1860	1670610000
63	125	G 3/8	Pneumatic adjustable cushioning	Piston with magnet	M16x1,5	Standard Industry Scraper	1680	1860	1670612000
63	160	G 3/8	Pneumatic adjustable cushioning	Piston with magnet	M16x1,5	Standard Industry Scraper	1680	1860	1670616000
63	200	G 3/8	Pneumatic adjustable cushioning	Piston with magnet	M16x1,5	Standard Industry Scraper	1680	1860	1670620000
63	250	G 3/8	Pneumatic adjustable cushioning	Piston with magnet	M16x1,5	Standard Industry Scraper	1680	1860	1670625000
63	320	G 3/8	Pneumatic adjustable cushioning	Piston with magnet	M16x1,5	Standard Industry Scraper	1680	1860	1670632000
63	400	G 3/8	Pneumatic adjustable cushioning	Piston with magnet	M16x1,5	Standard Industry Scraper	1680	1860	1670640000
63	500	G 3/8	Pneumatic adjustable cushioning	Piston with magnet	M16x1,5	Standard Industry Scraper	1680	1860	1670650000
80	25	G 3/8	Pneumatic adjustable cushioning	Piston with magnet	M20x1,5	Standard Industry Scraper	2720	3000	1670802000
80	50	G 3/8	Pneumatic adjustable cushioning	Piston with magnet	M20x1,5	Standard Industry Scraper	2720	3000	1670805000
80	80	G 3/8	Pneumatic adjustable cushioning	Piston with magnet	M20x1,5	Standard Industry Scraper	2720	3000	1670808000

Piston Ø [mm]	Stroke [mm]	Ports	Cushioning	Magnetic piston	Piston rod thread	Scraper	Retracting piston force [N]	Extracting piston force [N]	Part No.
80	100	G 3/8	Pneumatic adjustable cushioning	Piston with magnet	M20x1,5	Standard Industry Scraper	2720	3000	1670810000
80	125	G 3/8	Pneumatic adjustable cushioning	Piston with magnet	M20x1,5	Standard Industry Scraper	2720	3000	1670812000
80	160	G 3/8	Pneumatic adjustable cushioning	Piston with magnet	M20x1,5	Standard Industry Scraper	2720	3000	1670816000
80	200	G 3/8	Pneumatic adjustable cushioning	Piston with magnet	M20x1,5	Standard Industry Scraper	2720	3000	1670820000
80	250	G 3/8	Pneumatic adjustable cushioning	Piston with magnet	M20x1,5	Standard Industry Scraper	2720	3000	1670825000
80	320	G 3/8	Pneumatic adjustable cushioning	Piston with magnet	M20x1,5	Standard Industry Scraper	2720	3000	1670832000
80	400	G 3/8	Pneumatic adjustable cushioning	Piston with magnet	M20x1,5	Standard Industry Scraper	2720	3000	1670840000
80	500	G 3/8	Pneumatic adjustable cushioning	Piston with magnet	M20x1,5	Standard Industry Scraper	2720	3000	1670850000
100	25	G 1/2	Pneumatic adjustable cushioning	Piston with magnet	M20x1,5	Standard Industry Scraper	4230	4680	1671002000
100	50	G 1/2	Pneumatic adjustable cushioning	Piston with magnet	M20x1,5	Standard Industry Scraper	4230	4680	1671005000
100	80	G 1/2	Pneumatic adjustable cushioning	Piston with magnet	M20x1,5	Standard Industry Scraper	4230	4680	1671008000
100	100	G 1/2	Pneumatic adjustable cushioning	Piston with magnet	M20x1,5	Standard Industry Scraper	4230	4680	1671010000
100	125	G 1/2	Pneumatic adjustable cushioning	Piston with magnet	M20x1,5	Standard Industry Scraper	4230	4680	1671012000
100	160	G 1/2	Pneumatic adjustable cushioning	Piston with magnet	M20x1,5	Standard Industry Scraper	4230	4680	1671016000
100	200	G 1/2	Pneumatic adjustable cushioning	Piston with magnet	M20x1,5	Standard Industry Scraper	4230	4680	1671020000
100	250	G 1/2	Pneumatic adjustable cushioning	Piston with magnet	M20x1,5	Standard Industry Scraper	4230	4680	1671025000
100	320	G 1/2	Pneumatic adjustable cushioning	Piston with magnet	M20x1,5	Standard Industry Scraper	4230	4680	1671032000
100	400	G 1/2	Pneumatic adjustable cushioning	Piston with magnet	M20x1,5	Standard Industry Scraper	4230	4680	1671040000

Piston Ø [mm]	Stroke [mm]	Ports	Cushioning	Magnetic piston	Piston rod thread	Scraper	Retracting piston force [N]	Extracting piston force [N]	Part No.
100	500	G 1/2	Pneumatic adjustable cushioning	Piston with magnet	M20x1,5	Standard Industry Scraper	4230	4680	1671050000

Dimensions

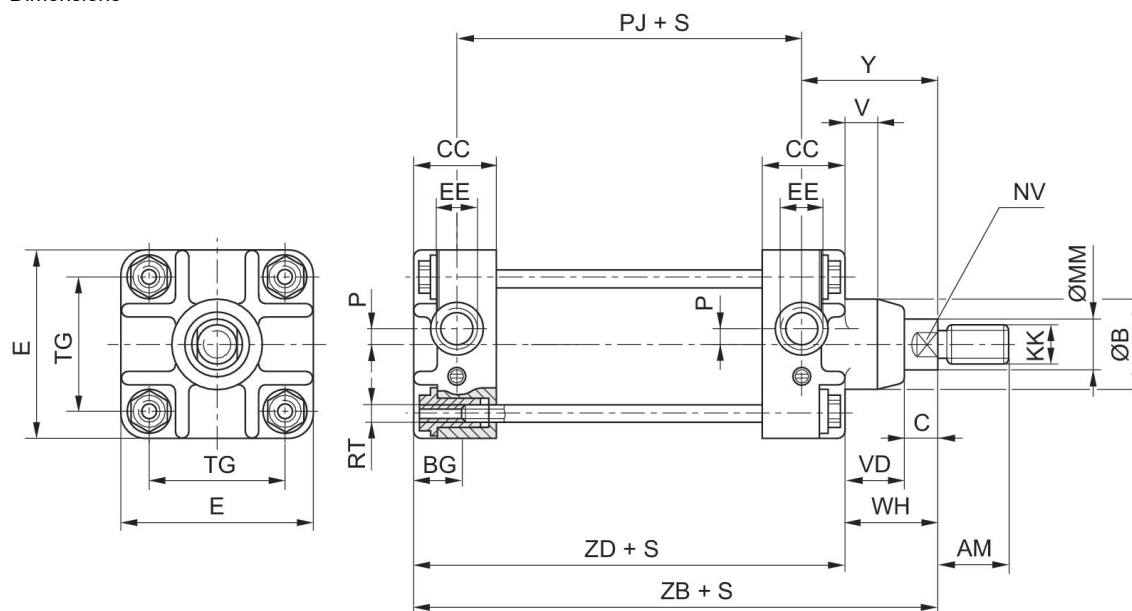

Piston Ø	AM	Ø B h12	BG	C	CC	E	EE	KK	Ø MM	NV
25	22	23	12	8	20,0	40	G 1/8	M10x1,25	12	10
32	22	25	12	10	27,5	47	G 1/8	M10x1,25	12	10
40	24	35	15	13	30,0	56	G 1/4	M12x1,25	16	13
50	32	40	15	15	30,0	63	G 1/4	M16x1,5	20	17
63	32	40	19	14	34,0	81	G 3/8	M16x1,5	20	17
80	40	48	19	16	36,0	95	G 3/8	M20x1,5	25	22
100	40	55	23	16	40,0	115	G 1/2	M20x1,5	25	22

Piston Ø	P	PJ	RT	TG	V	VD	WH	Y	ZB	ZD
25	-	58	M5	27	-	16	24	31	98 ±1,2	74
32	4	65	M5	32	5	16	26	41	120 ±1,2	94
40	4	69	M6	40	5	20	33	48	132 ±1,2	99
50	4	72	M6	46	6	23	38	54	142 ±1,2	104
63	6	79	M8	59	6	27	41	58	154 ±1,4	113
80	9	86	M8	73	8	32	48	67	172 ±1,4	124
100	12	100	M10	90	8	37	53	70	187 ±1,4	134

Piston Ø	stroke tolerance
25	+2/-1
32	+2/-0

Piston Ø	stroke tolerance
40	+2/-0
50	+2/-0
63	+2,5/-0
80	+2,5/-0
100	+2,5/-0

Clevis mounting MP2, Series CM1

167
CCL-IC
CCL-IS



Piston diameter [mm]	Swivel bearing Ø [mm]	Material	Part No.
25	10	Aluminum	3682902590
32	10	Aluminum	3672903000
40	12	Aluminum	3672904000
50	12	Aluminum	3672905000
63	16	Aluminum	3672906000
80	16	Aluminum	3672908000
100	20	Aluminum	3672910000

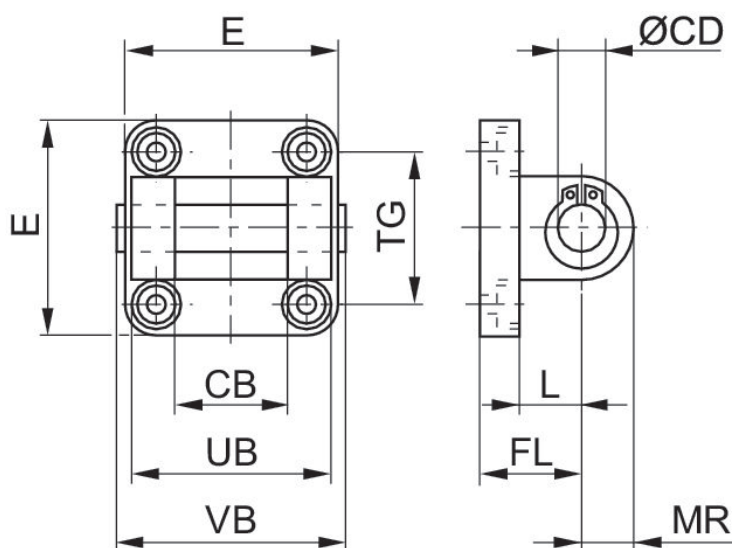

Part No.	Cylinders Ø	CB H14	Ø CD H9	E max.	FL	L min.	MR	UB h14	VB	TG *contains elongated hole
3682902590	25	18	10	40	20	14	9	36	42,5	26/27*
3672903000	32	26	10	47,5	22	12	11	45	64	32
3672904000	40	28	12	53,5	25	15	13	52	71	40*
3672905000	50	32	12	64	27	15	13	60	79	46
3672906000	63	40	16	74	32	18	17	70	93	59*
3672908000	80	50	16	95	36	20	17	90	113	73

Part No.	Cylinders Ø	CB H14	Ø CD H9	E max.	FL	L min.	MR	UB h14	VB	TG *contains elongated hole
3672910000	100	60	20	113,5	41	25	21	110	133	90*

Rear eye MP6, Series CM1

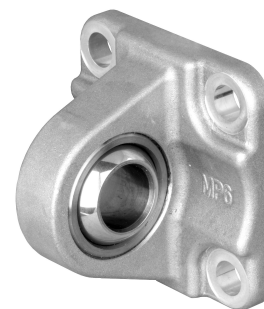

Piston diameter [mm]	Swivel bearing Ø [mm]	Standardization	Material	Part No.
25	10	ISO 21287	Aluminum	3663602000
32	10	ISO 6431	Aluminum	3663603000
40	12	ISO 6431	Aluminum	3663604000
50	12	ISO 6431	Aluminum	3663605000
63	16	ISO 6431	Aluminum	3663606000
80	16	ISO 6431	Aluminum	3663608000
100	20	ISO 6431	Aluminum	3663610000

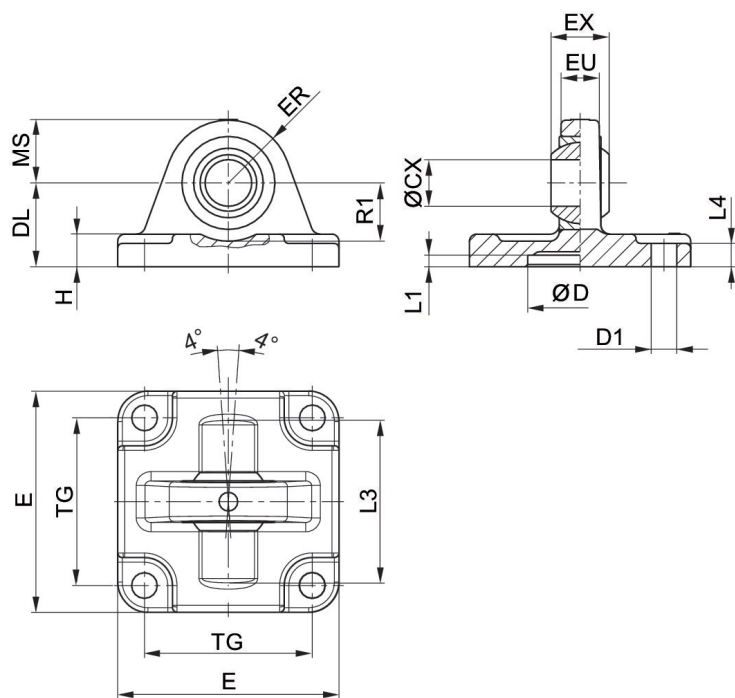

Scope of delivery: clevis incl. mounting screws

Piston Ø	Part No.	ØCX H7	ØD H11	ØD1 H13	DL ±0,2	E	EX -0,1	ER	EU	H
25	3663602000	10	18	5,5	20	40	9	14	8	6
32	3663603000	10	20	5,5	22	46	9	15	8	6

Piston Ø	Part No.	ØCX H7	ØD H11	ØD1 H13	DL ±0,2	E	EX -0,1	ER	EU	H
40	3663604000	12	30	6.6	28	55	12	17	9.5	8
52,5	3663605000	12	40	6,6	28	62	12	17	9.5	9
63	5220163442	10	-	7.5	29	45	14	15	10.5	8
75	3663606000	16	55	9	36	80	16	25	12,5	11
80	5220363442	12	-	10	26	65	16	18	12	10
80	3663608000	16	70	9	38	94	16	28	12,5	12
85, 95	5220463442	16	-	10	30	75	21	22	15	10
100	3663610000	20	90	11	43	114	20	35	16	15
115	5220563442	16	-	12	37.5	95	21	25	15	12

Piston Ø	L1 min.	L3	L4	MS -0,5	R1 min.	TG
25	3	-	3	14	-	26
32	0.5	42	6	15	16	32
40	0.5	48	8	17	16	32
52,5	0,5	55	9	17	18	46
63	-	-	-	-	-	33
75	0,5	70	11	25	21	59
80	-	-	-	-	-	49
80	0,5	80	12	28	21	73
85, 95	-	-	-	-	-	59
100	0,5	100	15	35	28	90
115	-	-	-	-	-	75

Rear eye MP9, Series CM1

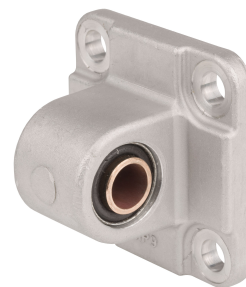

Piston diameter [mm]	Swivel bearing Ø [mm]	Standardization	Material	Part No.
32	10	ISO 15552	Aluminum	3683203000
40	12	ISO 15552	Aluminum	3683204000
63	16	ISO 15552	Aluminum	3683206000
100	20	ISO 15552	Aluminum	3683210000
25	10	ISO 21287	Die-cast aluminum	3683202000
50	12		Aluminum	3663205000
80	16		Aluminum	3663208000

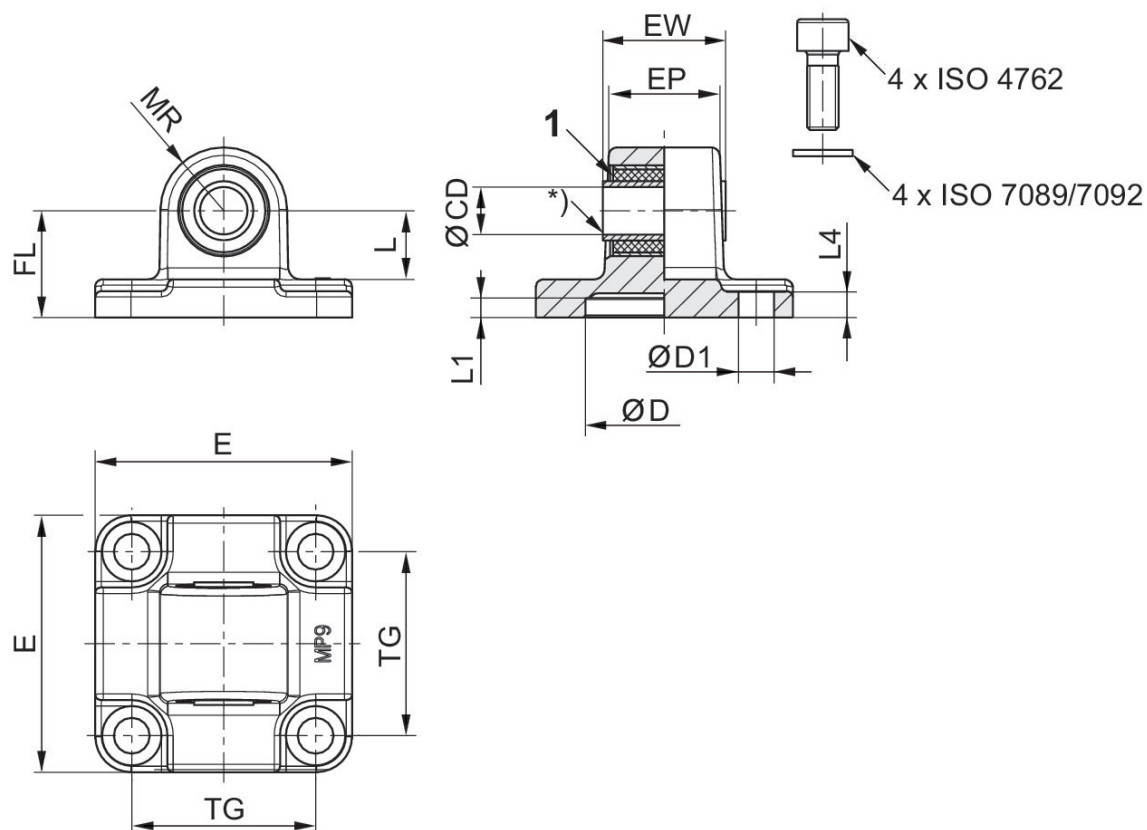

1) Rubber bushing

Piston Ø	Part No.	CD H11	CD H9	E	EW	EP	TG	TG1 ±0,2	FL ±0,2	L 1)
32	3683203000	10	-	46	25.5	18,9	32.5	-	22	13.8
50	3683205000	-	12	65	31	28	46.5	-	27	17.3
50	3663205000		12	63	31		46		28	15.5
80	3663208000		16	95	49.5		73		38	20.5
80	3683208000	-	16	94.5	49.5	43	72	-	36	21.8
125	R412015973	-	25	138	69.5	60	110	-	50	33.8

Piston Ø	MR	L1	L4	D H11	D1 H13
32	12.5	5	5.5	30	6.6
50	16	5	6.5	40	9
50	18				
80	24				
80	22	5	10	45	11
125	34	7.5	10	60	13.5

3683204000, 3683206000, 3683210000, 3683202000

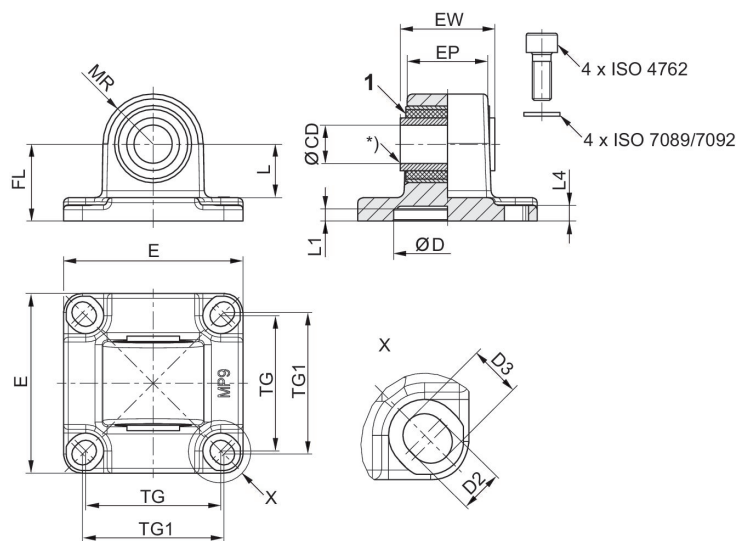

1) Rubber bushing

Trunnion mounting MT4, Series CM1

167



Piston diameter [mm]	Material	Part No.
32	Steel, chrome-plated	3672803000
40	Steel, chrome-plated	3672804000
50	Steel, chrome-plated	3672805000
63	Steel, chrome-plated	3672806000
80	Steel, chrome-plated	3672808000
100	Steel, chrome-plated	3672810000

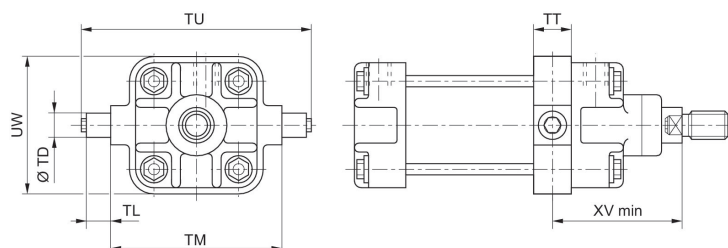

Piston Ø	Part No.	TT	TD e9	TL h14	TM h14	TU	UW	XV min
32	3672803000	16	12	12	50	74	48	61,5
40	3672804000	23	16	16	63	95	61	74,5
50	3672805000	23	16	10	75	107	71	79,5
63	3672806000	33	20	20	90	130	86	91,5
80	3672808000	33	20	20	110	150	112	100,5
100	3672810000	45	25	25	132	182	134	115,5

Bearing, Series CM1



Piston diameter [mm]	Swivel bearing \varnothing [mm]	Material	Part No.
25	10	Aluminum	3671202000
32	12	Aluminum	3671203000
40, 50	16	Aluminum	3671204000
63, 80	20	Aluminum	3671206000
100, 125	25	Aluminum	3671210000

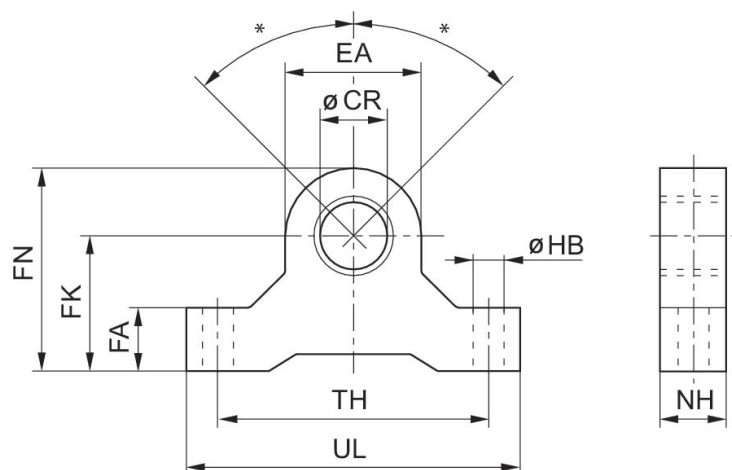

* Max. pendulum movement for cylinders with rear eye MP6 with ball joint: $\pm 45^\circ$

Piston \varnothing	Part No.	\varnothing CR H8	EA	FA	FK $\pm 0,1$	FN	HB	NH	TH	UL
25	3671202000	10	16	10	21	29	5.5	10	27	37
32	3671203000	12	19	11	22	32	6.6	11	44	55
40, 50	3671204000	16	28	16	35	49	9	16	65	82
63, 80	3671206000	20	38	19	40	59	9	19	80	99
100, 125	3671210000	25	46	22	48	71	11	22	96	118
100	3671212000	30	56	28	57	88	13	28	114	142
160, 200	3671216000	32	66	32	70	103	17	32	140	172
250, 320	3671220000	35	66	32	70	103	17	32	140	172

Foot mounting MS1, Series CM1



Piston diameter [mm]	for series	Material	Part No.
25	167	Steel, chrome-plated	3682202000
32	167	Steel, chrome-plated	3662203000
40	167	Steel, chrome-plated	3662204000
50	167	Steel, chrome-plated	3662205000
63	167	Steel, chrome-plated	3662206000
80	167	Steel, chrome-plated	3662208000
100	167	Steel, chrome-plated	3662210000

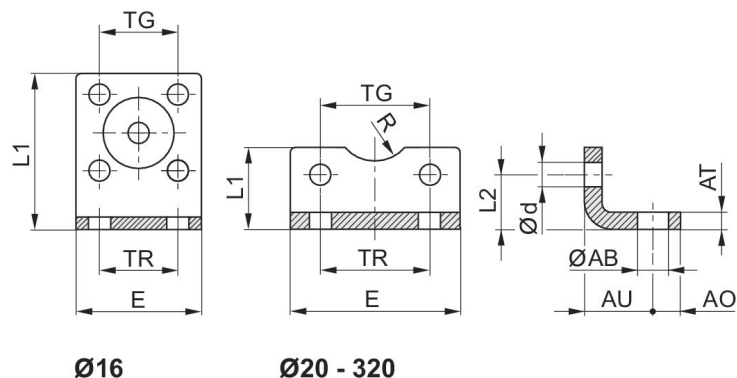

Piston Ø	Part No.	ØAB	AO	AT	AU ±0,2	Ød	E	L1	L2	R
16	1821332053	5.5	5	3	13	4.5	29	35.5	13	8
20	1827002284	6.6	6	4	16	5.4	36	22	16	10
25	1827002285	6.6	6	4	16	5.4	40	23	17	11
25	3682202000	7	8	4	22	5.5	40	21	11.5	13.5
32	1827002286	6.6	8	5	18	6.6	50	24	16	-
32	1827001271	7	8	4 ±0,3	24	6.6	48	25	15.5	15
32	3662203000	7	8	5	24	5.5	47	26	16	15
40	1827002287	9	8	5	20	6.6	60	29.5	21.5	-
40	1827001272	10	10	4 ±0,3	28	6.6	56	26	17	17.5
40	3662204000	9	11	5	31	6.6	56	28	16	20
50	1827002288	9	8	6	24	9	68	30	22	-

Piston Ø	Part No.	ØAB	AO	AT	AU ±0,2	Ød	E	L1	L2	R
50	1827001273	10	11	5 ±0,3	32	9	68	32	21.5	20
50	3662205000	9	12	6	33	6.6	63	35	22	23
63	1827002289	11	12	6	27	9	84	39	28.5	–
63	1827001498	10	13	5 ±0,3	32	9	78	34	21.5	22.5
63	3662206000	9	12	6	36	9	81	40	20.5	23
80	1827002290	11	12	8	30	11	102	36.5	24.5	–
80	1827001275	12	16	6 ±0,5	41	11	98	47	27	22.5
80	3662208000	12	15	8	43	9	95	45	26.5	26
100	1827002291	13.5	12	8	33	11	123	38.5	26.5	–
100	1827001276	14.5	19	6 ±0,5	41	11	117	52	26.5	27.5
100	3662210000	14	17	10	43	11	115	50	26	32
125	1827001310	16.5	20	8 ±1,0	45	13.5	144	69	35	30
160	1827001457	18.5	23	10 ±1,0	60	17.5	185	100	45	32.5
200	1827001458	24	26	12 ±1,0	70	17.5	220	120	47.5	37.5
250	1827001459	28	33	20 ±1,0	75	22	280	135	55	45
320	5239010502	35	45	23 ±1,0	85	26	350	200	65	55

Piston Ø	TG	TR
16	18 ±0,2	18
20	22 ±0,2	22
25	26 ±0,2	26
25	27	26
32	32	32
32	32,5 ±0,2	32
32	32	32
40	42	42
40	38 ±0,2	36
40	40	36
50	50	50
50	46,5 ±0,2	45
50	46	45
63	62	62
63	56,5 ±0,2	50
63	59	50
80	82	82
80	72 ±0,2	63
80	73	63
100	103	103
100	89 ±0,2	75
100	90	75
125	110 ±0,3	90
160	140 ±0,3	115
200	175 ±0,3	135
250	220 ±0,3	165
320	270 ±0,3	200

Bolts AA4, Series CM1



Piston diameter [mm]	Material	Surface	Part No.
25, 32	Steel, chrome-plated	nitrocarburized	3661302000
40, 50	Steel, chrome-plated	nitrocarburized	3661303000
63, 80	Steel, chrome-plated	nitrocarburized	3661304000
100	Steel, chrome-plated	nitrocarburized	3661306000

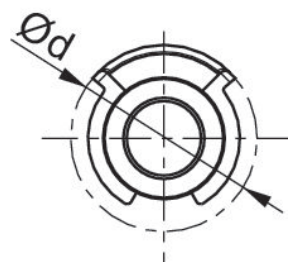
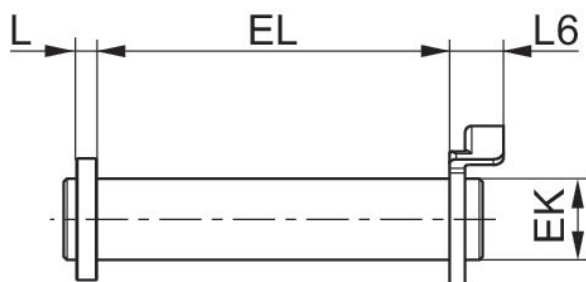

Piston \varnothing	Part No.	$\varnothing d$ max.	EK e8	EL	L max.	L6 max.
32	1823120020	20	10	45.2 +0,3	3.5	9
40	1823120021	22	12	52.2 +0,3	4	9
50	1823120022	22	12	60.2 +0,3	4	9
63	1823120023	28	16	70.2 +0,3	4.5	11
80	1823120024	28	16	90.2 +0,3	4.5	11
100	1823120025	38	20	110.2 +0,3	5	11

3661302000, 3661303000, 3661304000, 3661306000

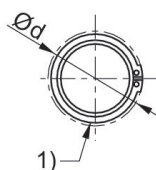
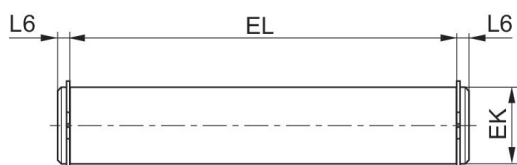

1) circlip DIN 471

Compensating coupling PM5, series CM2



Thread size	Material	Part No.
M10x1,25	Steel, chrome-plated	R412026142
M12x1,25	Steel, chrome-plated	R412026143
M16x1,5	Steel, chrome-plated	R412026144
M20x1,5	Steel, chrome-plated	R412026145

Dimensions

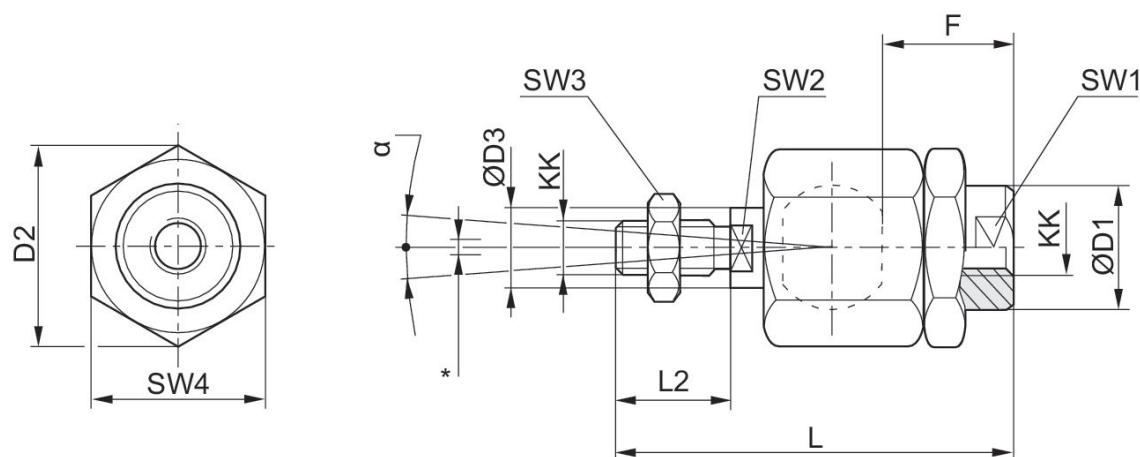

* Radial joint

KK	Part No.	Ø D1	D2	Ø D3	F	L ±2	L2	SW1	SW2	SW3
M4	1826409008	12	13.5	4	13	33	8	12	3.2	7
M5	R412007860	8.5	14.8	6	12	38.5	13.5	7	5	8
M6x1	R412026140	8.5	14.5	6	11	36.5	11	7	5	10
M8x1.25	R412026141	12.5	19	8	21	58	21	11	7	13
M10x1.25	R412026142	22	32	14	23	74.5	23	19	12	17
M12x1.25	R412026143	22	32	14	24	75	24	19	12	19
M16x1.5	R412026144	32	45	22	30	103	30	30	20	24
M20x1.5	R412026145	32	45	22	40	119	40	30	20	30
M27x2	1826409006	62	62	28	48	147	54	32	24	41
M36x2	1826409007	80	80	38	86	241	72	50	36	55
M42x2	R412007729	64	98	42	96	271	82	60	36	65

KK	SW4	α [°]	1)	2)
M4	12	8	0.05-0.2	0-0,5
M5	13	8	0.05-0.2	0-0,5
M6x1	13	6	0.05-0.5	0-1,5
M8x1.25	17	8	0.05-0.5	0-1,5
M10x1.25	30	8	0.05-0.5	0-2
M12x1.25	30	7	0.05-0.5	0-2
M16x1.5	41	6	0.05-0.5	0-2
M20x1.5	41	6	0.05-0.5	0-2
M27x2	55	8	0.05-0.2	0-2
M36x2	75	8	0.05-0.2	0-2
M42x2	85	8	0.05-0.2	0-2

1) Axial play
2) Radial play

Compensating coupling PM7, series CM2



Thread size	Material	Part No.
M10x1,25	Steel, chrome-plated	1827001629
M12x1,25	Steel, chrome-plated	1827001630
M16x1,5	Steel, chrome-plated	1827001631
M20x1,5	Steel, chrome-plated	1827001632

Dimensions

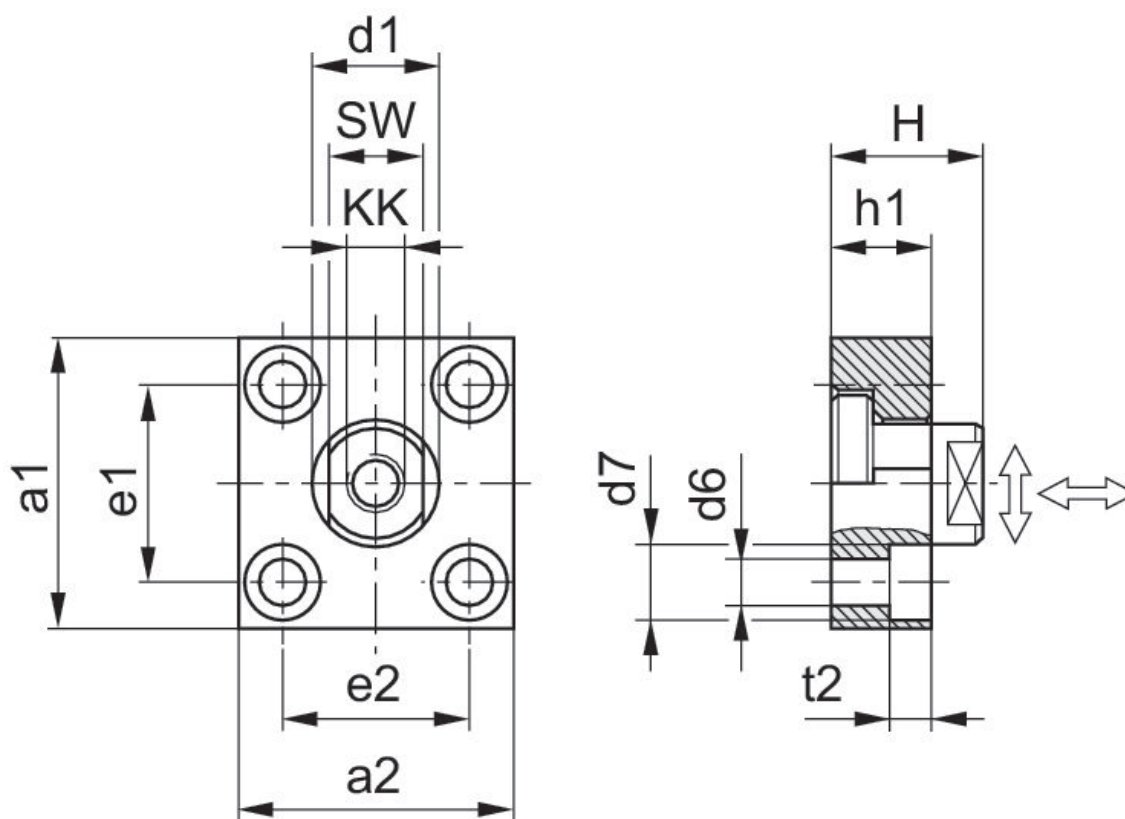

KK	Part No.	a1	a2	d1 h11	d6 H13	d7 H13	e1 H13	e2	h1	t2
M10x1.25	1827001629	60	37	20	6.6	11	36 ±0,15	23 ±0,15	15	7
M12x1.25	1827001630	60	56	25	9	15	42 ±0,2	38 ±0,2	20	9
M16x1.5	1827001631	80	80	30	11	18	58 ±0,2	58 ±0,2	20	11

KK	Part No.	a1	a2	d1 h11	d6 H13	d7 H13	e1 H13	e2	h1	t2
M20x1.5	1827001632	90	90	40	14	20	65 ±0,3	65 ±0,3	20	13
M27x2	1827001633	90	90	40	14	20	65 ±0,3	65 ±0,3	20	13
M36x2	1827001634	125	125	60	18	26	90 ±0,3	90 ±0,3	30	17

KK	H	SW	Tightening torque for the coupling pin Ma ± 5%	Axial play min./max.	Radial play min./max.
M10x1.25	24	17	17 Nm	0,4 - 0,8 mm	1,9 - 2,3 mm
M12x1.25	30	19	29 Nm	0,4 - 0,8 mm	1,9 - 2,3 mm
M16x1.5	32	24	71 Nm	0,4 - 0,8 mm	1,9 - 2,3 mm
M20x1.5	35	36	138 Nm	0,4 - 0,8 mm	1,9 - 2,3 mm
M27x2	35	36	350 Nm	0,4 - 20,31 mm	1,9 - 2,3 mm
M36x2	55	50	1080 Nm	0,4 - 0,95 mm	2,8 - 3,4 mm

Rod clevis AP2, Series CM2

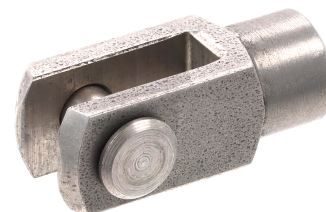

for series	Material	Part No.
CCL-IS, CCL-IC, CCI, CSL-RD, SSI, ICM, ICS-D2, 167	Stainless Steel	3590502000
CCL-IS, CCL-IC, CCI, SSI, 167, ICS-D2	Stainless Steel	3590504000
CCL-IS, ICS-D2, 167	Stainless Steel	3590505000
CCL-IS, ICS-D2, 167	Stainless Steel	3590508000

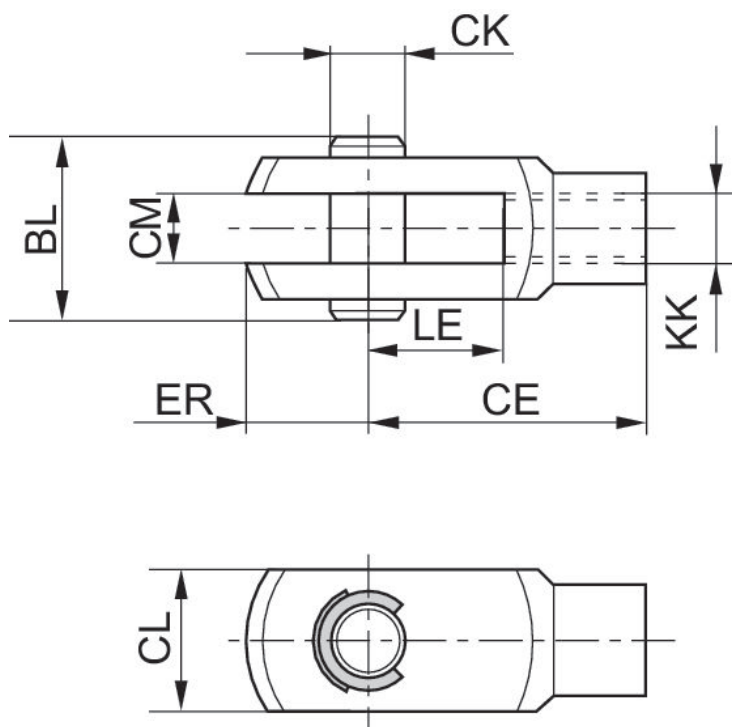

KK	Part No.	CE	CK e8	CL	CM B12	ER	BL	LE
M4	3330510000	16	4	10	5	6	15	8
M6	3330516000	24	6	12	6	7	17	12
M8	3330520000	32	8	16	8	10	22	16
M10x1,25	3590502000	40	10	20	10	12	26	20
M12x1,25	3590504000	48	12	24	12	14	31	24
M16x1,5	3590505000	64	16	32	16	19	39	32

KK	Part No.	CE	CK e8	CL	CM B12	ER	BL	LE
M20x1,5	3590508000	80	20	40	20	20	49	40

Rod clevis AP2, Series CM2

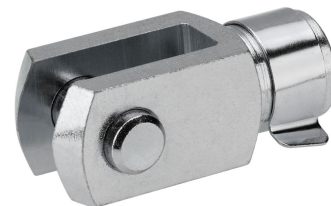

for series	Material	Part No.
PRA, TRB, CCI, MNI, ICM, KPZ, 167, CVI, RPC, RDC	Steel, chrome-plated	1822122024
PRA, TRB, CCI, KPZ, 167, CVI, RPC, 102	Steel, chrome-plated	1822122025
PRA, TRB, CCI, KPZ, 167, CVI, RPC, RDC, 102	Steel, chrome-plated	1822122005
PRA, TRB, KPZ, 167, CVI, 102	Steel, chrome-plated	1822122004
ITS	Steel, chrome-plated	8958019332

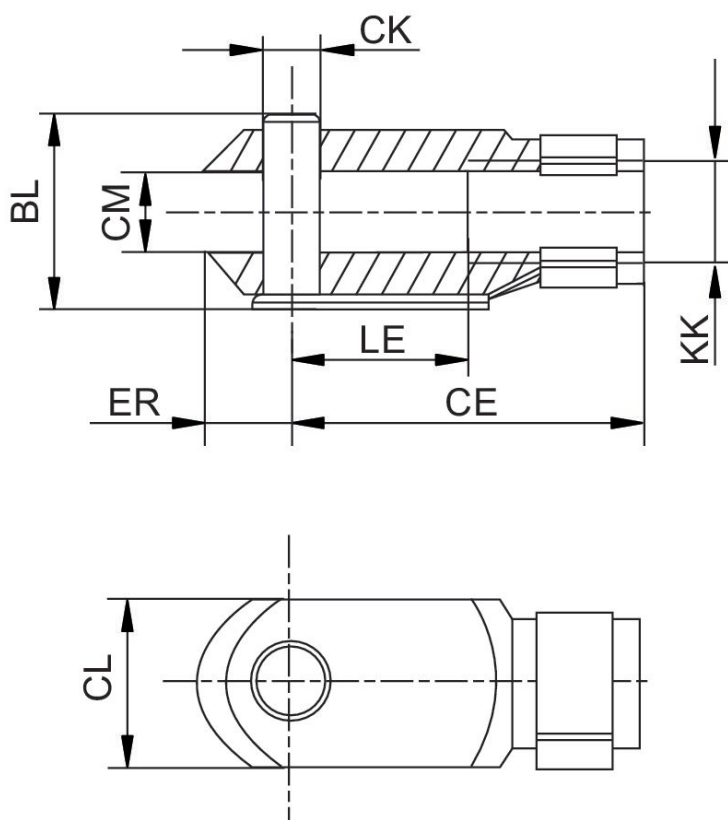

KK	Part No.	BL	CE	ØCK e11	CL	CM	ØD1	ER	LE
M4	1822122028	11	16	4	8	4	8	5	8
M6	1822122009	16	24	6	12	6	10	7	12
M8	1822122010	21,5	32	8	16	8	14	10	16

KK	Part No.	BL	CE	ØCK e11	CL	CM	ØD1	ER	LE
M10x1,25	1822122024	26	40	10	20	10	18	12	20
M12x1,25	1822122025	31	48	12	24	12	20	14	24
M16x1,5	1822122005	39	64	16	32	16	26	19	32
M20x1,5	1822122004	50	80	20	40	20	34	20	40
M10	8958000122	26	40	10	20	10	18	12	20
M12	8958000132	31	48	12	24	12	20	14	24
M48x2	8958019332	122	192	50	96	50	82	73	96
M5	1822122008	13.5	20	5	10	5	9	6	10

Rod clevis PM6, Series CM2



for series	Swivel bearing Ø [mm]	Material	Part No.
AP6	14	Steel, chrome-plated	1822122032
AP6	16	Steel, chrome-plated	1822122033
AP6	21	Steel, chrome-plated	1822122034
AP6	25	Steel, chrome-plated	1822122035

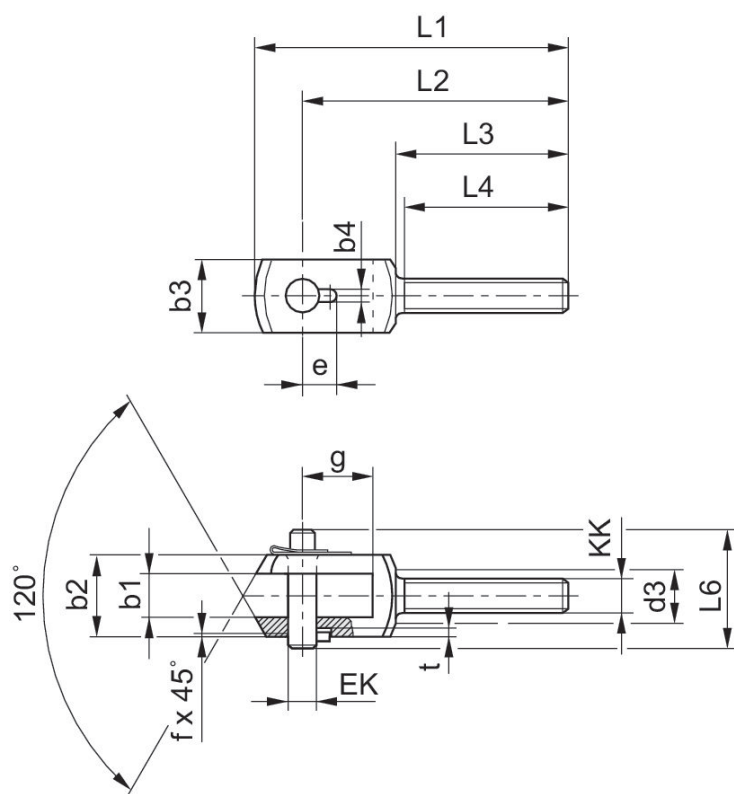

KK	Part No.	b1 B12	b2 d12	b3	b4 +0,2	d3	e +0,3	EK	f	g
14	1822122032	14	28	20	3.3	17	11.5	10	0.7	20
16	1822122033	16	30	25	4.3	19	12	12	1	26
21	1822122034	21	40	35	4.3	24	14	16	1	31
25	1822122035	25	50	40	4.3	30	16	20	1	43

KK	Part No.	b1 B12	b2 d12	b3	b4 +0,2	d3	e +0,3	EK	f	g
30	1822122036	37	67	60	6.3	38	24	30	1.5	54

KK	L1	L2	L3	L4 +1	L6	t +0,2
14	90	78	53	50	35	3
16	108	92	58	55	39	3
21	129	108	65	62	50	3
25	156	131	73	69	60	3
30	200	168	98	92	77	5

Rod clevis AP2, Series CM2



for series	Material	Part No.
PRA, TRB, CCL-IS, 167, CVI	Steel, chrome-plated	1827001493

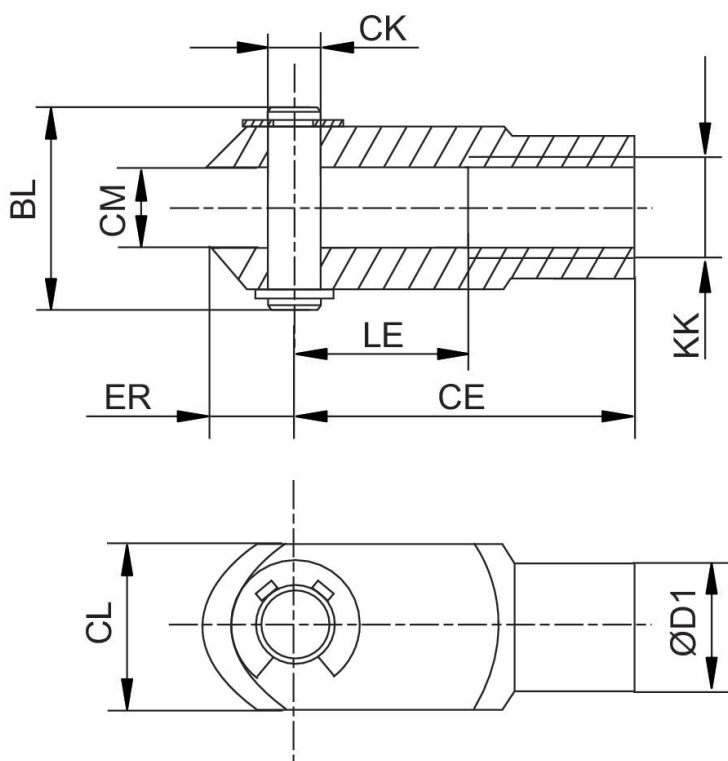

KK	Part No.	BL	CE	ØCK e11	CL	CM	ØD1	ER	LE
M27x2	1827001493	68	110	30	55	30	48	38	54
M36x2	1827001471	80	144	35	70	35	60	57	72
M42x2	1827001472	98	168	40	85	40	70	64	84

Ball eye rod end AP6, series CM2



for series	Swivel bearing \varnothing [mm]	Material	Part No.
PRA, TRB, MNI, CCI, SSI, RPC, KPZ, 167, CVI, RDC	10	Steel, chrome-plated	1822124003
PRA, TRB, CCI, SSI, RPC, KPZ, 167, CVI, 102	12	Steel, chrome-plated	1822124004
PRA, TRB, CCI, SSI, RPC, KPZ, 167, CVI, RDC, 102	16	Steel, chrome-plated	1822124005
PRA, TRB, KPZ, 167, CVI, 102	20	Steel, chrome-plated	1822124006
PRA, TRB, 167, CVI	30	Steel, chrome-plated	1822124013
ITS	35	Steel, chrome-plated	1822124008
ITS	40	Steel, chrome-plated	1822124009
ITS	50	Steel, chrome-plated	8958208842

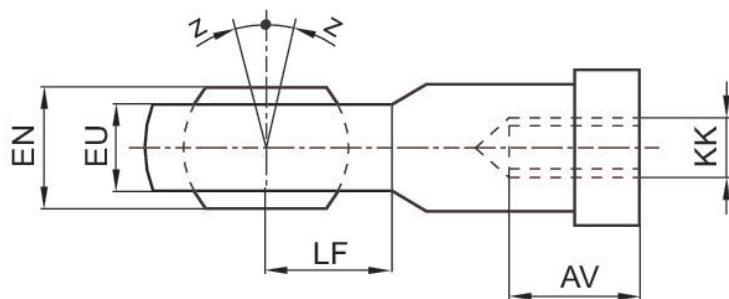
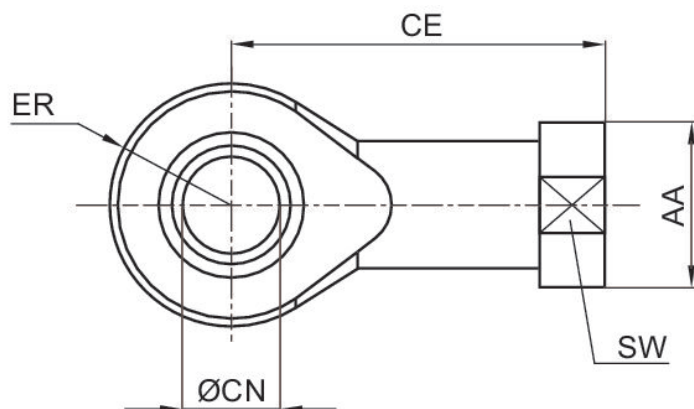

KK	Part No.	AA	AV min.	CE	Ø CN H7	EN -0,1	ER	EU max.	LF	SW
M4	1822124000	12	8	27	5	8	9	7.5	9	9
M6	1822124001	13	9	30	6	9	10	7.5	10	11
M8	1822124002	16	12	36	8	12	12	9.5	12	14
M10	8958206402	19	20	43	10	14	14	10.5	13	17
M12	8958208852	22	22	50	12	16	16	12	16	19
M10x1,25	1822124003	19	15	43	10	14	14	11.5	14	17
M12x1,25	1822124004	22	18	50	12	16	16	12.5	16	19
M16x1,5	1822124005	27	24	64	16	21	21	15.5	21	22
M20x1,5	1822124006	34	30	77	20	25	25	18.5	25	30
M24x2	8958208002	42	36	94	25	31	30	23	30	36
M27x2	1822124013	50	45	110	30	37	35	27	35	41
M36x2	1822124008	60	56	125	35	43	40	32	40	50
M42x2	1822124009	69	60	142	40	49	45.5	37	45	55
M48x2	8958208842	75	65	160	50	60	58	45	60	65

KK	Z [°] max.
M4	4
M6	4
M8	4
M10	6
M12	13
M10x1,25	4
M12x1,25	4
M16x1,5	4
M20x1,5	4
M24x2	15
M27x2	4
M36x2	4
M42x2	4
M48x2	6

Piston rod nut MR9



Thread size	Material	Part No.
M24x2	Steel, chrome-plated	8103190394
M48x2	Steel, chrome-plated	8103190434
M12x1,25	Stainless Steel	3590304000
M16x1,5	Stainless Steel	3590305000
M20x1,5	Stainless Steel	3590308000

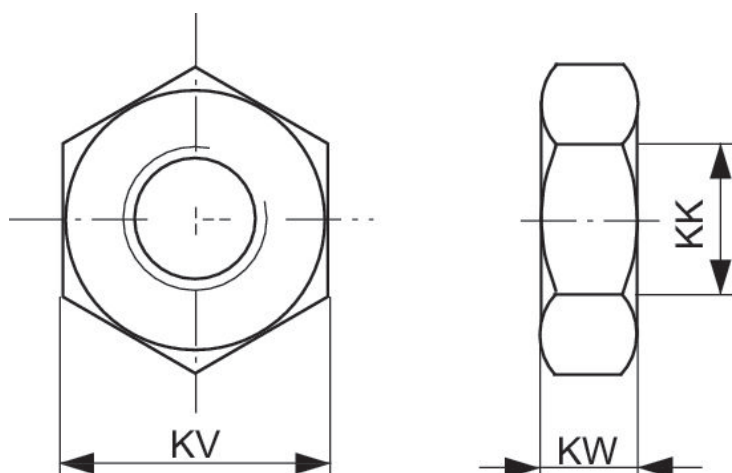

KK	Part No.	KV	KW
M4	1823300033	10	3.2
M6	1823300034	13	4
M8	1823A00021	19	6
M10	8103190344	19	6
M10x1,25	1823300030	24	8
M20x1,5	1823300031	30	10
M27x2	1823A00029	41	13.5
M36x2	8103190414	50	16
M42x2	8103190424	60	21
M6	8103190644	10	3.2
M8	8103190164	13	4

KK	Part No.	KV	KW
M10x1,25	8103190464	17	5
M4	3330310000	7	2.2
M12x1,25	3590304000	19	6
M16x1,5	3590305000	24	8
M20x1,5	3590308000	30	10
M20x1,5	8103040344	30	10
M24x2	8103190394	36	12
M48x2	8103190434	65	25
M10x1,25	2990600303	17	5
M12x1,25	2990600304	19	6
M16x1,5	2990600305	24	8
M20x1,5	2990600308	30	10
M27x2	2990600312	41	13.5
M36x2	2990600316	50	16
M42x2	2990600325	60	21

Sensor, Series ST6

PRA
PRE
CCI
KPZ
SSI
GPC
CVI
Plug
M12
ATEX
CE declaration of conformity
cULus
RoHS
UL (Underwriters Laboratories)

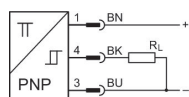

Direct mounting for series	Type of contact	Cable sheath	Cable length L [m]	Max. DC switching current [A]	Min. operating voltage DC [V DC]	Max. operating voltage DC [V DC]	Version	Part No.
PRA, PRE, CCI, KPZ, SSI, GPC, CVI	PNP	Polyurethane	0.3	0.1	10	30	short circuit resistant, Protected against polarity reversal	R412022864

Dimensions

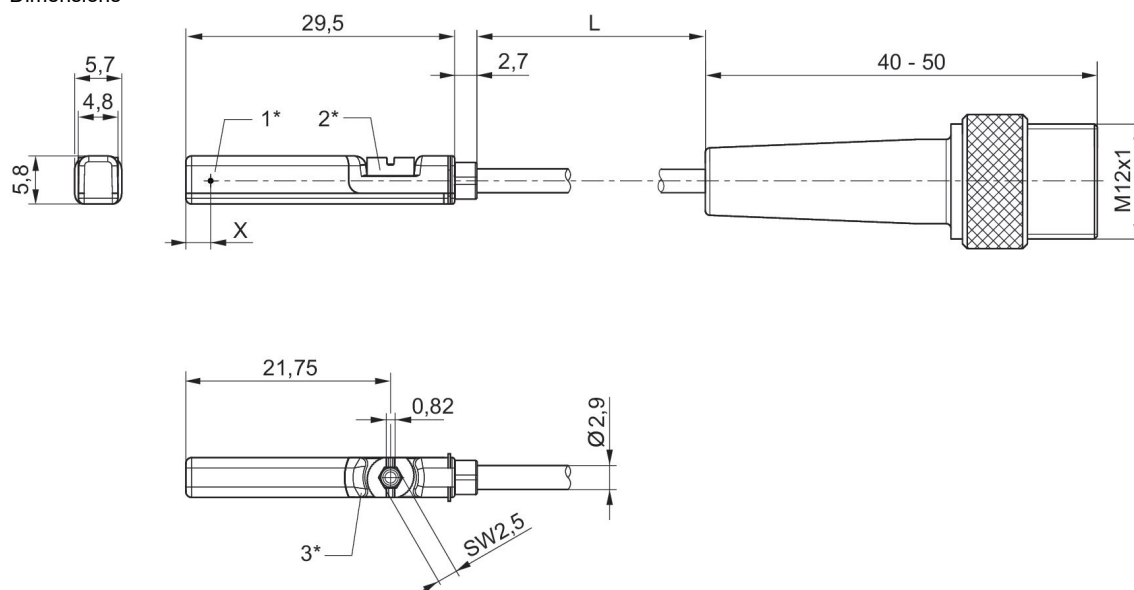

1* = switching point 2* = locking screw 3* = LED window, transparent
L = cable length
X = PNP: 11,6 mm, reed: 8,3 mm

Sensor, Series ST6

PRA
PRE
CCI
KPZ
SSI
GPC
CVI
Plug
M8
CE declaration of conformity
cULus
RoHS
UL (Underwriters Laboratories)



Direct mounting for series	Type of contact	Cable sheath	Cable length L [m]	Max. DC switching current [A]	Max. AC switching current [A]	Min. operating voltage DC [V DC]	Max. operating voltage DC [V DC]	Min. operating voltage AC [V AC]	Max. operational voltage AC [V AC]	Version	Part No.
PRA, PRE, CCI, KPZ, SSI, GPC, CVI	Reed	Polyurethane	0.3	0.13	0.13	10	30	10	30	Protected against polarity reversal	R412022868
PRA, PRE, CCI, KPZ, SSI, GPC, CVI	Reed	Polyurethane	0.3	0.13	0.13	10	30	10	30	Protected against polarity reversal	R412027172
PRA, PRE, CCI, KPZ, SSI, GPC, CVI	Reed	Polyurethane	0.3	0.3	0.5	10	30	10	30	Protected against polarity reversal	R412022872
PRA, PRE, CCI, KPZ, SSI, GPC, CVI	electron PNP	Polyurethane	0.3	0.13		10	30			short circuit resistant, Protected against polarity reversal	R412022858
PRA, PRE, CCI, KPZ, SSI, GPC, CVI	NPN	Polyurethane	0.3	0.13		10	30			short circuit resistant, Protected against polarity reversal	R412022851

Dimensions

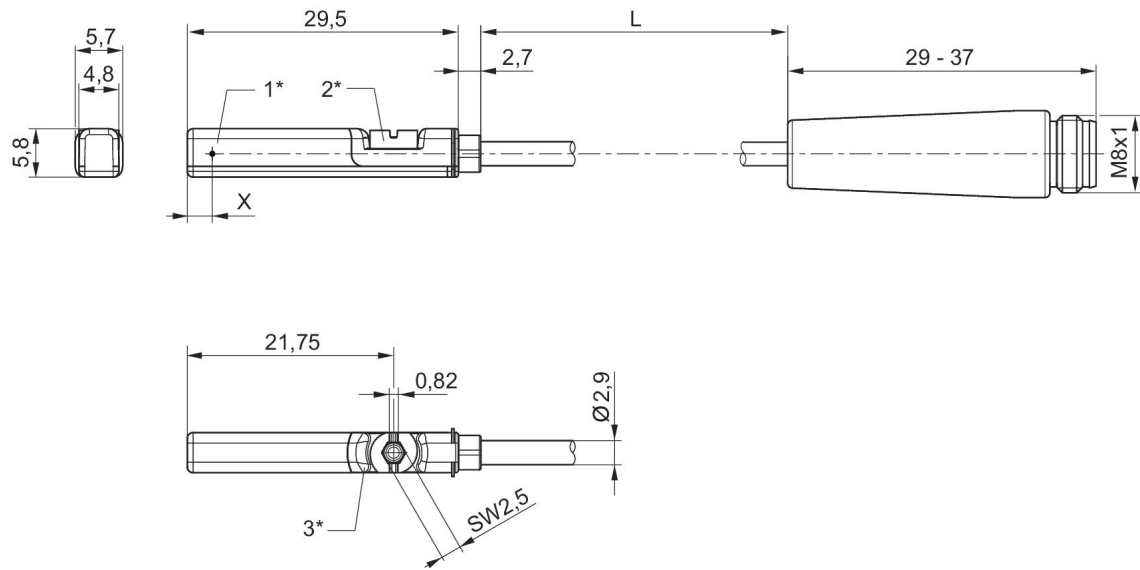

1* = switching point 2* = locking screw 3* = LED window, transparent
 L = cable length
 X = electronic: 11,6 mm, Reed: 8,3 mm

Sensor, Series ST6

PRA
PRE
CCI
KPZ
SSI
GPC
CVI
Plug
CE declaration of conformity
cULus
RoHS
UL (Underwriters Laboratories)



Direct mounting for series	Type of contact	Cable sheath	Cable length L [m]	Max. DC switching current [A]	Max. AC switching current [A]	Min. operating voltage DC [V DC]	Max. operating voltage DC [V DC]	Min. operating voltage AC [V AC]	Max. operational voltage AC [V AC]	Version	Part No.
PRA, PRE, CCI, KPZ, SSI, GPC, CVI	Reed	Polyurethane	0.3	0.3	0.5	10	30	10	30	Protected against polarity reversal	R412022873
PRA, PRE, CCI, KPZ, SSI, GPC, CVI	Reed	Polyvinyl chloride	0.3	0.3	0.5	10	30	10	30	Protected against polarity reversal	R412022875
PRA, PRE, CCI, KPZ, SSI, GPC, CVI	Reed	Polyurethane	0.5	0.3	0.5	10	30	10	30	Protected against polarity reversal	R412022874
PRA, PRE, CCI, KPZ, SSI, GPC, CVI	electronic PNP	Polyurethane	0.3	0.13		10	30			short circuit resistant, Protected against polarity reversal	R412022859
PRA, PRE, CCI, KPZ, SSI, GPC, CVI	electronic PNP	Polyvinyl chloride	0.3	0.13		10	30			short circuit resistant, Protected against polarity reversal	R412022862
PRA, PRE, CCI, KPZ, SSI, GPC, CVI	electronic PNP	Polyurethane	0.5	0.13		10	30			short circuit resistant, Protected against polarity reversal	R412022861
PRA, PRE, CCI, KPZ, SSI, GPC, CVI	NPN	Polyurethane	0.3	0.13		10	30			short circuit resistant, Protected against polarity reversal	R412022852

Dimensions

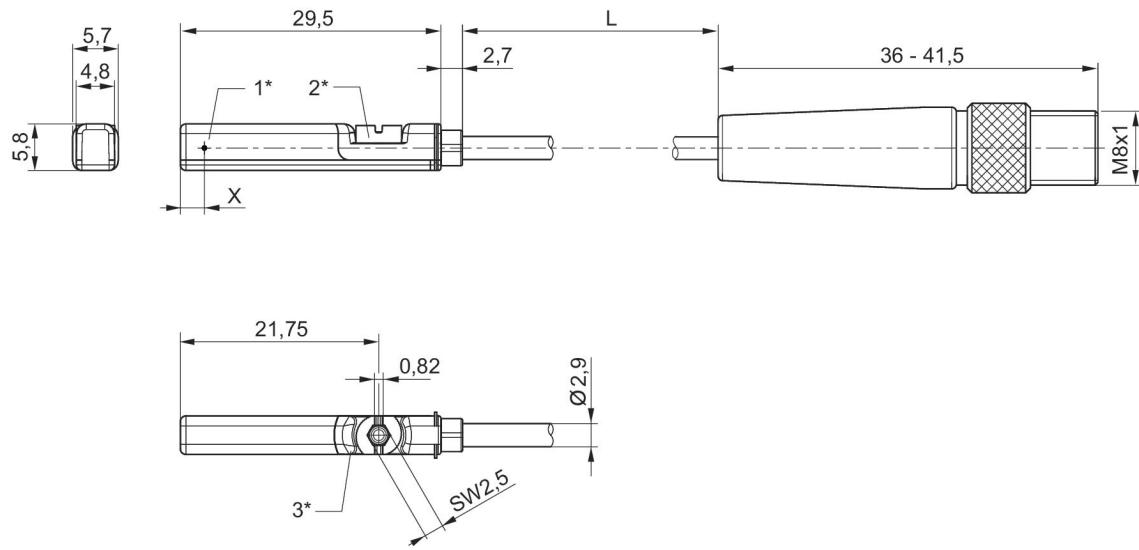

1* = switching point 2* = locking screw 3* = LED window, transparent
 L = cable length
 X = electronic: 11,6 mm, Reed: 8,3 mm

Sensor, Series ST6

PRA
PRE
CCI
KPZ
SSI
GPC
CVI
Plug
M12
CE declaration of conformity
cULus
RoHS
UL (Underwriters Laboratories)



Direct mounting for series	Type of contact	Cable sheath	Cable length L [m]	Max. DC switching current [A]	Max. AC switching current [A]	Min. operating voltage DC [V DC]	Max. operating voltage DC [V DC]	Min. operating voltage AC [V AC]	Max. operational voltage AC [V AC]	Version	Part No.
PRA, PRE, CCI, KPZ, SSI, GPC, CVI	Reed	Polyurethane	0.3	0.13	0.13	10	30	10	30	Protected against polarity reversal	R412027171
PRA, PRE, CCI, KPZ, SSI, GPC, CVI	Reed	Polyurethane	0.3	0.3	0.5	10	30	10	30	Protected against polarity reversal	R412022876
PRA, PRE, CCI, KPZ, SSI, GPC, CVI	electron PNP	Polyurethane	0.1	0.13		10	30			short circuit resistant, Protected against polarity reversal	R412022879
PRA, PRE, CCI, KPZ, SSI, GPC, CVI	electron PNP	Polyurethane	0.3	0.13		10	30			short circuit resistant, Protected against polarity reversal	R412022863
PRA, PRE, CCI, KPZ, SSI, GPC, CVI	electron PNP	Polyurethane	3	0.13		10	30			short circuit resistant, Protected against polarity reversal	R412022877
PRA, PRE, CCI, KPZ, SSI, GPC, CVI	electron PNP	Polyurethane	5	0.13		10	30			short circuit resistant, Protected against polarity reversal	R412022878

Dimensions

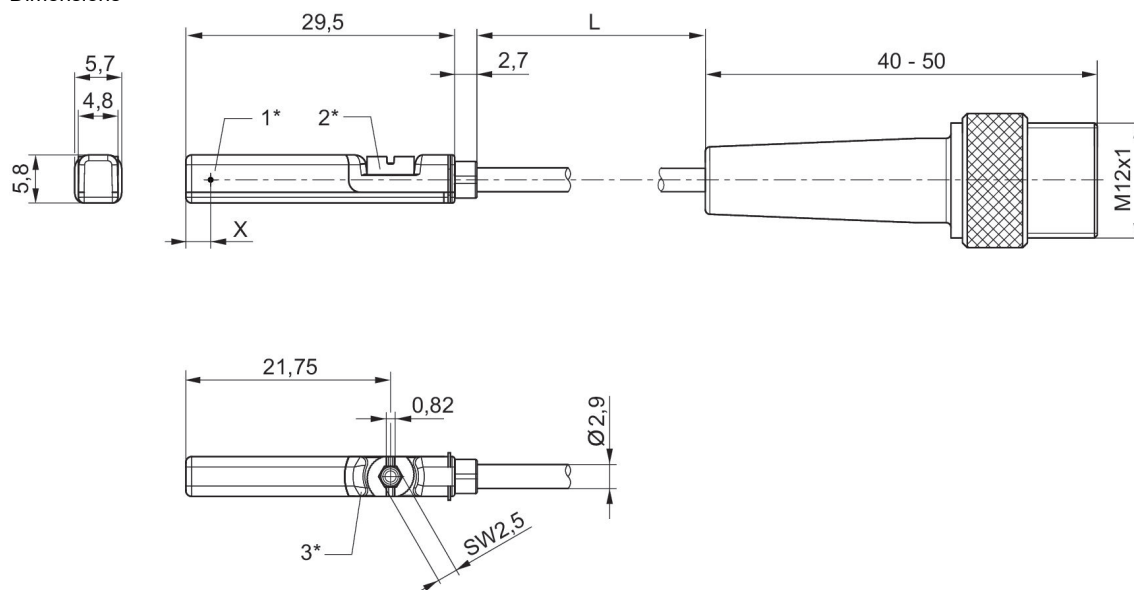

1* = switching point 2* = locking screw 3* = LED window, transparent
 L = cable length
 X = PNP: 11,6 mm, reed: 8,3 mm

Sensor, Series ST6

PRA
PRE
CCI
KPZ
SSI
GPC
CVI
Plug
M8
ATEX
CE declaration of conformity
cULus
RoHS
UL (Underwriters Laboratories)

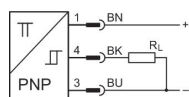

Direct mounting for series	Type of contact	Cable sheath	Cable length L [m]	Max. DC switching current [A]	Min. operating voltage DC [V DC]	Max. operating voltage DC [V DC]	Version	Part No.
PRA, PRE, CCI, KPZ, SSI, GPC, CVI	PNP	Polyurethane	0.3	0.1	10	30	short circuit resistant, Protected against polarity reversal	R412022860

Dimensions

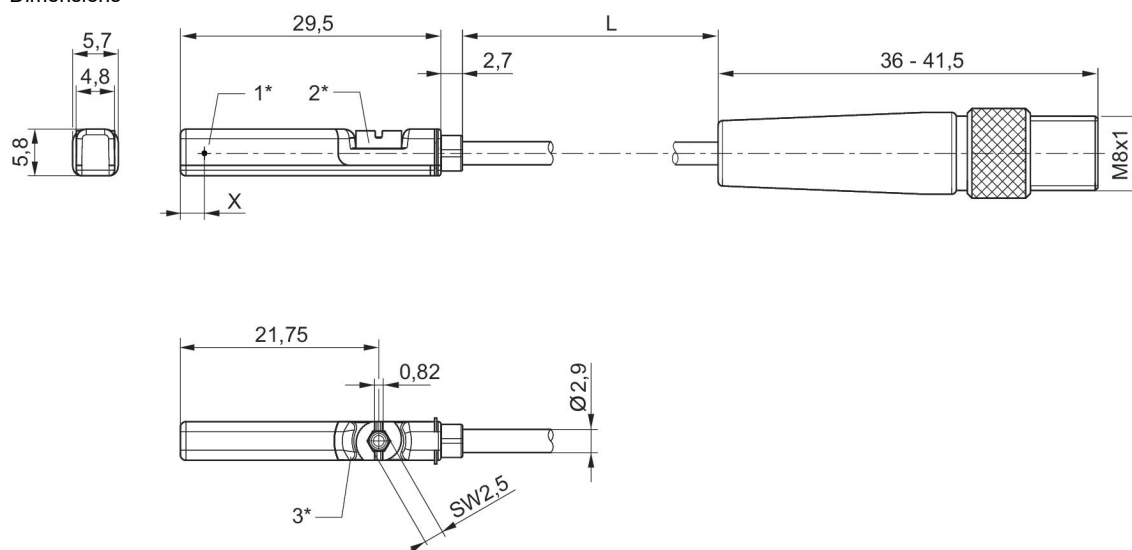

1* = switching point 2* = locking screw 3* = LED window, transparent
L = cable length
X = electronic: 11,6 mm, Reed: 8,3 mm

Sensor, Series ST6

PRA
PRE
CCI
KPZ
SSI
GPC
CVI
without wire end ferrule, tin-plated
CE declaration of conformity
cULus
RoHS
UL (Underwriters Laboratories)

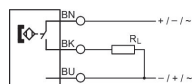

Direct mounting for series	Type of contact	Cable sheath	Cable length L [m]	Max. DC switching current [A]	Max. AC switching current [A]	Min. operating voltage DC [V DC]	Max. operating voltage DC [V DC]	Min. operating voltage AC [V AC]	Max. operational voltage AC [V AC]	Version	Part No.
PRA, PRE, CCI, KPZ, SSI, GPC, CVI	Reed	Polyurethane	3	0.13	0.13	10	230	10	230	Protected against polarity reversal	R412022866
PRA, PRE, CCI, KPZ, SSI, GPC, CVI	Reed	Polyurethane	5	0.13	0.13	10	230	10	230	Protected against polarity reversal	R412027170
PRA, PRE, CCI, KPZ, SSI, GPC, CVI	Reed	Polyurethane	3	0.3	0.5	10	30	10	30	Protected against polarity reversal	R412022869
PRA, PRE, CCI, KPZ, SSI, GPC, CVI	Reed	Polyurethane	5	0.3	0.5	10	30	10	30	Protected against polarity reversal	R412022870
PRA, PRE, CCI, KPZ, SSI, GPC, CVI	Reed	Polyurethane	10	0.3	0.5	10	30	10	30	Protected against polarity reversal	R412022871
PRA, PRE, CCI, KPZ, SSI, GPC, CVI	electron PNP	Polyurethane	3	0.13		10	30			short circuit resistant, Protected against polarity reversal	R412022853
PRA, PRE, CCI, KPZ, SSI, GPC, CVI	electron PNP	Polyurethane	5	0.13		10	30			short circuit resistant, Protected against polarity reversal	R412022855

Direct mounting for series	Type of contact	Cable sheath	Cable length L [m]	Max. DC switching current [A]	Max. AC switching current [A]	Min. operating voltage DC [V DC]	Max. operating voltage DC [V DC]	Min. operating voltage AC [V AC]	Max. operational voltage AC [V AC]	Version	Part No.
PRA, PRE, CCI, KPZ, SSI, GPC, CVI	electronic PNP	Polyurethane	10	0.13		10	30			short circuit resistant, Protected against polarity reversal	R412022857
PRA, PRE, CCI, KPZ, SSI, GPC, CVI	NPN	Polyurethane	3	0.13		10	30			short circuit resistant, Protected against polarity reversal	R412022849
PRA, PRE, CCI, KPZ, SSI, GPC, CVI	NPN	Polyurethane	5	0.13		10	30			short circuit resistant, Protected against polarity reversal	R412022850

Dimensions

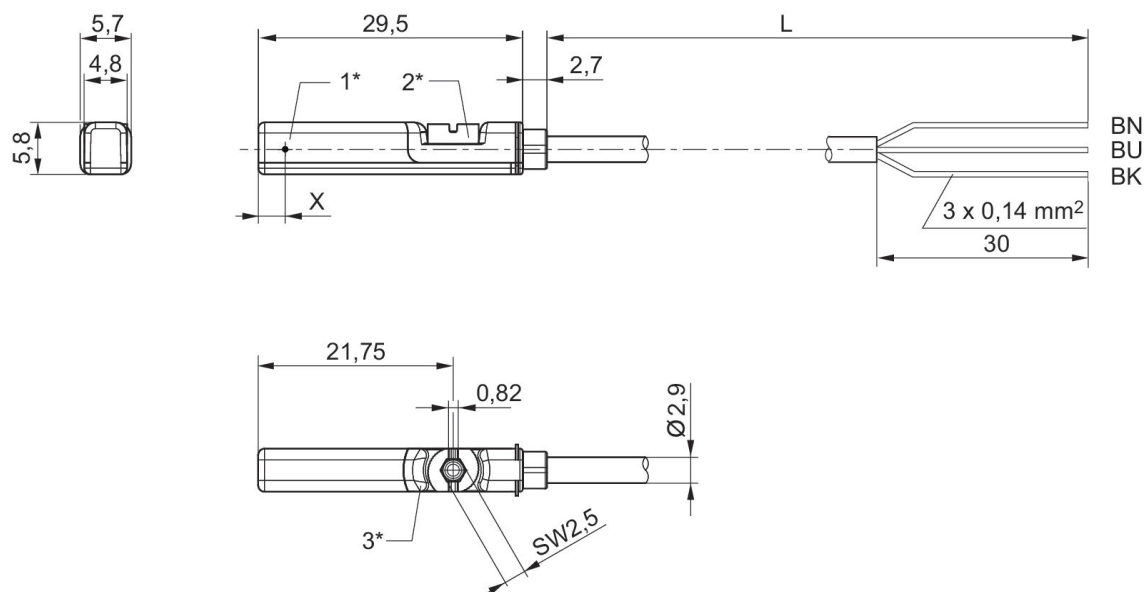

1* = switching point 2* = locking screw 3* = LED window, transparent
L = cable length BN = brown, BK = black, BU = blue
X = electronic: 11.6 mm

R412022866, R412027170

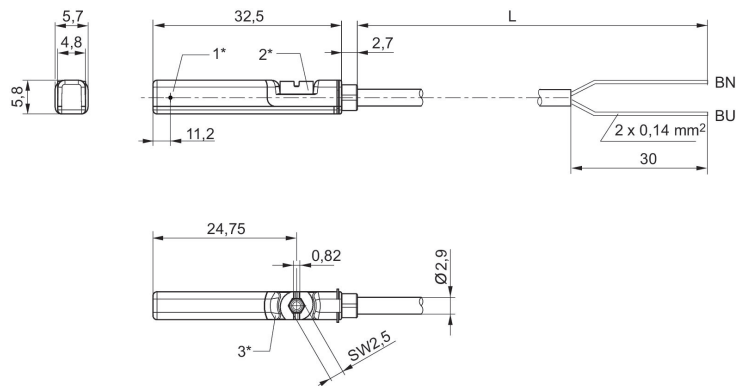

1* = switching point 2* = locking screw 3* = LED window, transparent
L = cable length BN=brown, BU=blue

Sensor, Series ST6

PRA
PRE
CCI
KPZ
SSI
GPC
CVI
open cable ends
ATEX
CE declaration of conformity
cULus
RoHS
UL (Underwriters Laboratories)

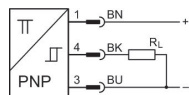

Direct mounting for series	Type of contact	Cable sheath	Cable length L [m]	Max. DC switching current [A]	Min. operating voltage DC [V DC]	Max. operating voltage DC [V DC]	Version	Part No.
PRA, PRE, CCI, KPZ, SSI, GPC, CVI	PNP	Polyurethane	3	0.1	10	30	short circuit resistant, Protected against polarity reversal	R412022854
PRA, PRE, CCI, KPZ, SSI, GPC, CVI	PNP	Polyurethane	5	0.1	10	30	short circuit resistant, Protected against polarity reversal	R412022856

Dimensions

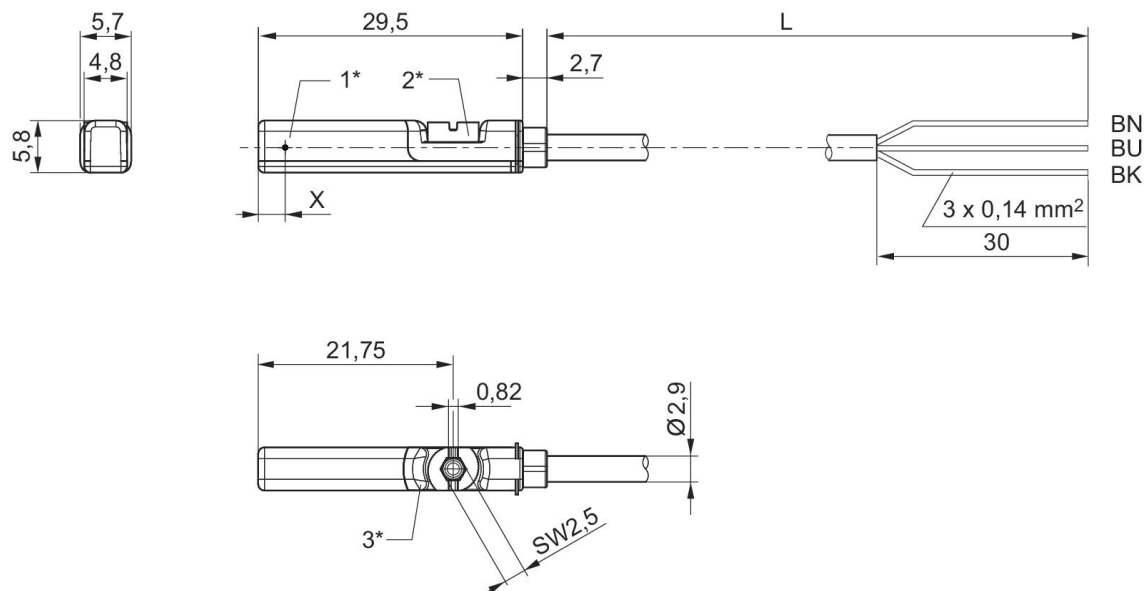

1* = switching point 2* = locking screw 3* = LED window, transparent
L = cable length BN = brown, BK = black, BU = blue
X = electronic: 11.6 mm

Sensors, Series SM6

PRA
PRE
CCI
KPZ
SSI
GPC
CVI
cULus

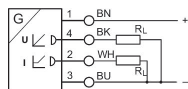

Direct mounting for series	Type of contact	Cable length L [m]	max. measuring range [mm]	Overall length Sensor [mm]	Version	Part No.
PRA, PRE, CCI, KPZ, SSI, GPC, CVI	Analog	2	32	45	short circuit resistant, Protected against polarity reversal, Overload protection	R412010141
PRA, PRE, CCI, KPZ, SSI, GPC, CVI	Analog	2	64	77	short circuit resistant, Protected against polarity reversal, Overload protection	R412010143
PRA, PRE, CCI, KPZ, SSI, GPC, CVI	Analog	2	96	109	short circuit resistant, Protected against polarity reversal, Overload protection	R412010262
PRA, PRE, CCI, KPZ, SSI, GPC, CVI	Analog	2	128	141	short circuit resistant, Protected against polarity reversal, Overload protection	R412010264
PRA, PRE, CCI, KPZ, SSI, GPC, CVI	Analog	2	160	173	short circuit resistant, Protected against polarity reversal, Overload protection	R412010411
PRA, PRE, CCI, KPZ, SSI, GPC, CVI	Analog	2	192	205	short circuit resistant, Protected against polarity reversal, Overload protection	R412010413
PRA, PRE, CCI, KPZ, SSI, GPC, CVI	Analog	2	224	237	short circuit resistant, Protected against polarity reversal, Overload protection	R412010415
PRA, PRE, CCI, KPZ, SSI, GPC, CVI	Analog	2	256	269	short circuit resistant, Protected against polarity reversal, Overload protection	R412010417

Dimensions

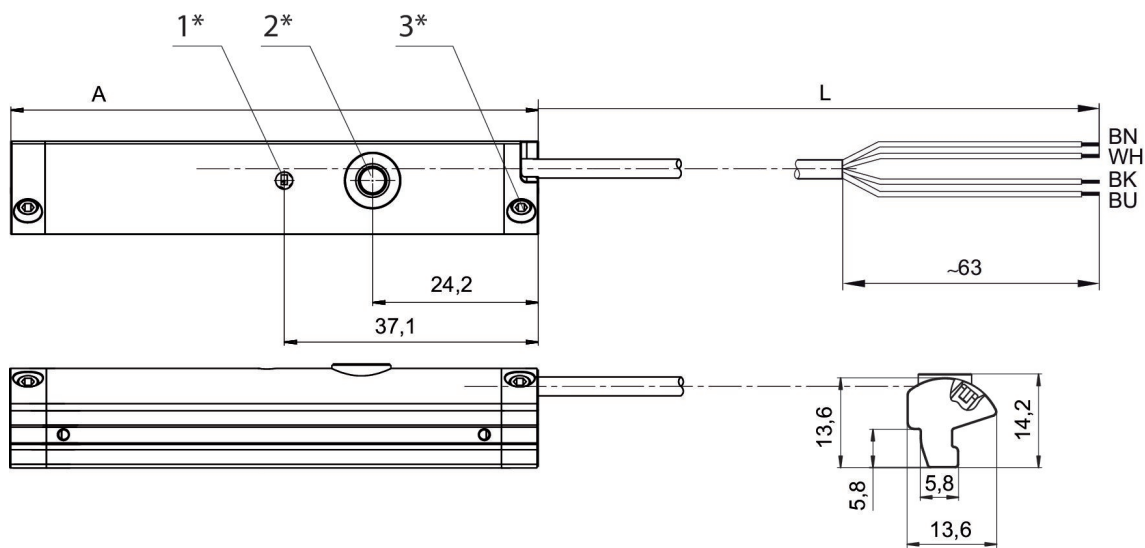

1* = LED 2* = teach button 3* = threaded pin M3x11
 L = cable length
 (2) WH=white
 A = sensor length

Sensors, Series SM6

PRA
PRE
CCI
KPZ
SSI
GPC
CVI
Plug
M8x1
cULus

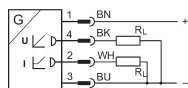

Direct mounting for series	Type of contact	Cable length L [m]	max. measuring range [mm]	Overall length Sensor [mm]	Version	Part No.
PRA, PRE, CCI, KPZ, SSI, GPC, CVI	Analog	0.3	32	45	short circuit resistant, Protected against polarity reversal, Overload protection	R412010142
PRA, PRE, CCI, KPZ, SSI, GPC, CVI	Analog	0.3	64	77	Protected against polarity reversal, Protected against polarity reversal, Overload protection	R412010144
PRA, PRE, CCI, KPZ, SSI, GPC, CVI	Analog	0.3	96	109	Protected against polarity reversal, Protected against polarity reversal, Overload protection	R412010263
PRA, PRE, CCI, KPZ, SSI, GPC, CVI	Analog	0.3	128	141	Protected against polarity reversal, Protected against polarity reversal, Overload protection	R412010265
PRA, PRE, CCI, KPZ, SSI, GPC, CVI	Analog	0.3	160	173	Protected against polarity reversal, Protected against polarity reversal, Overload protection	R412010410
PRA, PRE, CCI, KPZ, SSI, GPC, CVI	Analog	0.3	192	205	Protected against polarity reversal, Protected against polarity reversal, Overload protection	R412010412
PRA, PRE, CCI, KPZ, SSI, GPC, CVI	Analog	0.3	224	237	Protected against polarity reversal, Protected against polarity reversal, Overload protection	R412010414
PRA, PRE, CCI, KPZ, SSI, GPC, CVI	Analog	0.3	256	269	Protected against polarity reversal, Protected against polarity reversal, Overload protection	R412010416

Dimensions

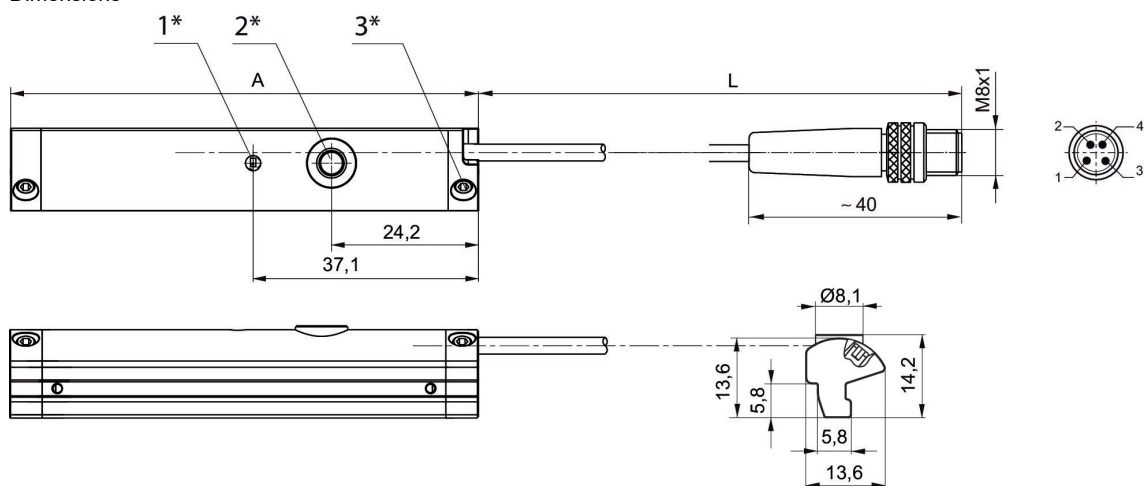

1* = LED 2* = teach button 3* = threaded pin M3x11
 L = cable length
 Pin assignment: 1 = (+), 2 = (OUT 1) 3 = (GND), 4 = (OUT 2), EN 60947-5-7
 A = sensor length

Sensor mounting, Series CB1

ST6
SM6



Max. cylinder Ø [mm]	Material	Part No.
25	Aluminum	R412022357

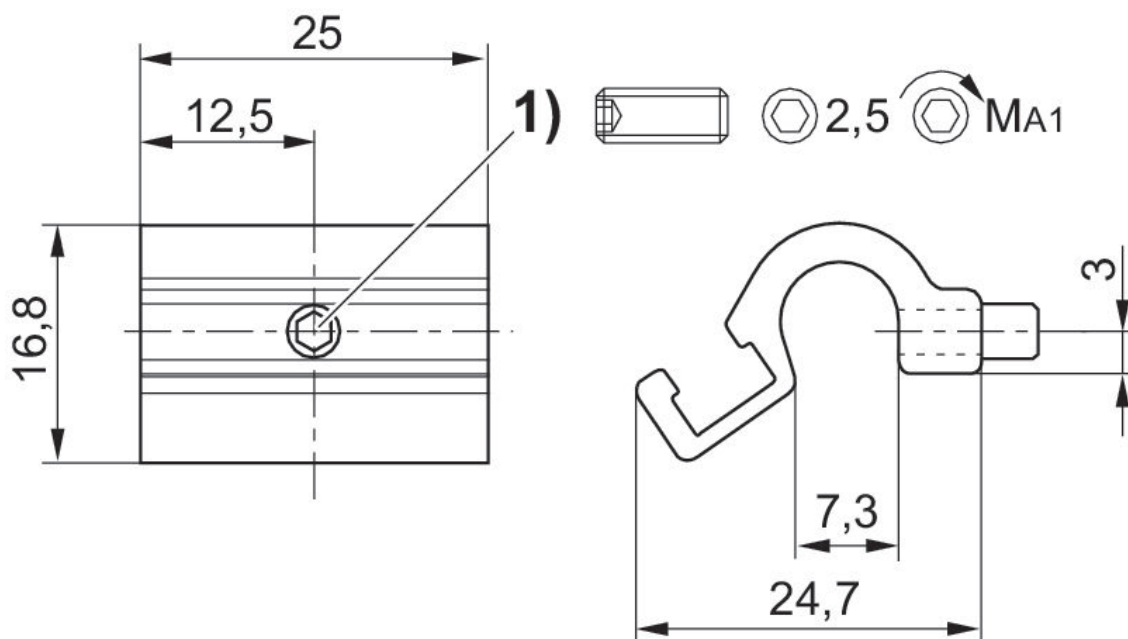

1) Mounting screw

Part No.	Cylinders Ø max.	MA1 [Nm]
R412022357	25 mm	1 + 0,3

Sensor mounting, Series CB1

ST6
SM6



Min. cylinder Ø [mm]	Max. cylinder Ø [mm]	Material	Part No.
32	40	Aluminum	1827020282
50	63	Aluminum	1827020283
80	100	Aluminum	1827020284

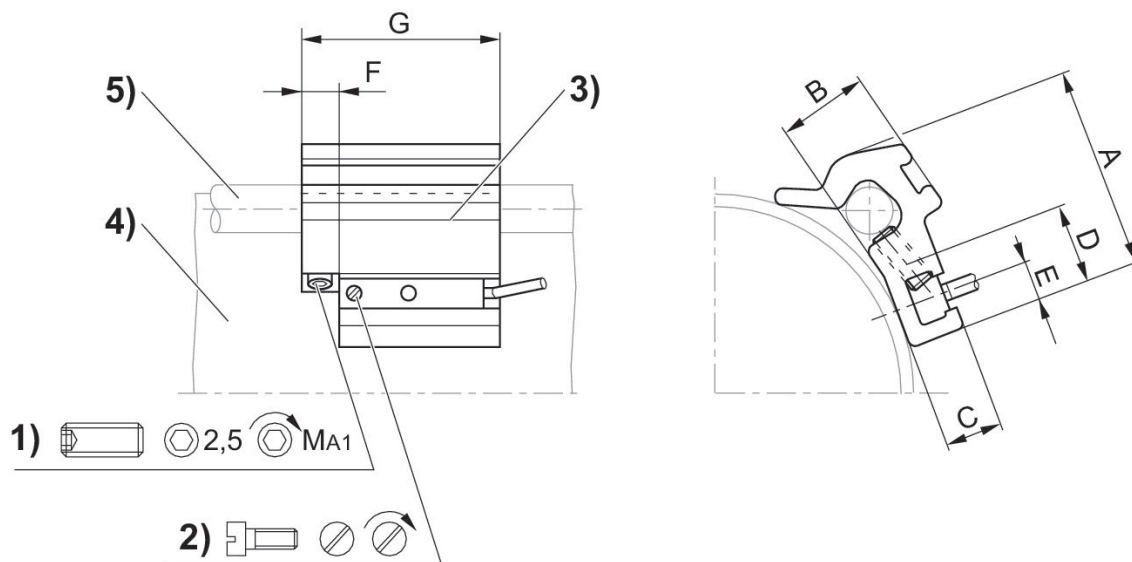

1) Clamping threaded pin 2) Mounting screw for sensor 3) Sensor 4) Cylinder profile 5) Tie rod

Part No.	Cylinders Ø	A	B	C	D	E	F	G	Clamping threaded pin	MA1 [Nm]
1827020282	32 - 40 mm	26	10	7	14	5	8	40	M5x8	2 ±0,2
1827020283	50 - 63 mm	32.5	15.5	7	14	5	8	40	M5x10	2 ±0,2
1827020284	80 - 100 mm	43	17	6.9	14	5	8	40	M5x16	2 ±0,2

Round plug connector, Series CON-RD

Socket
M8x1
3-pin

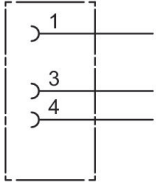

Operational voltage	Contact assignment	Coding	Connection type	Max. current [A]	min. suitable cable Ø [mm]	max. suitable cable Ø [mm]	Part No.
48 V AC/DC	3-pin	A-coded	Soldering	4	3.5	5	1834484173

Dimensions

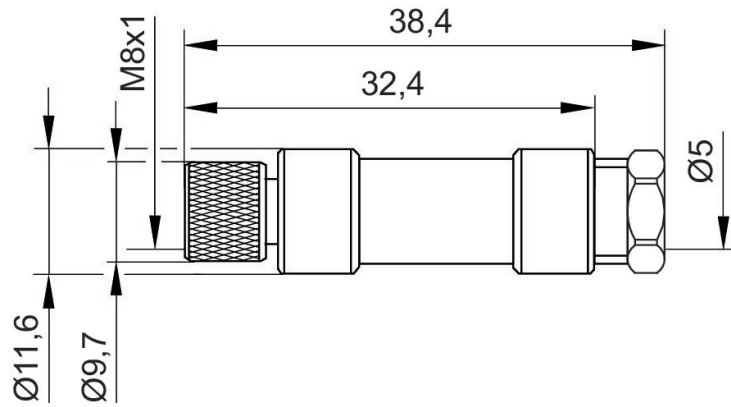

Round plug connector, Series CON-RD

Socket
M8x1
3-pin

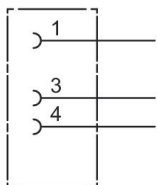

Operational voltage	Contact assignment	Coding	Connection type	Max. current [A]	min. suitable cable Ø [mm]	max. suitable cable Ø [mm]	Part No.
48 V AC/DC	3-pin	A-coded	Soldering	4	3.5	5	1834484174

Dimensions in mm

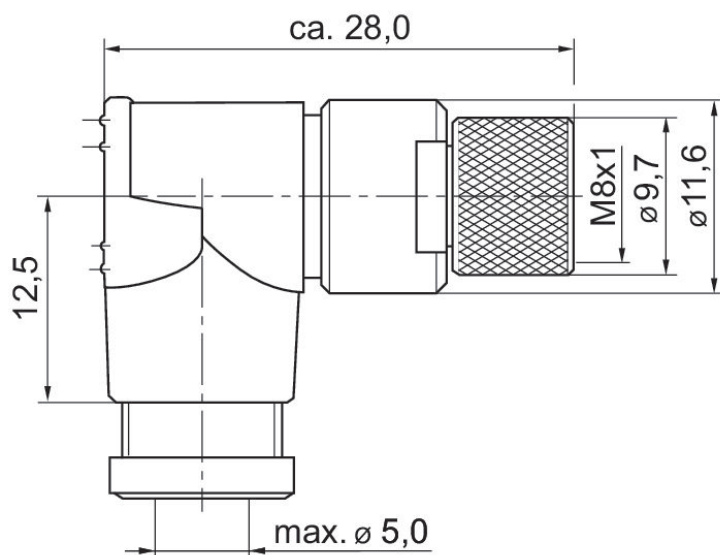

Round plug connector, Series CON-RD

Socket
M8x1
3-pin

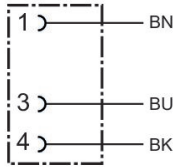

Operational voltage	Current [A]	Electrical connection 1, type	Electrical connection 1, thread size	Electrical connection 1, coding	Electrical connection 2, type	Cable length [m]	Cable-Ø [mm]	Wire cross-section [mm²]	Part No.
48 V AC/DC	4	Socket	M8x1	A-coded	open cable ends	3	4.5	0.24	1834484166
48 V AC/DC	4	Socket	M8x1	A-coded	open cable ends	5	4.5	0.24	1834484168
48 V AC/DC	4	Socket	M8x1	A-coded	open cable ends	10	4.5	0.24	1834484247

Dimensions

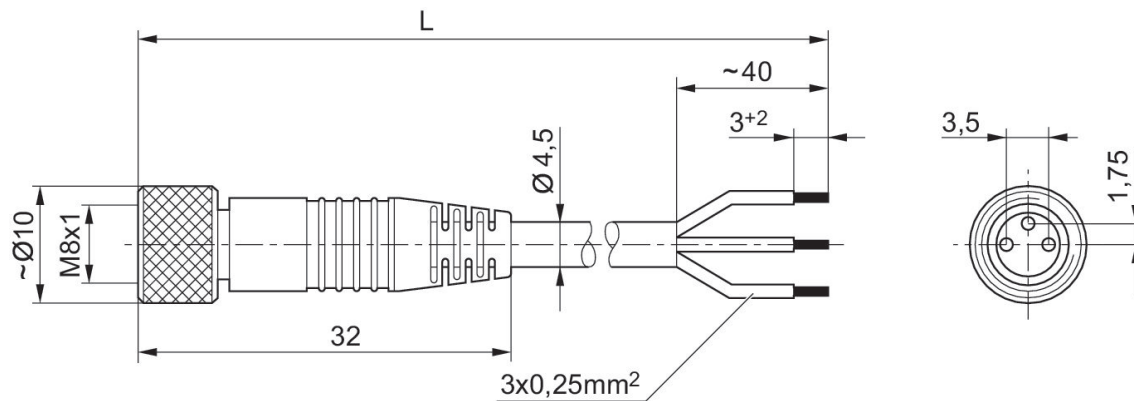

L = length

Round plug connector, Series CON-RD

Socket
M8x1
3-pin

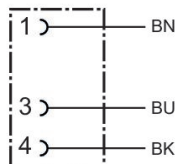

Operational voltage	Current [A]	Electrical connection 1, type	Electrical connection 1, thread size	Electrical connection 1, coding	Electrical connection 2, type	Cable length [m]	Cable-Ø [mm]	Wire cross-section [mm²]	Part No.
48 V AC/DC	4	Socket	M8x1	A-coded	open cable ends	3	4.5	0.24	1834484167
48 V AC/DC	4	Socket	M8x1	A-coded	open cable ends	5	4.5	0.24	1834484169
48 V AC/DC	4	Socket	M8x1	A-coded	open cable ends	10	4.5	0.24	1834484248

Dimensions

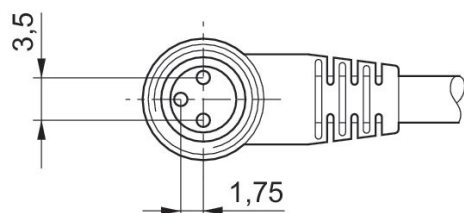
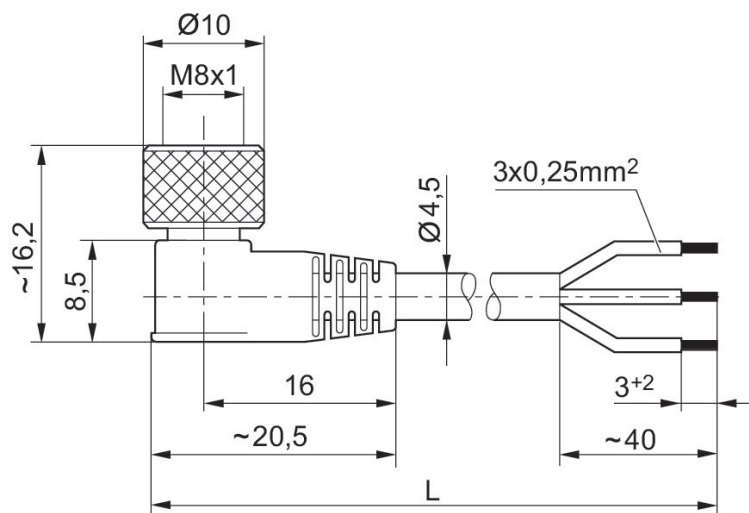

L = length

Silencers, series SI1

External thread
Sintered bronze

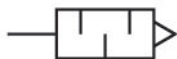

Compressed air connection	Sound pressure level [dB]	Nominal flow [l/min]	Delivery unit [piece]	Weight [kg]	Part No.
G 1/8	75	1623	10	0.01	1827000000
G 1/4	79	3390	10	0.02	1827000001
G 3/8	84	6554	5	0.05	1827000002
G 1/2	90	7223	2	0.08	1827000003

1827000000

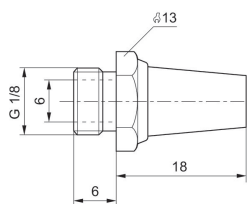

1827000001

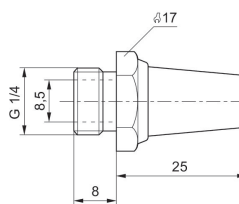

1827000002

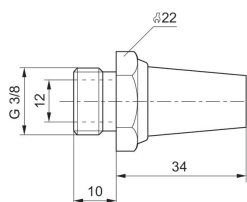

1827000003

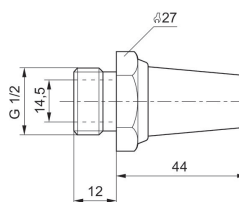

Silencers, series SI1

External thread
Sintered bronze

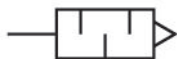

Compressed air connection	Sound pressure level [dB]	Nominal flow [l/min]	Delivery unit [piece]	Weight [kg]	Part No.
G 1/8	85	700	10	0.001	1827000031
G 1/4	88	1116	10	0.01	1827000033
G 3/8	90	1706	5	0.016	1827000034
G 1/2	85	2568	2	0.035	1827000035

Dimensions

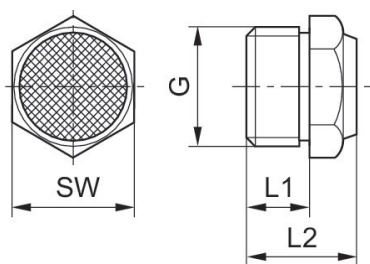

Part No.	Port G	L1	L2	SW
1827000032	M5	5	10.3	7
1827000031	G 1/8	6	11.5	13
1827000033	G 1/4	8	13.5	17
1827000034	G 3/8	10	17.5	22
1827000035	G 1/2	12	19.5	27
8145003400	G 3/4	14	22.5	32
8145001000	G 1	16	22.5	41

Sound pressure level measured at 6 bar at 1 m distance

Efficient pneumatic solutions, our program: cylinders and drives, valves and valve systems, air supply management



Visit us: [Emerson.com/Aventics](https://www.emerson.com/aventics)

Your local contact: [Emerson.com/contactus](https://www.emerson.com/contactus)



[Emerson.com](https://www.emerson.com)



[Facebook.com/EmersonAutomationSolutions](https://www.facebook.com/EmersonAutomationSolutions)



[LinkedIn.com/company/Emerson-Automation-Solutions](https://www.linkedin.com/company/Emerson-Automation-Solutions)



[Twitter.com/EMR_Automation](https://twitter.com/EMR_Automation)

An example configuration is depicted on the title page. The delivered product may thus vary from that in the illustration. Subject to change. This Document, as well as the data, specifications and other information set forth in it, are the exclusive property of AVENTICS GmbH. It may not be reproduced or given to third parties without its consent. Only use the AVENTICS products shown in industrial applications. Read the product documentation completely and carefully before using the product. Observe the applicable regulations and laws of the respective country. When integrating the product into applications, note the system manufacturer's specifications for safe use of the product. The data specified only serve to describe the product. No statements concerning a certain condition or suitability for a certain application can be derived from our information. The information given does not release the user from the obligation of own judgment and verification. It must be remembered that the products are subject to a natural process of wear and aging.

The Emerson logo is a trademark and service mark of Emerson Electric Co. Brand logotype are registered trademarks of one of the Emerson family of companies. All other marks are the property of their respective owners. © 2019 Emerson Electric Co. All rights reserved.



CONSIDER IT SOLVED™