

Série FSG



AVENTICS™

**AVENTICS série FSG Garras de
sucção planas**

EMERSON™

Série FSG

AVENTICS série FSG são copos de sucção planos redondos. Os copos de sucção FSG são a escolha certa para várias aplicações padrão com peças de trabalho niveladas e planas. Copo de sucção redondo de fole com 2,5 dobras, para lidar com peças de trabalho extremamente sensíveis (efeito de amortecimento ideal). Além disso, o design especial das dobras permite o uso em sistemas com tempo de ciclo muito curto.



Visão geral dos produtos

Ventosa plana

Ventosa plana, Série FSG, Ø 1,0 - 3,5.....	4
Ventosa plana, Série FSG, Ø 5,0 - 10,0..... Rosca interna	7
Ventosa plana, Série FSG, Ø 5,0 - 10,0..... Rosca interna Resistente ao calor	9
Ventosa plana, Série FSG, Ø 5,0 - 10,0..... rosca externa	11
Ventosa plana, Série FSG, Ø 5,0 - 10,0..... rosca externa Resistente ao calor	13
Ventosa plana, Série FSG, Ø 15,0 - 150,0..... Rosca interna	15
Ventosa plana, Série FSG, Ø 15,0 - 150,0..... Rosca interna Resistente ao calor	18
Ventosa plana, Série FSG, Ø 15,0 - 95,0..... rosca externa	21
Ventosa plana, Série FSG, Ø 15,0 - 95,0..... rosca externa Resistente ao calor	23
Ventosa plana, Série FSG, Ø 15,0 - 95,0..... Rosca interna com pouco desgaste	26
Ventosa plana, Série FSG, Ø 15,0 - 95,0..... rosca externa com pouco desgaste	28

Ventosa plana, Série FSG, Ø 1,0 - 3,5

Temperatura ambiente mín./máx.: -10 °C ... 70 °C



Diâmetro externo [mm]	Força de retenção [N]	Volume [cm³]	Unidade de fornecimento [Peça]	Peso [kg]	N° de material
1	0.03	0.001	5	0.001	1820455105
1.5	0.06	0.001	5	0.001	1820455106
2	0.12	0.001	5	0.001	1820455107
3.5	0.42	0.002	5	0.001	1820455108

Dimensões

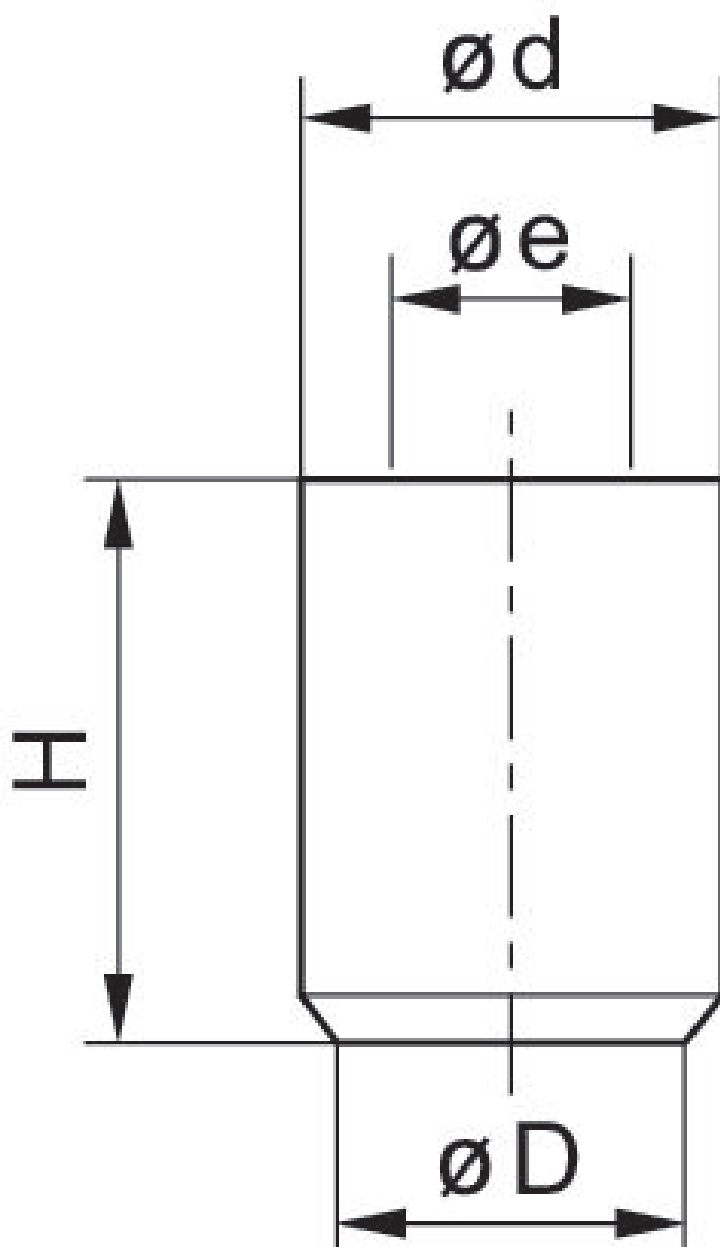

N° de material	$\varnothing D$	$\varnothing e$	$\varnothing d$	H
1820455105	1	0.8	1.2	1.6
1820455106	1.5	1.2	1.8	2.5

N° de material	$\varnothing D$	$\varnothing e$	$\varnothing d$	Ha*)	H
1820455107	2	2	4	3.5	4
1820455108	3.5	2	4	3.5	4

*) altura com funcionamento a vácuo

Curvatura máx. do objeto R min

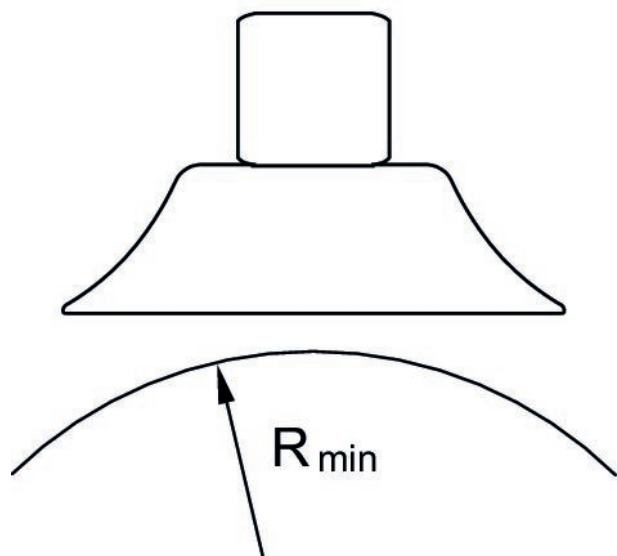

Ventosa plana, Série FSG, Ø 5,0 - 10,0

Tipo de conexão de ar comprimido: Rosca interna
Temperatura ambiente mín./máx.: -10 °C ... 70 °C



Conexão de ar comprimido	Diâmetro externo [mm]	Força de retenção [N]	Volume [cm³]	Unidade de fornecimento [Peça]	Peso [kg]	N° de material
M5	5	0.75	0.005	2	0.0014	1820455049
M5	6	1.2	0.008	2	0.0014	1820455053
M5	8	2.3	0.03	2	0.0015	1820455057
G 1/8	10	4	0.07	2	0.0016	1820455061

Dimensões

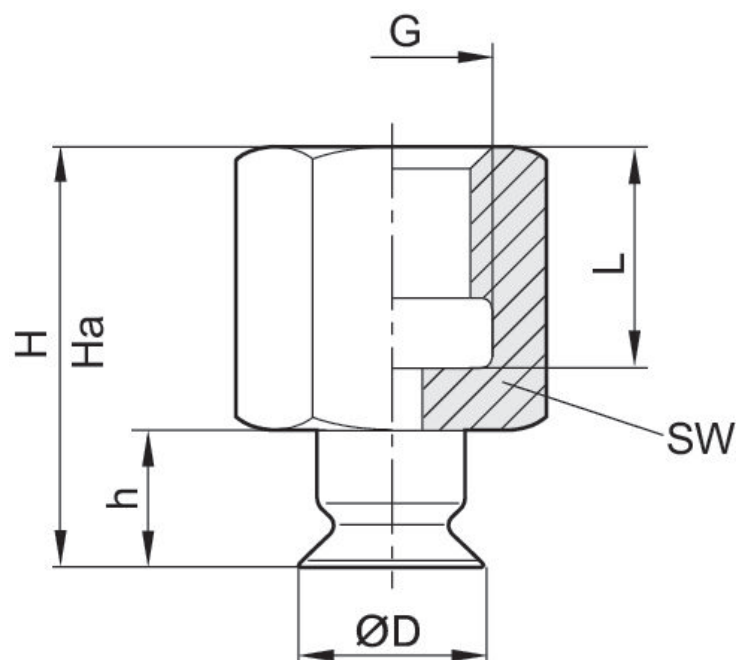

N° de material	ØD	G	Ha*)	H	h	L	SW
1820455049	5	M5	15.6	16.5	6.5	8.5	8
1820455053	6	M5	15.5	16.5	6.5	8.8	8
1820455057	8	M5	15.6	17	7	8.5	8
1820455061	10	G 1/8	22.2	23.5	7.5	13	14

*) altura com funcionamento a vácuo

Curvatura máx. do objeto R min

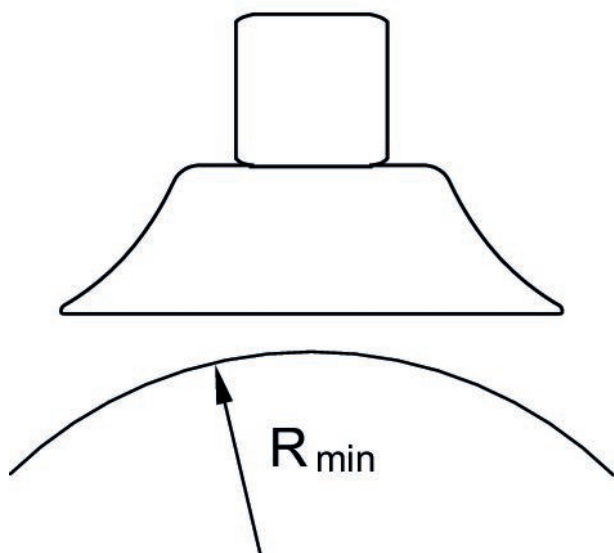

Ventosa plana, Série FSG, Ø 5,0 - 10,0

Tipo de conexão de ar comprimido: Rosca interna
Resistência à temperatura: Resistente ao calor
Temperatura ambiente mín./máx.: -30 °C ... 180 °C



Conexão de ar comprimido	Diâmetro externo [mm]	Força de retenção [N]	Volume [cm³]	Unidade de fornecimento [Peça]	Peso [kg]	Nº de material
M5	5	0.75	0.005	2	0.0014	1820455051
M5	6	1.2	0.008	2	0.0014	1820455055
M5	8	2.3	0.03	2	0.0015	1820455059
G 1/8	10	4	0.07	2	0.0016	1820455063

Dimensões

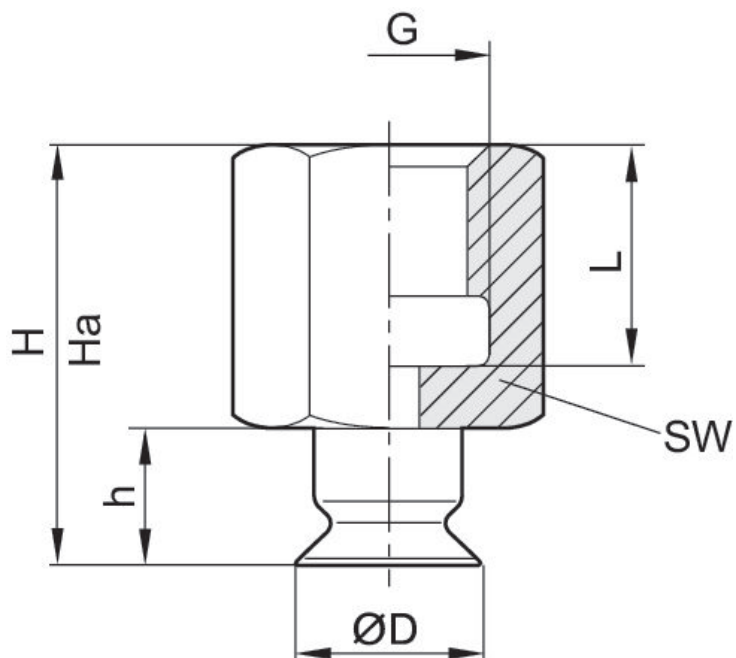

N° de material	ØD	G	Ha*)	H	h	L	SW
1820455051	5	M5	15.6	16.5	6.5	8.5	8
1820455055	6	M5	15.5	16.5	6.5	8.5	8
1820455059	8	M5	15.6	17	7	8.5	8
1820455063	10	G 1/8	22.2	23.5	7.5	13	14

*) altura com funcionamento a vácuo

Curvatura máx. do objeto R min

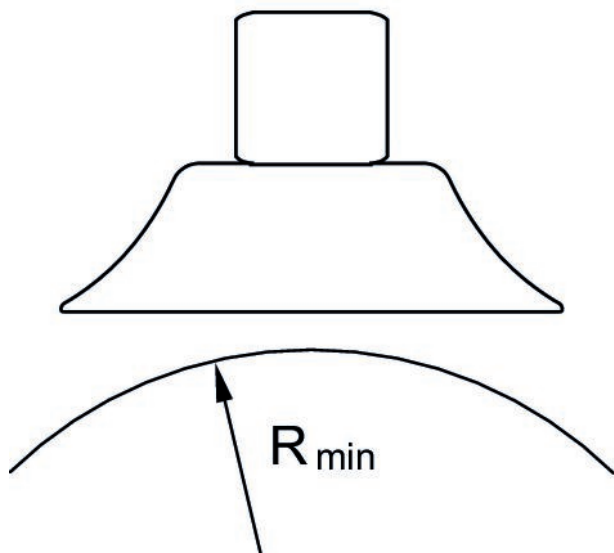

Ventosa plana, Série FSG, Ø 5,0 - 10,0

Tipo de conexão de ar comprimido: rosca externa
Temperatura ambiente mín./máx.: -10 °C ... 70 °C



Conexão de ar comprimido	Diâmetro externo [mm]	Força de retenção [N]	Volume [cm³]	Unidade de fornecimento [Peça]	Peso [kg]	N° de material
M5	5	0.75	0.005	2	0.0014	1820455050
M5	6	1.2	0.008	2	0.0014	1820455054
M5	8	2.3	0.03	2	0.0015	1820455058
G 1/8	10	4	0.07	2	0.0016	1820455062

Dimensões

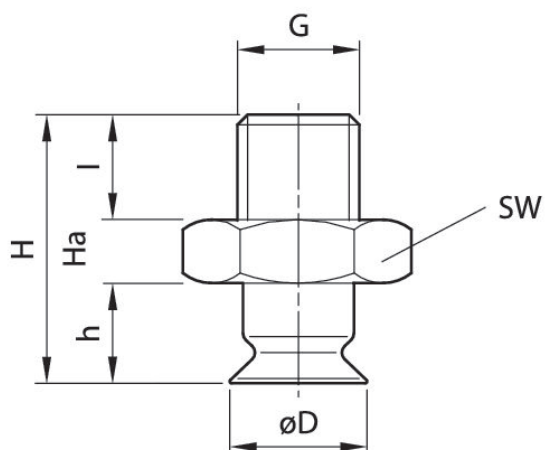

Nº de material	ØD	G	Ha*)	H	h	SW	I
1820455050	5	M5	15.1	16	6.5	8	4.5
1820455054	6	M5	15	16	6.5	8	4.5
1820455058	8	M5	15.1	16.5	7	8	4.5
1820455062	10	G 1/8	19.2	20.5	7.5	14	8

*) altura com funcionamento a vácuo

Curvatura máx. do objeto R min

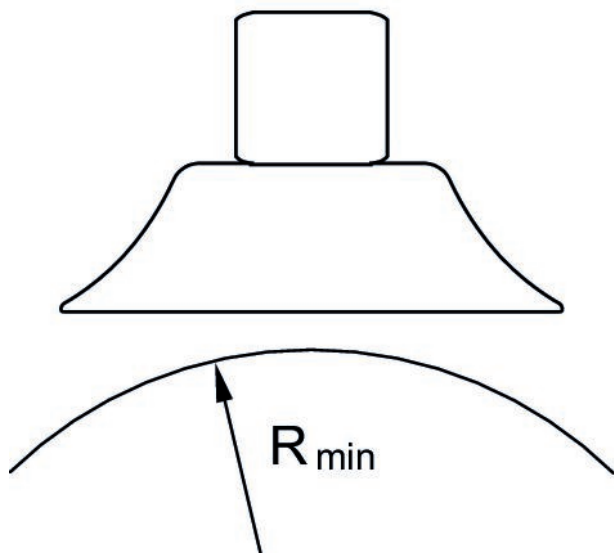

Ventosa plana, Série FSG, Ø 5,0 - 10,0

Tipo de conexão de ar comprimido: rosca externa
Resistência à temperatura: Resistente ao calor
Temperatura ambiente mín./máx.: -30 °C ... 180 °C

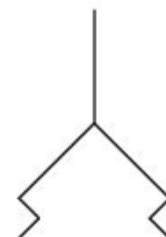

Conexão de ar comprimido	Diâmetro externo [mm]	Força de retenção [N]	Volume [cm³]	Unidade de fornecimento [Peça]	Peso [kg]	Nº de material
M5	5	0.75	0.005	2	0.0014	1820455052
M5	6	1.2	0.008	2	0.0014	1820455056
M5	8	2.3	0.03	2	0.0015	1820455060
G 1/8	10	4	0.07	2	0.0016	1820455064

Dimensões

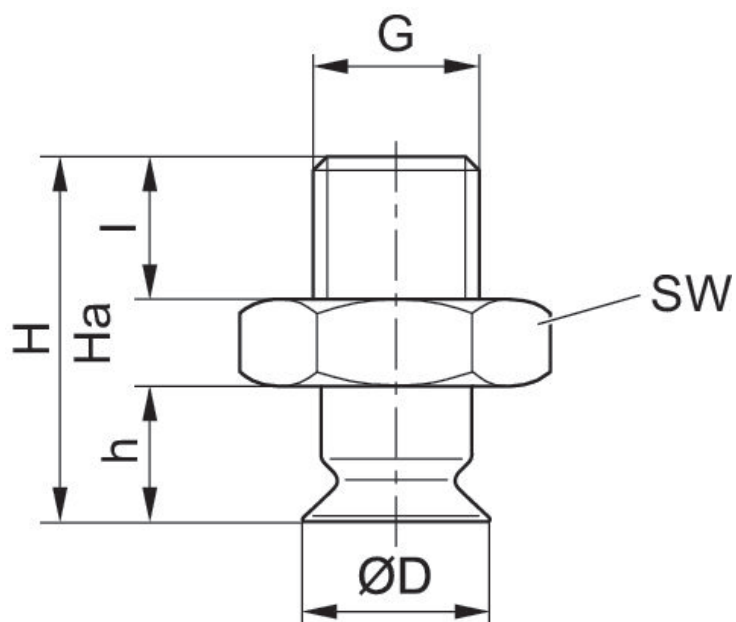

N° de material	ØD	G	Ha*)	H	h	SW	I
1820455052	5	M5	15.1	16	6.5	8	4.5
1820455056	6	M5	15	16	6.5	8	4.5
1820455060	8	M5	15.1	16.5	7	8	4.5
1820455064	10	G 1/8	19.2	20.5	7.5	14	8

*) altura com funcionamento a vácuo

Curvatura máx. do objeto R min

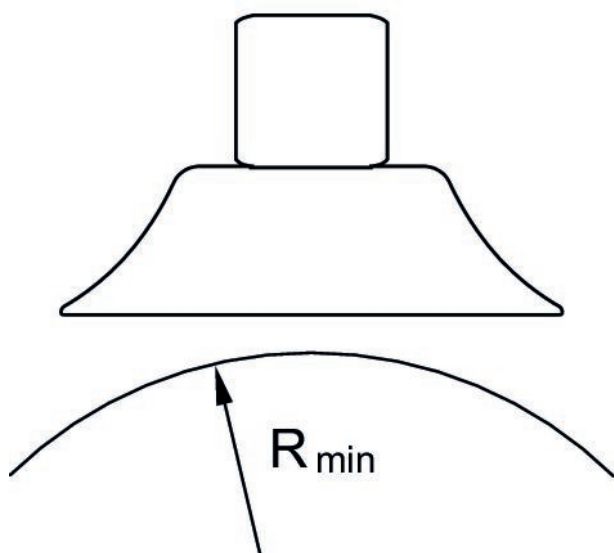

Ventosa plana, Série FSG, Ø 15,0 - 150,0

Tipo de conexão de ar comprimido: Rosca interna
Temperatura ambiente mín./máx.: -10 °C ... 70 °C



Conexão de ar comprimido	Diâmetro externo [mm]	Força de retenção [N]	Volume [cm³]	Unidade de fornecimento [Peça]	Peso [kg]	N° de material
G 1/8	15	9	0.4	2	0.0045	1820455065
G 1/8	20	15.5	0.8	1	0.0056	1820455069
G 1/8	25	26.5	1.3	1	0.0085	1820455073
G 1/8	28.8	34	1.3	1	0.0092	1820455077
G 1/8	35	44	2.7	1	0.0119	1820455081
G 1/8	40	57.7	3.8	1	0.0135	1820455085
G 1/8	50	91	7	1	0.0173	1820455089
G 1/4	60	125	10	1	0.0369	1820455093
G 1/4	80	260	25	1	0.0652	1820455097
G 1/4	95	350	35	1	0.1049	1820455101
G 1/2	120	540	77.8	1	0.3526	1820415165
G 1/2	147.5	842	176.3	1	0.5214	1820415167

Dimensões

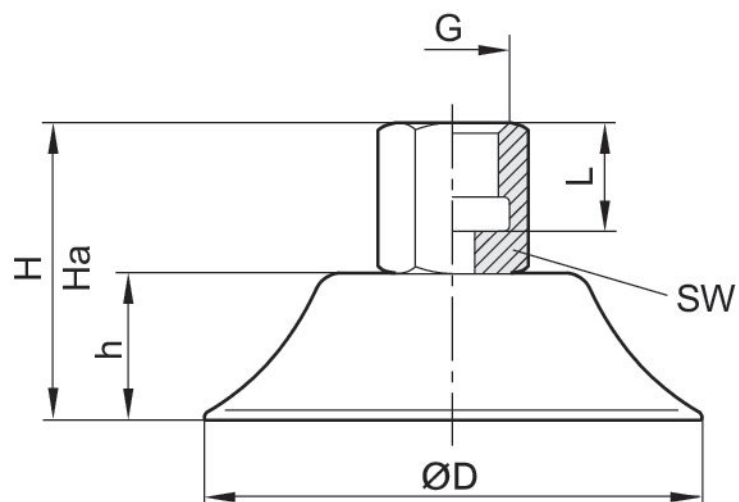

Nº de material	ØD	G	H_{a^*}	H	h	L	SW
1820455065	15	G 1/8	22.1	24	8	13	14
1820455069	20	G 1/8	23.7	26	10	13	14
1820455073	25	G 1/8	27	30	14	13	14
1820455077	28.8	G 1/8	26	28	12	13	14
1820455081	35	G 1/8	27	30	14	13	14
1820455085	40	G 1/8	26.5	30	14	13	14
1820455089	50	G 1/8	27	31	15	13	14
1820455093	60	G 1/4	34	39	18.5	11	17
1820455097	80	G 1/4	37	41	20.5	11	17
1820455101	95	G 1/4	35.5	41.5	21.5	11	17
1820415165	120	G 1/2	30.5	36.5	23.5	13	-
1820415167	147.5	G 1/2	36.5	45.5	31	13	-

*) altura com funcionamento a vácuo

Curvatura máx. do objeto R min

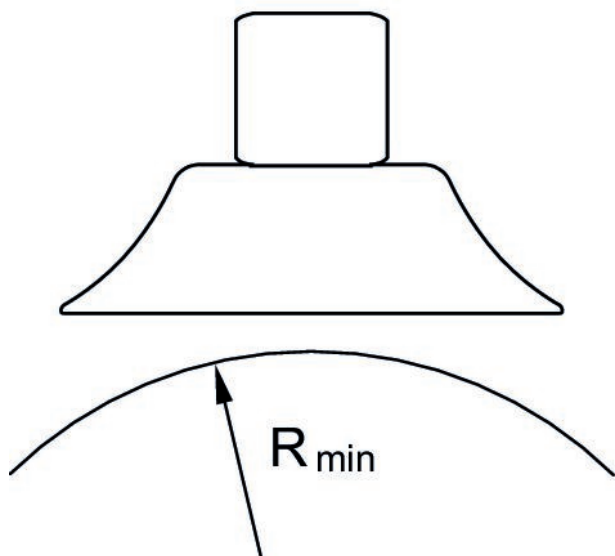

Ventosa plana, Série FSG, Ø 15,0 - 150,0

Tipo de conexão de ar comprimido: Rosca interna
Resistência à temperatura: Resistente ao calor
Temperatura ambiente mín./máx.: -30 °C ... 180 °C

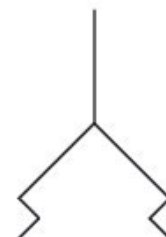

Conexão de ar comprimido	Diâmetro externo [mm]	Força de retenção [N]	Volume [cm³]	Unidade de fornecimento [Peça]	Peso [kg]	N° de material
G 1/8	15	9	0.008	2	0.0045	1820455067
G 1/8	20	15.5	0.03	1	0.0056	1820455071
G 1/8	25	26.5	0.07	1	0.0085	1820455075
G 1/8	28.8	34	0.4	1	0.0092	1820455079
G 1/8	35	44	0.8	1	0.0119	1820455083
G 1/8	40	57.7	1.3	1	0.0135	1820455087
G 1/8	50	91	1.3	1	0.0173	1820455091
G 1/4	60	125	2.7	1	0.0369	1820455095
G 1/4	80	260	3.8	1	0.0652	1820455099
G 1/4	95	350	7	1	0.1049	1820455103
G 1/2	120	540	10	1	0.3526	1820415164
G 1/2	147.5	842	25	1	0.5214	1820415166

Dimensões

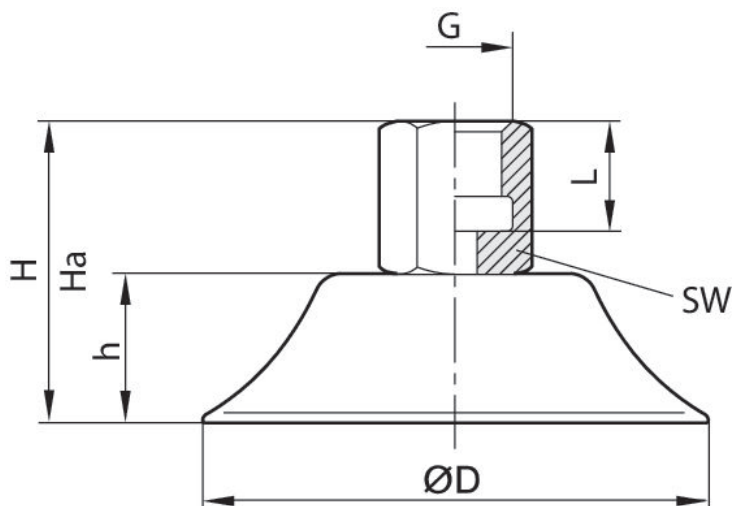

N° de material	Ø D	G	Ha*)	H	h	L	SW
1820455067	15	G 1/8	22.1	24	8	13	14
1820455071	20	G 1/8	23.7	26	10	13	14
1820455075	25	G 1/8	27	30	14	13	14
1820455079	28.8	G 1/8	26	28	12	13	14
1820455083	35	G 1/8	27	30	14	13	14
1820455087	40	G 1/8	26.5	30	14	13	14
1820455091	50	G 1/8	27	31	15	13	14
1820455095	60	G 1/4	34	39	18.5	11	17
1820455099	80	G 1/4	35	41	20.5	11	17
1820455103	95	G 1/4	35.5	41.5	21.5	11	17
1820415164	120	G 1/2	30.5	36.5	23.5	13	-
1820415166	147.5	G 1/2	36.5	45.5	31	13	-

*) altura com funcionamento a vácuo

Curvatura máx. do objeto R min

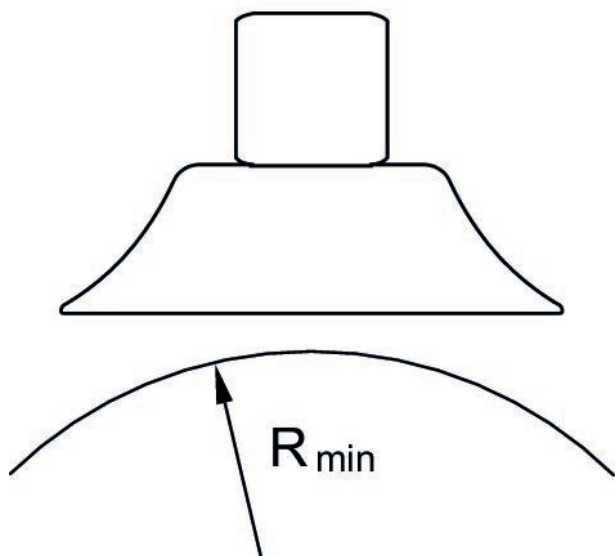

Ventosa plana, Série FSG, Ø 15,0 - 95,0

Tipo de conexão de ar comprimido: rosca externa
Temperatura ambiente mín./máx.: -10 °C ... 70 °C

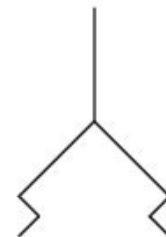

Conexão de ar comprimido	Diâmetro externo [mm]	Força de retenção [N]	Volume [cm³]	Unidade de fornecimento [Peça]	Peso [kg]	N° de material
G 1/8	15	9	0.4	2	0.0058	1820455066
G 1/8	20	15.5	0.8	1	0.007	1820455070
G 1/8	25	26.5	1.3	1	0.0072	1820455074
G 1/8	28.8	34	1.3	1	0.0079	1820455078
G 1/8	35	44	2.7	1	0.0106	1820455082
G 1/8	40	57.7	3.8	1	0.0122	1820455086
G 1/8	50	91	7	1	0.0153	1820455090
G 1/4	60	125	10	1	0.0342	1820455094
G 1/4	80	260	25	1	0.0625	1820455098
G 1/4	95	350	35	1	0.1022	1820455102

Dimensões

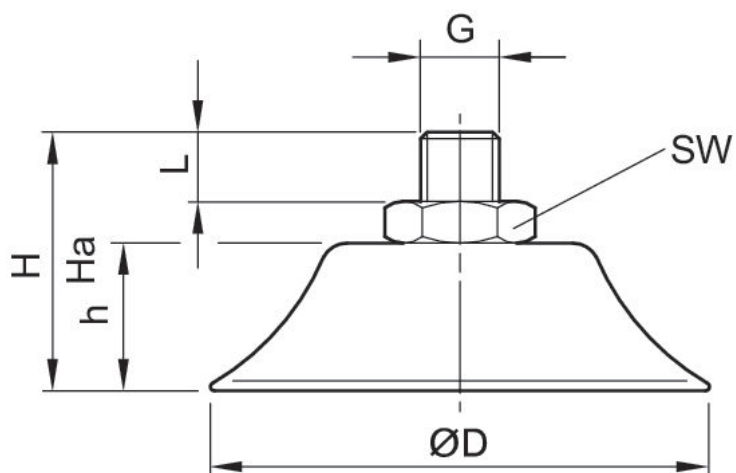

N° de material	ØD	G	Ha*)	H	h	L	SW
1820455066	15	G 1/8	19.1	21	8	8	14
1820455070	20	G 1/8	20.7	23	10	8	14
1820455074	25	G 1/8	24	27	14	8	14
1820455078	28.8	G 1/8	23	25	12	8	14
1820455082	35	G 1/8	24	27	14	8	14
1820455086	40	G 1/8	23.5	27	14	8	14
1820455090	50	G 1/8	24	28	15	8	14
1820455094	60	G 1/4	28	33	18.5	10	17
1820455098	80	G 1/4	29	35	20.5	10	17
1820455102	95	G 1/4	29.5	35.5	21.5	10	17

*) altura com funcionamento a vácuo

Curvatura máx. do objeto R min

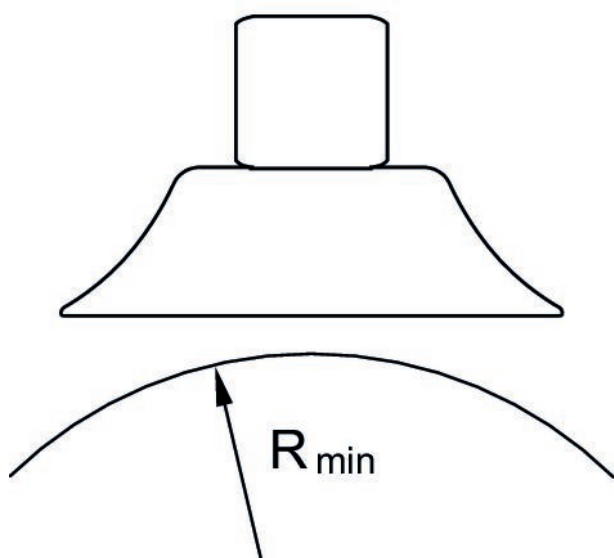

Ventosa plana, Série FSG, Ø 15,0 - 95,0

Tipo de conexão de ar comprimido: rosca externa
Resistência à temperatura: Resistente ao calor
Temperatura ambiente mín./máx.: -30 °C ... 180 °C

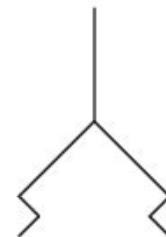

Conexão de ar comprimido	Diâmetro externo [mm]	Força de retenção [N]	Volume [cm³]	Unidade de fornecimento [Peça]	Peso [kg]	N° de material
G 1/8	15	9	0.4	2	0.0058	1820455068
G 1/8	20	15.5	0.8	1	0.007	1820455072
G 1/8	25	26.5	1.3	1	0.0072	1820455076
G 1/8	28.8	34	1.3	1	0.0079	1820455080
G 1/8	35	44	2.7	1	0.0106	1820455084
G 1/8	40	57.7	3.8	1	0.0122	1820455088
G 1/8	50	91	7	1	0.0153	1820455092
G 1/4	60	125	10	1	0.0342	1820455096
G 1/4	80	260	25	1	0.0625	1820455100
G 1/4	95	350	35	1	0.1022	1820455104

Dimensões

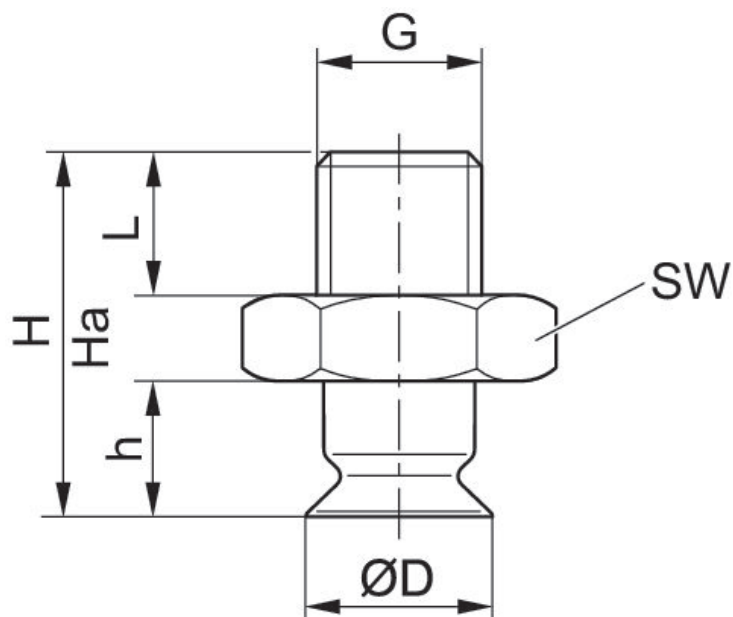

N° de material	ØD	G	Ha*)	H	h	L	SW
1820455068	15	G 1/8	19.1	21	8	8	14
1820455072	20	G 1/8	20.7	23	10	8	14
1820455076	25	G 1/8	24	27	14	8	14
1820455080	28.8	G 1/8	23	25	12	8	14
1820455084	35	G 1/8	24	27	14	8	14
1820455088	40	G 1/8	23.5	27	14	8	14
1820455092	50	G 1/8	24	28	15	8	14
1820455096	60	G 1/4	28	33	18.5	10	17
1820455100	80	G 1/4	29	35	20.5	10	17
1820455104	95	G 1/4	29.5	35.5	21.5	10	17

*) altura com funcionamento a vácuo

Curvatura máx. do objeto R min

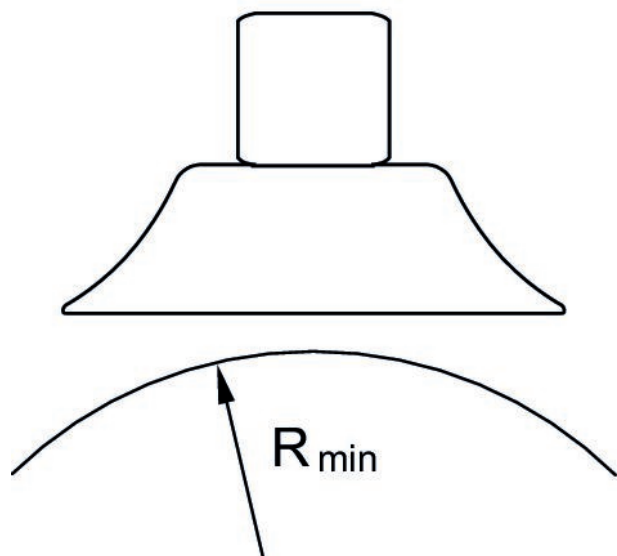

Ventosa plana, Série FSG, Ø 15,0 - 95,0

Tipo de conexão de ar comprimido: Rosca interna
 Temperatura ambiente mín./máx.: -40 °C ... 80 °C



Conexão de ar comprimido	Diâmetro externo [mm]	Força de retenção [N]	Volume [cm³]	Unidade de fornecimento [Peça]	Peso [kg]	N° de material
G 1/8	14.5	8.5	0.5	1	0.0077	1820415153
G 1/8	30	32	1.7	1	0.008	1820415154
G 1/4	50	95	6	1	0.0142	1820415155
G 1/4	60	130	15	1	0.0204	1820415172
G 1/4	80	260	30	1	0.0521	1820415156
G 1/4	95	350	42	1	0.0777	1820415157

Dimensões

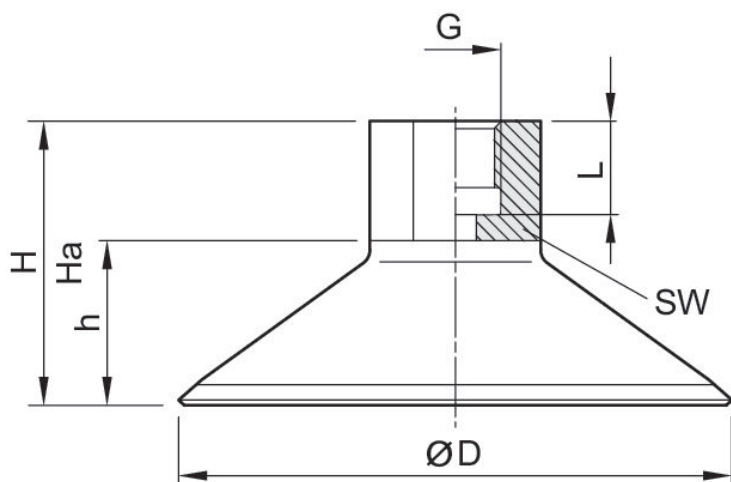

N° de material	ØD	G	H	Ha*)	h	L	SW
1820415153	14.5	G 1/8	25.5	24	9.5	9	14
1820415154	30	G 1/8	29	26	13	9	14
1820415155	50	G 1/4	32	27.5	17	12	17
1820415172	60	G 1/4	33.5	27.5	18.5	12	17
1820415156	80	G 1/4	40	34	25	12	22
1820415157	95	G 1/4	40	34	25	12	22

*) altura com funcionamento a vácuo

Curvatura máx. do objeto R min

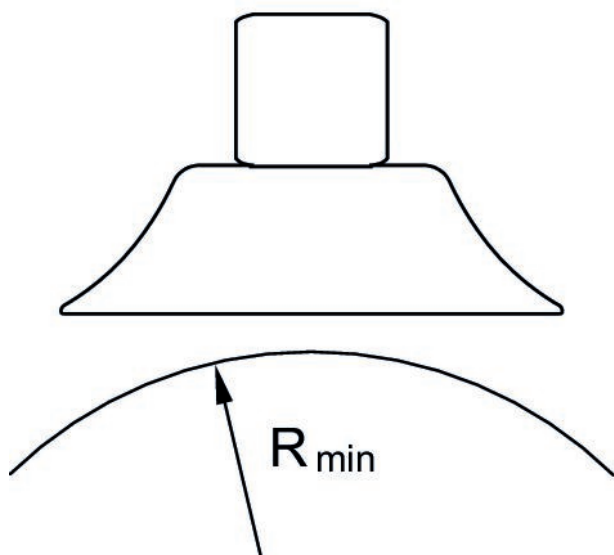

Ventosa plana, Série FSG, Ø 15,0 - 95,0

Tipo de conexão de ar comprimido: rosca externa
Temperatura ambiente mín./máx.: -40 °C ... 80 °C



Conexão de ar comprimido	Diâmetro externo [mm]	Força de retenção [N]	Volume [cm³]	Unidade de fornecimento [Peça]	Peso [kg]	N° de material
G 1/8	14.5	8.5	0.5	1	0.0064	1820455012
G 1/8	30	32	1.7	1	0.0064	1820455013
G 1/4	50	95	6	1	0.0149	1820455015
G 1/4	60	130	15	1	0.0211	1820415173
G 1/4	80	260	30	1	0.0472	1820455018
G 1/4	95	350	42	1	0.0728	1820455111

Dimensões

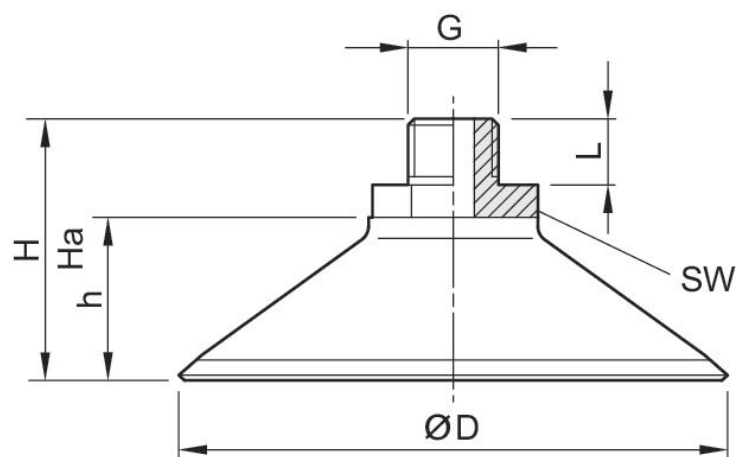

N° de material	ØD	G	H	Ha*)	h	L	SW
1820455012	14.5	G 1/8	22.5	21	9.5	8	14
1820455013	30	G 1/8	26	23	13	8	14
1820455015	50	G 1/4	32	27.5	17	10	17
1820415173	60	G 1/4	33.5	27.5	18.5	10	17
1820455018	80	G 1/4	40	34	25	10	22
1820455111	95	G 1/4	40	34	25	10	22

*) altura com funcionamento a vácuo



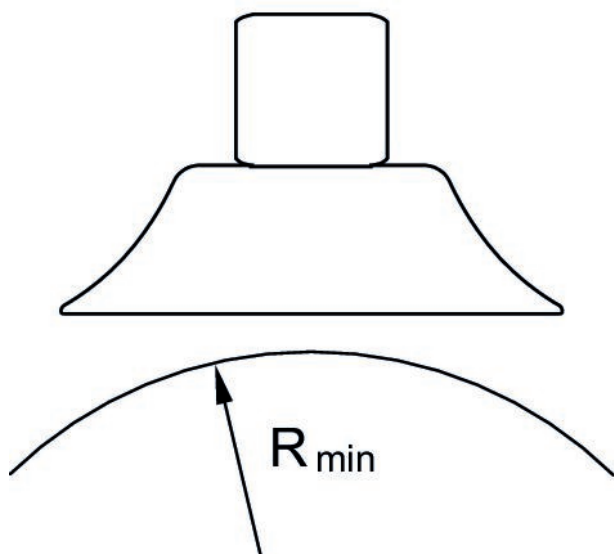

Curvatura máx. do objeto R min



Efficient pneumatic solutions, our program:
cylinders and drives, valves and valve systems,
air supply management, proportional pressure
control valves



Visit us: www.Emerson.com/aventics
Your local contact: Emerson.com/contactus

-  Emerson.com
-  Facebook.com/EmersonAutomationSolutions
-  LinkedIn.com/company/Emerson-Automation-Solutions
-  Twitter.com/EMR_Automation



The Emerson logo is a trademark and service mark of Emerson Electric Co. AVENTICS is a registered trademark of one of the Emerson family of companies. All other trademarks are the property of their respective owners. © 2020 Emerson Electric Co. All rights reserved.



CONSIDER IT SOLVED™