

## 系列 RDC



AVENTICS™

AVENTICS RDC 系列膜片和活塞  
执行机构

  
EMERSON™

## 系列 RDC

安沃驰 RDC 系列挠性隔膜气缸摩擦力低，而且可以在低压状态下驱动。这些气缸可以精确实现力平衡，特别是在微调系统中。

- Ø 52,5 ... 115 mm
- 单作用式，不受压缩回
- 摩擦极低，适合灵敏动力调整



隔膜式和活塞式气缸, 系列 RDC

膜片式气缸  
外螺纹  
内螺纹  
单作用式, 不受压缩回



活塞- Ø [mm]	行程 [mm]	实用原则	伸出运动的活塞力 [N]	活塞杆螺纹	螺纹接口	活塞杆-Ø [mm]	重量 [kg]	物料号
52.5	40	单作用式, 不受压缩回	1363	M10x1,25	G 1/8	12	1.6	5218535110
75	60	单作用式, 不受压缩回	2783	M10x1,25	G 3/8	16	3	5218555110
85	70	单作用式, 不受压缩回	3575	M16x1,5	G 1/4	20	3.6	5218565110
95	75	单作用式, 不受压缩回	4465	M16x1,5	G 3/8	20	4.1	5218575120
115	95	单作用式, 不受压缩回	6543	M16x1,5	G 3/8	20	5.8	5218585120

规格

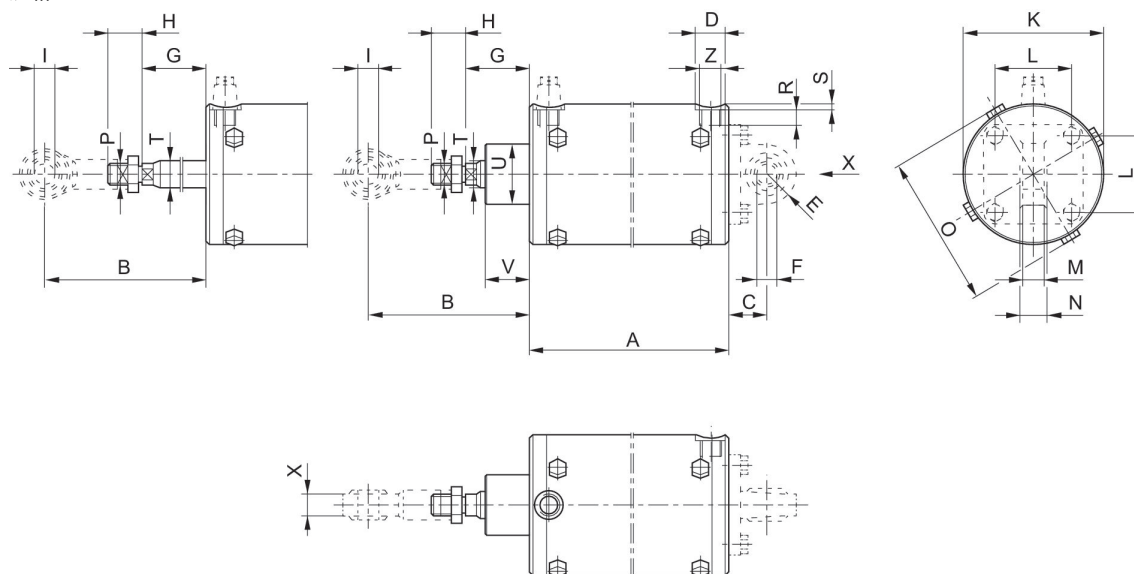

活塞- Ø	A	B	C	D	E	F H7	G	H	I H7	K
52.5	140	67	29	17	15	10	19	26	10	60
75	166	84	26	23	18	12	32	31	10	86
85	202	118	30	22	22	16	43	26	16	97

活塞- Ø	A	B	C	D	E	F H7	G	H	I H7	K
95	208	124	30	23	22	16	49	26	16	106
115	247	120	38	23	25	16	45	26	16	127

活塞- Ø	L	M	N	O	P	R	S	U	V	T h7
52.5	33	7-9	14	68	M10x1,25	8	3.1	-	-	12
75	49	9-11	16	92	M10x1,25	12	3.5	-	-	16
85	59	14,5-17,5	21	108	M16x1,5	12	4.5	-	-	20
95	59	14,5-17,5	21	117	M16x1,5	12	3.5	45	34	20
115	75	14-17,5	21	138	M16x1,5	12	3.6	45	33	20

活塞- Ø	X	Z
52.5	14	G 1/8
75	14	G 3/8
85	21	G 1/4
95	21	G 3/8
115	21	G 3/8

后耳环 MP6, 系列 CM1

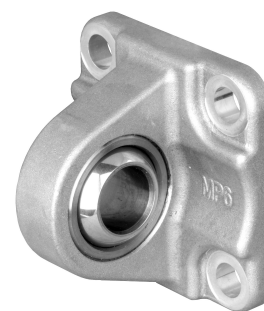

活塞直径 [mm]	万向轴承-Ø [mm]	材料	物料号
52.5	10	铝材	5220163442
75	12	铝材	5220363442
85, 95	16	铝材	5220463442
115	16	铝材	5220563442

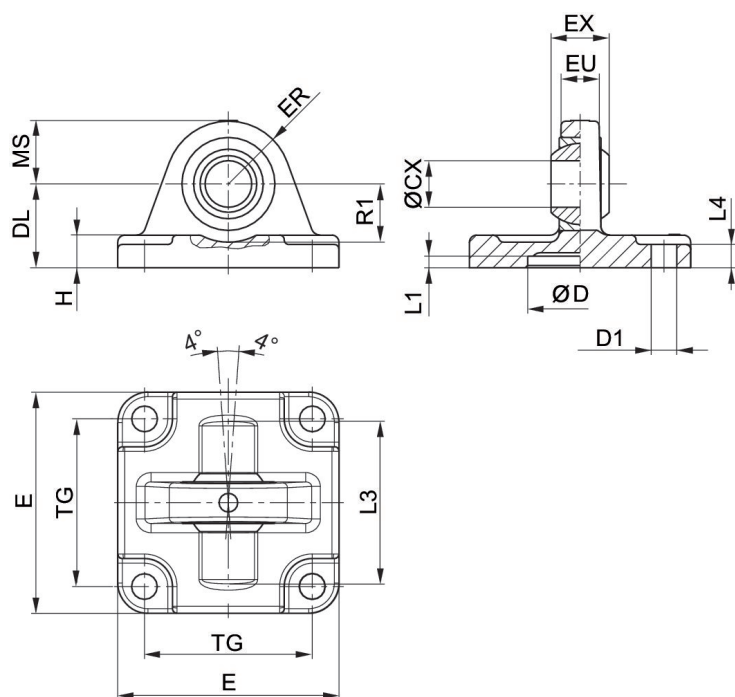

供货内容范围：对接轴承包括固定螺栓

活塞- Ø	物料号	ØCX H7	ØD H11	ØD1 H13	DL ±0,2	E	EX -0,1	ER	EU	H
25	3663602000	10	18	5,5	20	40	9	14	8	6
32	3663603000	10	20	5,5	22	46	9	15	8	6
40	3663604000	12	30	6,6	28	55	12	17	9.5	8
52,5	3663605000	12	40	6,6	28	62	12	17	9.5	9
63	5220163442	10	-	7.5	29	45	14	15	10.5	8

活塞- Ø	物料号	ØCX H7	ØD H11	ØD1 H13	DL ±0,2	E	EX -0,1	ER	EU	H
75	3663606000	16	55	9	36	80	16	25	12,5	11
80	5220363442	12	-	10	26	65	16	18	12	10
80	3663608000	16	70	9	38	94	16	28	12,5	12
85, 95	5220463442	16	-	10	30	75	21	22	15	10
100	3663610000	20	90	11	43	114	20	35	16	15
115	5220563442	16	-	12	37.5	95	21	25	15	12

活塞- Ø	L1 最小	L3	L4	MS -0,5	R1 最小	TG
25	3	-	3	14	-	26
32	0.5	42	6	15	16	32
40	0.5	48	8	17	16	32
52,5	0.5	55	9	17	18	46
63	-	-	-	-	-	33
75	0.5	70	11	25	21	59
80	-	-	-	-	-	49
80	0.5	80	12	28	21	73
85, 95	-	-	-	-	-	59
100	0.5	100	15	35	28	90
115	-	-	-	-	-	75

柔性耦合连接件 PM5 , CM2 系列



螺纹尺寸	材料	物料号
M10x1,25	钢, 镀铬	R412026142
M16x1,5	钢, 镀铬	R412026144

规格

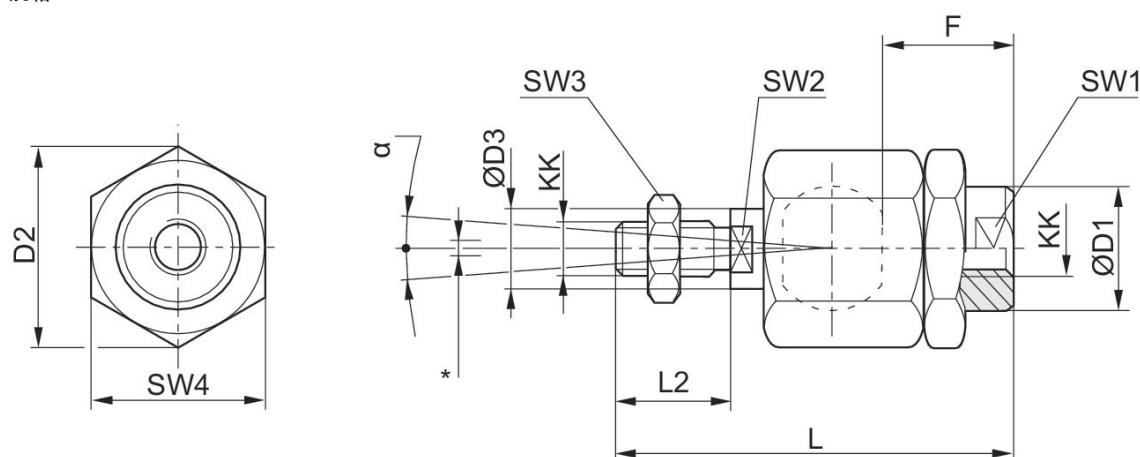

\* 的径向平衡

KK	物料号	Ø D1	D2	Ø D3	F	L ±2	L2	SW1	SW2	SW3
M4	1826409008	12	13.5	4	13	33	8	12	3.2	7
M5	R412007860	8.5	14.8	6	12	38.5	13.5	7	5	8
M6x1	R412026140	8.5	14.5	6	11	36.5	11	7	5	10
M8x1.25	R412026141	12.5	19	8	21	58	21	11	7	13
M10x1.25	R412026142	22	32	14	23	74.5	23	19	12	17
M12x1.25	R412026143	22	32	14	24	75	24	19	12	19
M16x1.5	R412026144	32	45	22	30	103	30	30	20	24
M20x1.5	R412026145	32	45	22	40	119	40	30	20	30
M27x2	1826409006	62	62	28	48	147	54	32	24	41
M36x2	1826409007	80	80	38	86	241	72	50	36	55
M42x2	R412007729	64	98	42	96	271	82	60	36	65

KK	SW4	α [°]	1)	2)
M4	12	8	0.05-0.2	0-0.5

KK	SW4	$\alpha$ [°]	1)	2)
M5	13	8	0.05-0.2	0-0,5
M6x1	13	6	0.05-0.5	0-1,5
M8x1.25	17	8	0.05-0.5	0-1,5
M10x1.25	30	8	0.05-0.5	0-2
M12x1.25	30	7	0.05-0.5	0-2
M16x1.5	41	6	0.05-0.5	0-2
M20x1.5	41	6	0.05-0.5	0-2
M27x2	55	8	0.05-0.2	0-2
M36x2	75	8	0.05-0.2	0-2
M42x2	85	8	0.05-0.2	0-2

1) 轴向间隙

2) 径向间隙



柔性耦合连接件 PM7 , CM2 系列



螺纹尺寸	材料	物料号
M10x1,25	钢, 镀铬	1827001629
M16x1,5	钢, 镀铬	1827001631

规格

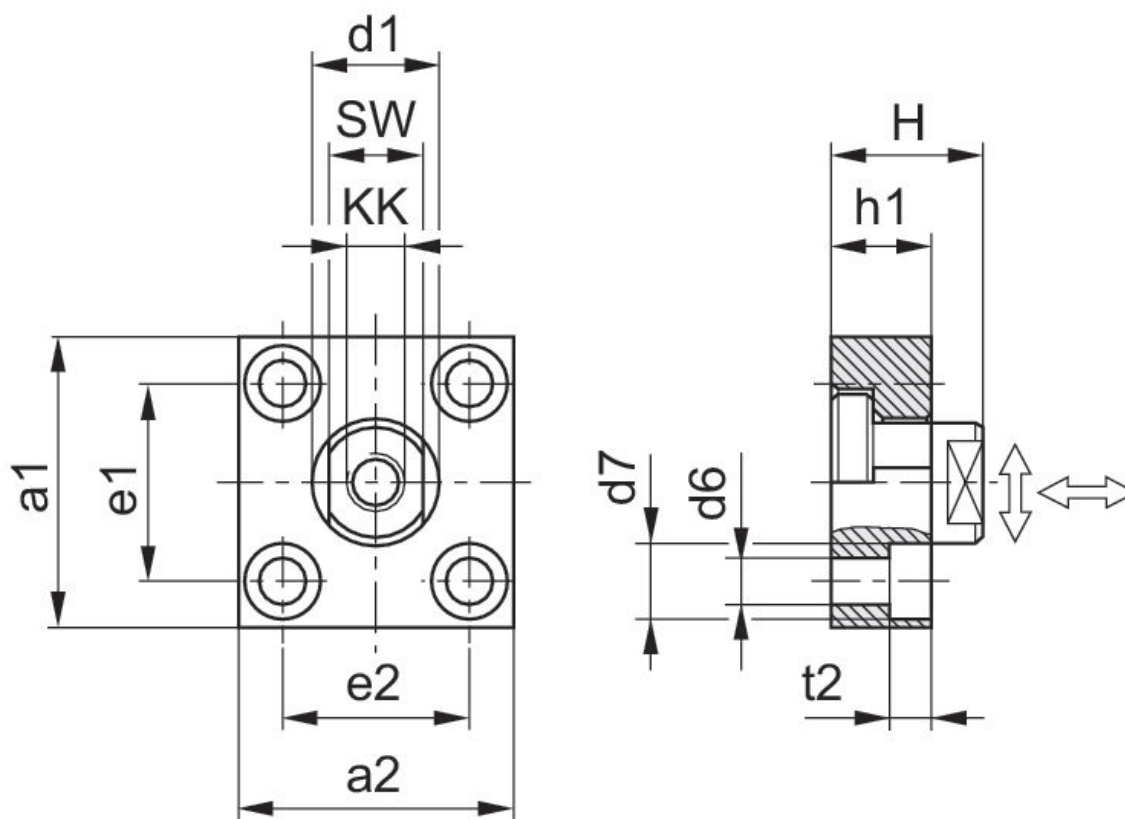

KK	物料号	a1	a2	d1 h11	d6 H13	d7 H13	e1 H13	e2	h1	t2
M10x1.25	1827001629	60	37	20	6.6	11	36 ±0,15	23 ±0,15	15	7
M12x1.25	1827001630	60	56	25	9	15	42 ±0,2	38 ±0,2	20	9
M16x1.5	1827001631	80	80	30	11	18	58 ±0,2	58 ±0,2	20	11
M20x1.5	1827001632	90	90	40	14	20	65 ±0,3	65 ±0,3	20	13
M27x2	1827001633	90	90	40	14	20	65 ±0,3	65 ±0,3	20	13

KK	物料号	a1	a2	d1 h11	d6 H13	d7 H13	e1 H13	e2	h1	t2
M36x2	1827001634	125	125	60	18	26	90 ±0,3	90 ±0,3	30	17

KK	H	SW	连接销的拧紧力矩最大 ± 5%	轴向间隙 最小/最大	径向间隙 最小/最大
M10x1.25	24	17	17 Nm	0,4 - 0,8 mm	1,9 - 2,3 mm
M12x1.25	30	19	29 Nm	0,4 - 0,8 mm	1,9 - 2,3 mm
M16x1.5	32	24	71 Nm	0,4 - 0,8 mm	1,9 - 2,3 mm
M20x1.5	35	36	138 Nm	0,4 - 0,8 mm	1,9 - 2,3 mm
M27x2	35	36	350 Nm	0,4 - 20,31 mm	1,9 - 2,3 mm
M36x2	55	50	1080 Nm	0,4 - 0,95 mm	2,8 - 3,4 mm

回转头AP6，CM2 系列



用于系列	万向轴承-Ø [mm]	材料	物料号
PRA, TRB, MNI, CCI, SSI, RPC, KPZ, 167, CVI, RDC	10	钢, 镀铬	1822124003
PRA, TRB, CCI, SSI, RPC, KPZ, 167, CVI, RDC, 102	16	钢, 镀铬	1822124005

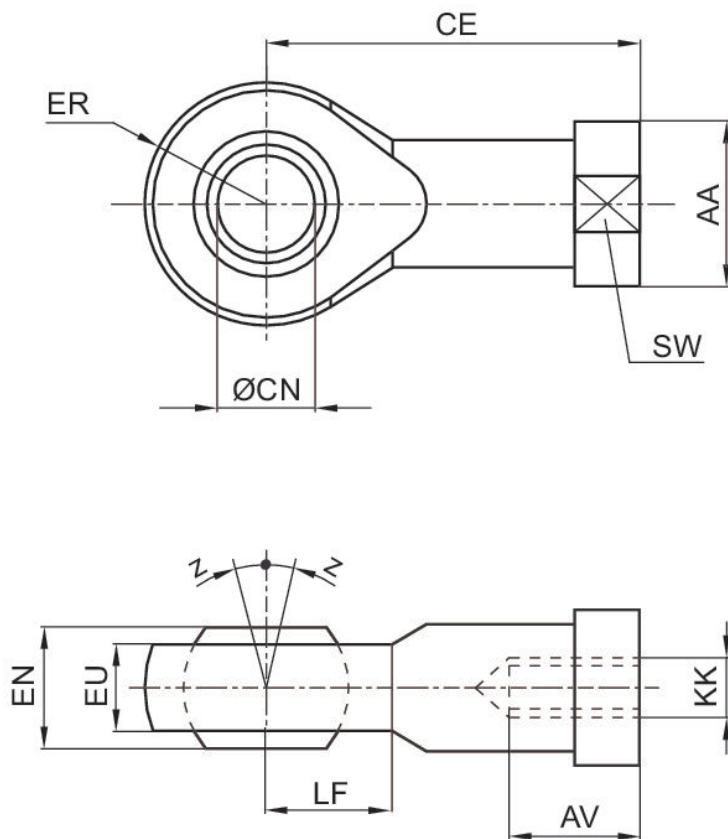

KK	物料号	AA	AV min.	CE	Ø CN H7	EN -0,1	ER	EU max.	LF	SW
M4	1822124000	12	8	27	5	8	9	7.5	9	9
M6	1822124001	13	9	30	6	9	10	7.5	10	11
M8	1822124002	16	12	36	8	12	12	9.5	12	14

KK	物料号	AA	AV min.	CE	Ø CN H7	EN -0,1	ER	EU max.	LF	SW
M10	8958206402	19	20	43	10	14	14	10.5	13	17
M12	8958208852	22	22	50	12	16	16	12	16	19
M10x1,25	1822124003	19	15	43	10	14	14	11.5	14	17
M12x1,25	1822124004	22	18	50	12	16	16	12.5	16	19
M16x1,5	1822124005	27	24	64	16	21	21	15.5	21	22
M20x1,5	1822124006	34	30	77	20	25	25	18.5	25	30
M24x2	8958208002	42	36	94	25	31	30	23	30	36
M27x2	1822124013	50	45	110	30	37	35	27	35	41
M36x2	1822124008	60	56	125	35	43	40	32	40	50
M42x2	1822124009	69	60	142	40	49	45.5	37	45	55
M48x2	8958208842	75	65	160	50	60	58	45	60	65

KK	Z [°] max.
M4	4
M6	4
M8	4
M10	6
M12	13
M10x1,25	4
M12x1,25	4
M16x1,5	4
M20x1,5	4
M24x2	15
M27x2	4
M36x2	4
M42x2	4
M48x2	6

活塞杆U形接头 AP2, 系列 CM2

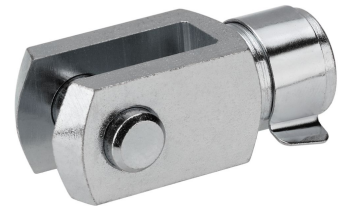

用于系列	材料	物料号
PRA, TRB, CCI, MNI, ICM, KPZ, 167, CVI, RPC, RDC	钢, 镀铬	1822122024
PRA, TRB, CCI, KPZ, 167, CVI, RPC, RDC, 102	钢, 镀铬	1822122005

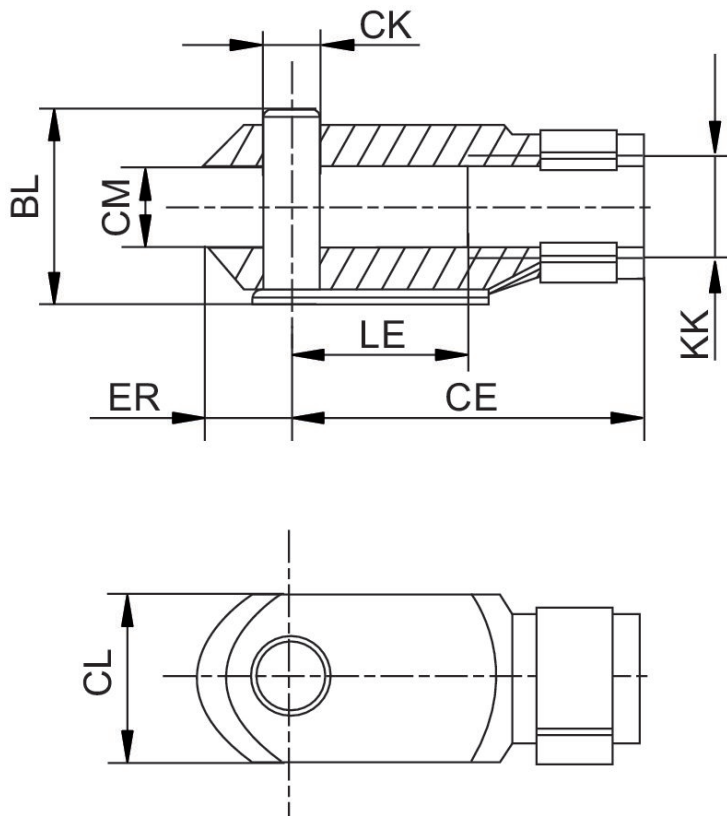

KK	物料号	BL	CE	ØCK e11	CL	CM	ØD1	ER	LE
M4	1822122028	11	16	4	8	4	8	5	8
M6	1822122009	16	24	6	12	6	10	7	12
M8	1822122010	21,5	32	8	16	8	14	10	16
M10x1,25	1822122024	26	40	10	20	10	18	12	20
M12x1,25	1822122025	31	48	12	24	12	20	14	24
M16x1,5	1822122005	39	64	16	32	16	26	19	32

KK	物料号	BL	CE	ØCK e11	CL	CM	ØD1	ER	LE
M20x1,5	1822122004	50	80	20	40	20	34	20	40
M10	8958000122	26	40	10	20	10	18	12	20
M12	8958000132	31	48	12	24	12	20	14	24
M48x2	8958019332	122	192	50	96	50	82	73	96
M5	1822122008	13.5	20	5	10	5	9	6	10

活塞杆U形接头 PM6, 系列 CM2



用于系列	万向轴承-Ø [mm]	材料	物料号
AP6	14	钢, 镀铬	1822122032
AP6	21	钢, 镀铬	1822122034

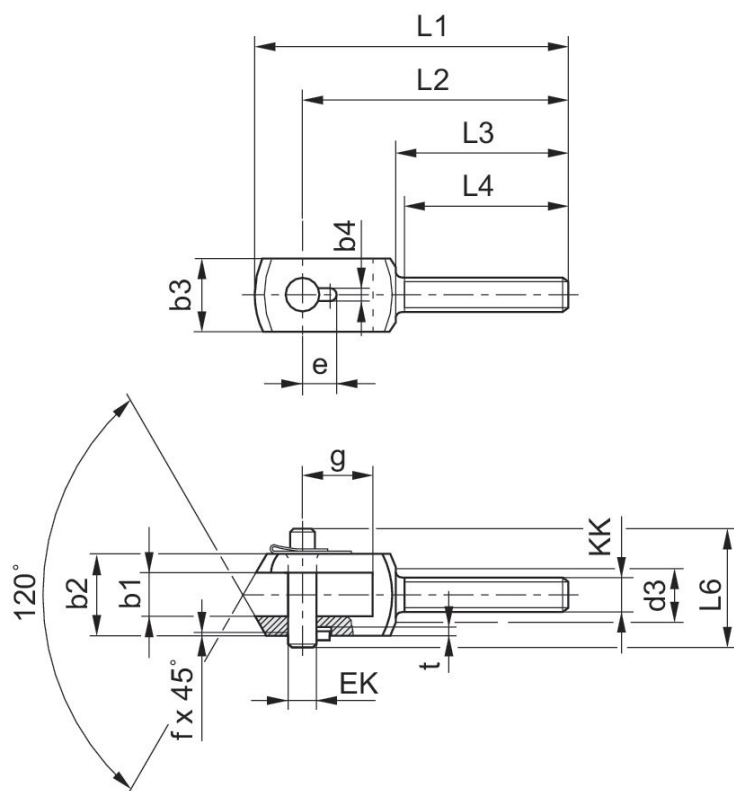

KK	物料号	b1 B12	b2 d12	b3	b4 +0,2	d3	e +0,3	EK	f	g
14	1822122032	14	28	20	3.3	17	11.5	10	0.7	20
16	1822122033	16	30	25	4.3	19	12	12	1	26
21	1822122034	21	40	35	4.3	24	14	16	1	31
25	1822122035	25	50	40	4.3	30	16	20	1	43
30	1822122036	37	67	60	6.3	38	24	30	1.5	54

KK	L1	L2	L3	L4 +1	L6	t +0,2
14	90	78	53	50	35	3
16	108	92	58	55	39	3
21	129	108	65	62	50	3
25	156	131	73	69	60	3
30	200	168	98	92	77	5



活塞杆的 螺母 MR9



螺纹尺寸	材料	物料号
M10x1,25	钢, 镀铬	1823A00020
M16x1,5	钢, 镀铬	1823300030

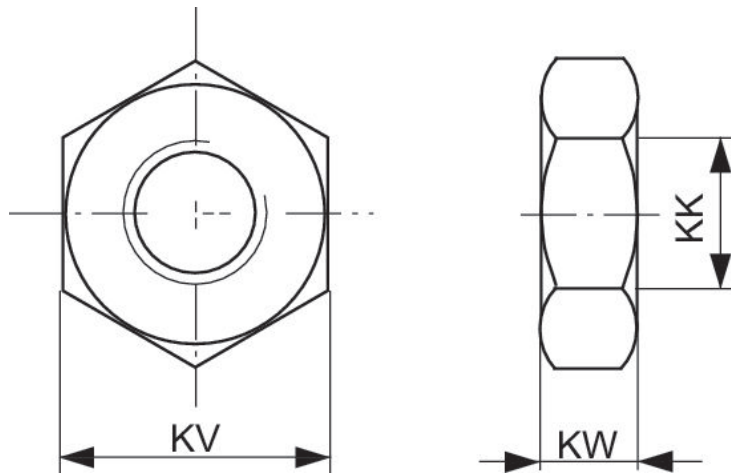

KK	物料号	KV	KW
M4	1823300033	10	3.2
M6	1823300034	13	4
M8	1823A00021	19	6
M10	8103190344	19	6
M10x1,25	1823300030	24	8
M20x1,5	1823300031	30	10
M27x2	1823A00029	41	13.5
M36x2	8103190414	50	16
M42x2	8103190424	60	21
M6	8103190644	10	3.2
M8	8103190164	13	4
M10x1,25	8103190464	17	5
M4	3330310000	7	2.2
M12x1,25	3590304000	19	6
M16x1,5	3590305000	24	8

KK	物料号	KV	KW
M20x1,5	3590308000	30	10
M20x1,5	8103040344	30	10
M24x2	8103190394	36	12
M48x2	8103190434	65	25
M10x1,25	2990600303	17	5
M12x1,25	2990600304	19	6
M16x1,5	2990600305	24	8
M20x1,5	2990600308	30	10
M27x2	2990600312	41	13.5
M36x2	2990600316	50	16
M42x2	2990600325	60	21

消音器，系列 SI1

外螺纹  
青铜烧结制成



压缩空气连接	声压级 [dB]	额定流量 [l/min]	供货数量 [件]	重量 [kg]	物料号
G 1/8	75	1623	10	0.01	1827000000
G 1/4		5950	10	0.013	R412004817
G 1/4	79	3390	10	0.02	1827000001
G 3/8	84	6554	5	0.05	1827000002

1827000000

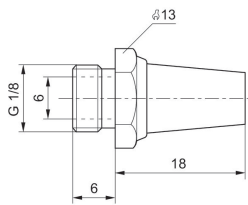

R412004817

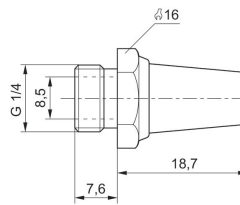

1827000001

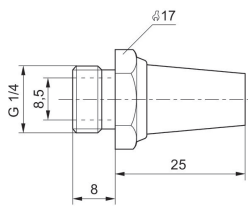

1827000002

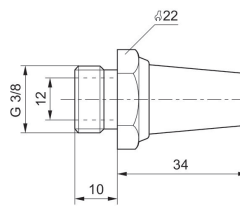

# Efficient pneumatic solutions, our program: cylinders and drives, valves and valve systems, air supply management



Visit us: [Emerson.com/Aventics](https://www.emerson.com/Aventics)

Your local contact: [Emerson.com/contactus](https://www.emerson.com/contactus)



[Emerson.com](https://www.emerson.com)



[Facebook.com/EmersonAutomationSolutions](https://www.facebook.com/EmersonAutomationSolutions)



[LinkedIn.com/company/Emerson-Automation-Solutions](https://www.linkedin.com/company/Emerson-Automation-Solutions)



[Twitter.com/EMR\\_Automation](https://twitter.com/EMR_Automation)

An example configuration is depicted on the title page. The delivered product may thus vary from that in the illustration. Subject to change. This Document, as well as the data, specifications and other information set forth in it, are the exclusive property of AVENTICS GmbH. It may not be reproduced or given to third parties without its consent. Only use the AVENTICS products shown in industrial applications. Read the product documentation completely and carefully before using the product. Observe the applicable regulations and laws of the respective country. When integrating the product into applications, note the system manufacturer's specifications for safe use of the product. The data specified only serve to describe the product. No statements concerning a certain condition or suitability for a certain application can be derived from our information. The information given does not release the user from the obligation of own judgment and verification. It must be remembered that the products are subject to a natural process of wear and aging.

The Emerson logo is a trademark and service mark of Emerson Electric Co. Brand logotype are registered trademarks of one of the Emerson family of companies. All other marks are the property of their respective owners. © 2019 Emerson Electric Co. All rights reserved.



**CONSIDER IT SOLVED™**