

系列 102



AVENTICS™

AVENTICS 102 膜片式气缸

EMERSON™

系列 102

安沃驰 102 系列是一种可以使空压系统应用产生较大出力的高效实惠的解决方案。

- Ø 60 ... 250 mm
- 双作用式和单作用式，无压缩回



总览图

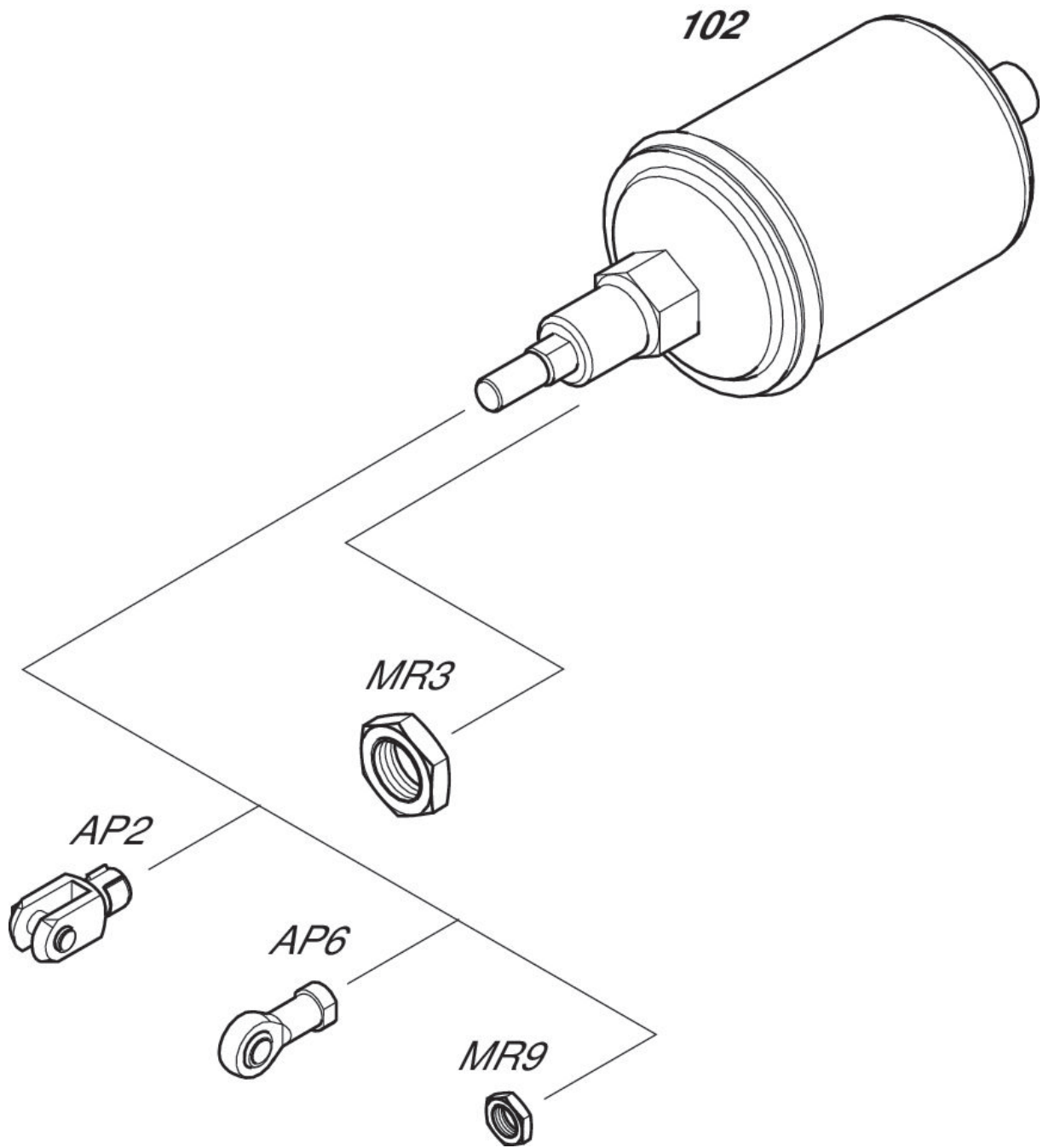

膜片式气缸, 系列 102

膜片式气缸
 外螺纹
 标准螺纹
 内螺纹
 单作用式, 不受压缩回

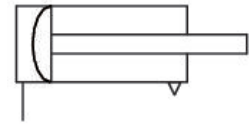

活塞-Ø [mm]	行程 [mm]	实用原则	弹簧力, 最小值 [N]	弹簧力, 最大值 [N]	伸出运动的 活塞力 [N]	活塞杆螺纹	螺纹接口	重量 [kg]	物料号
80	40	单作用式, 不受压缩回	100	300	3000	M12	G 1/4	2.8	1025100000
113	50	单作用式, 不受压缩回	100	650	6000	M16	G 1/4	5.6	1025200000
160	50	单作用式, 不受压缩回	240	1000	12000	M20	G 1/2	12.2	1025300000

规格

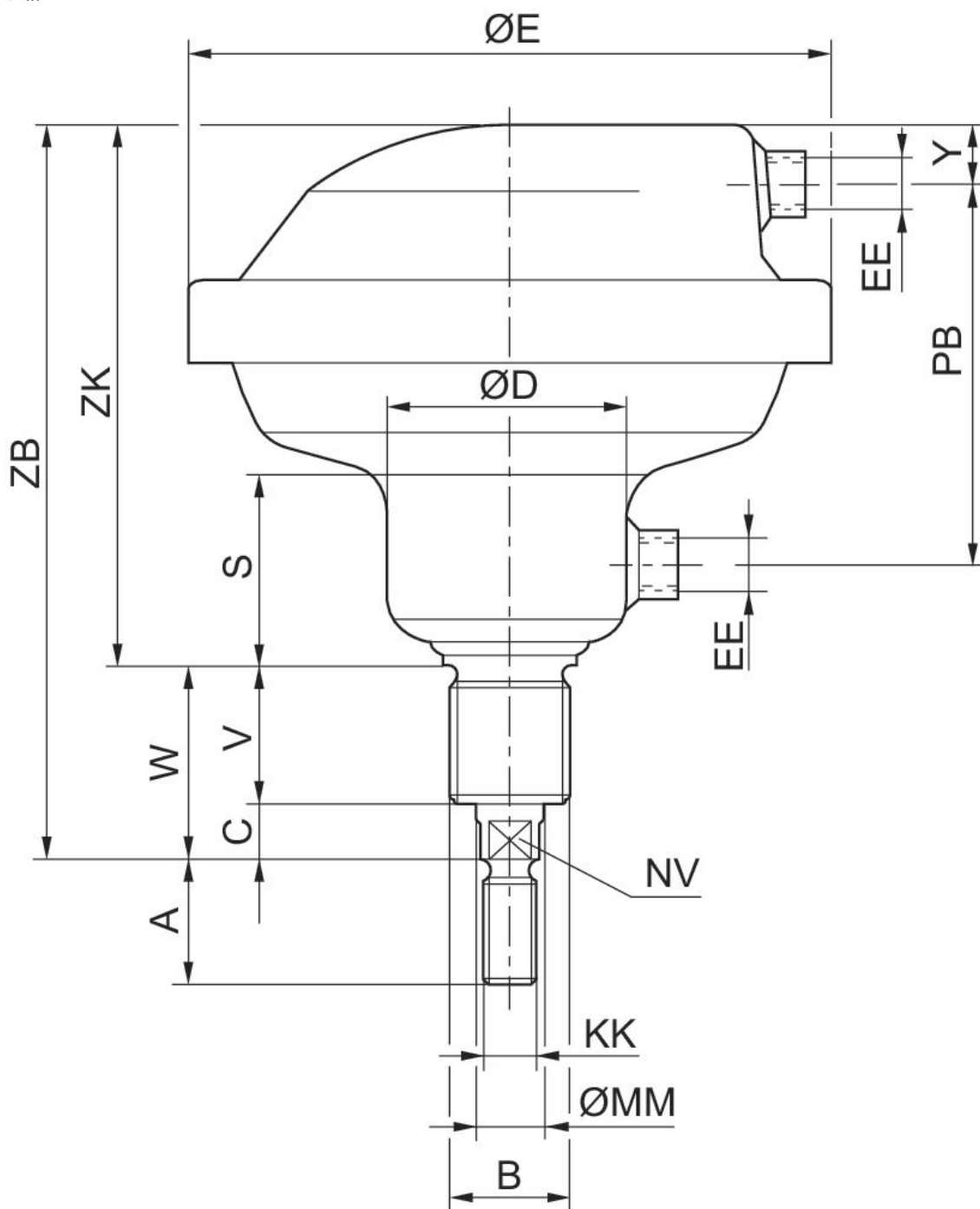

活塞- \varnothing	物料号	A	B	C	D	E	S	V	W	Y
80	1025100000	24	M24x2	14	55	150	48	38	52	15
113	1025200000	32	M36x3	20	71	195	55	38	58	15
160	1025300000	40	M36x3	20	88	261	58	45	65	26

活塞- Ø	EE	KK	MM	NV	PB	ZB	ZK
80	G 1/4	M12	16	13	90	183	131
113	G 1/4	M16	20	17	107	212	154
160	G 1/2	M20	25	22	117	243	178

膜片式气缸, 系列 102

膜片式气缸
 外螺纹
 细牙螺纹
 内螺纹
 单作用式, 不受压缩回

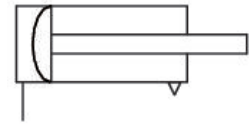

活塞-Ø [mm]	行程 [mm]	实用原则	弹簧力, 最小值 [N]	弹簧力, 最大值 [N]	伸出运动的 活塞力 [N]	活塞杆螺纹	螺纹接口	重量 [kg]	物料号
80	40	单作用式, 不受压缩回	100	300	3000	M12x1,25	G 1/4	2.8	1020100000
113	50	单作用式, 不受压缩回	100	650	6000	M16x1,5	G 1/4	5.6	1020200000
160	50	单作用式, 不受压缩回	240	1000	12000	M20x1,5	G 1/2	12.2	1020300000

规格

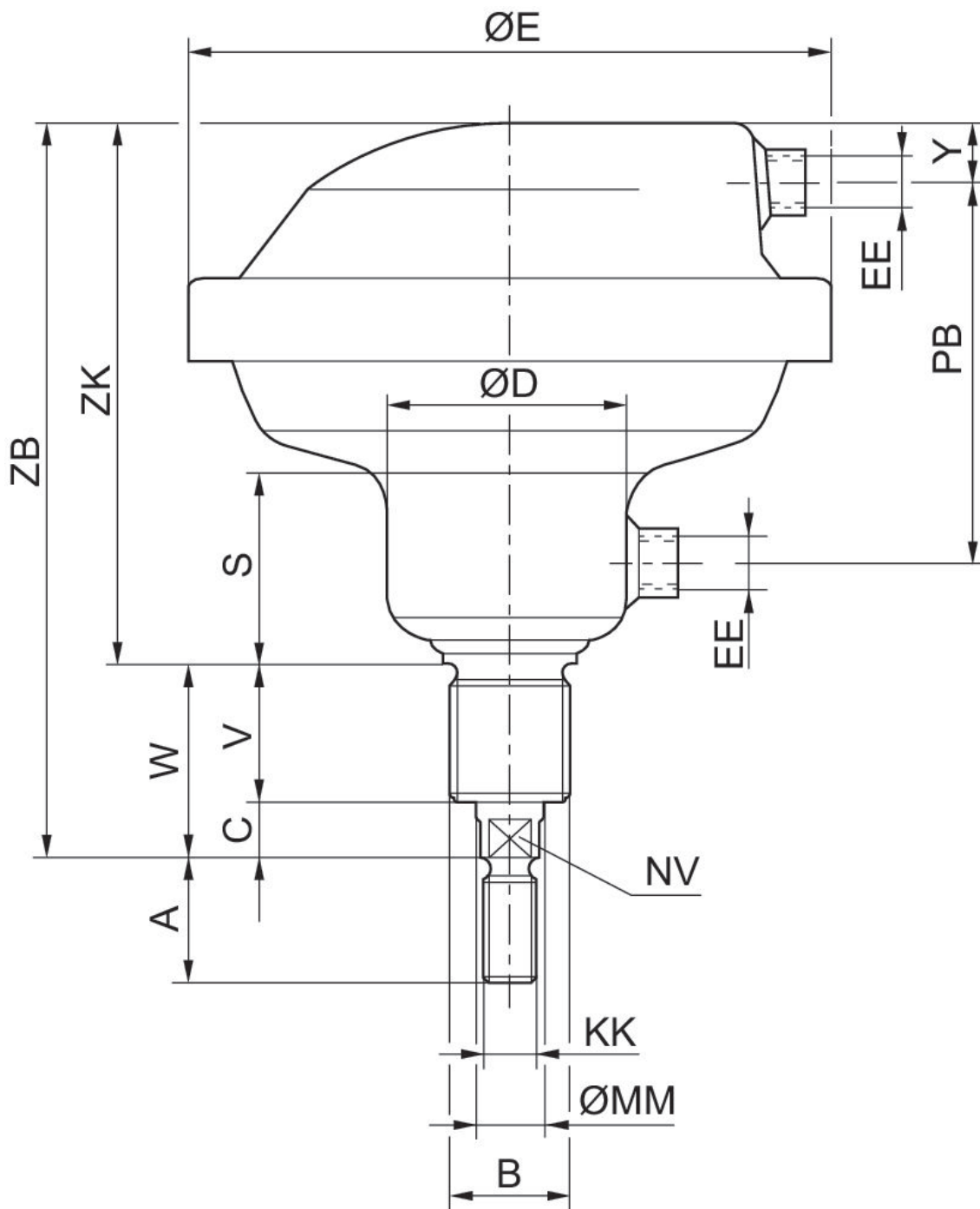

物料号	活塞-Ø	A	B	C	D	E	S	V	W	Y
1020100000	80	24	M24x2	14	55	150	48	38	52	15
1020200000	113	32	M36x3	20	71	195	55	38	58	15
1020300000	160	40	M36x3	20	88	261	58	45	65	26

物料号	活塞-Ø	EE	KK	MM	NV	PB	ZB	ZK
1020100000	80	G 1/4	M12x1.25	16	13	90	183	131
1020200000	113	G 1/4	M16x1.5	20	17	107	212	154
1020300000	160	G1/2	M20x1.5	25	22	117	243	178

膜片式气缸, 系列 102

膜片式气缸
外螺纹
标准螺纹
内螺纹
双作用式

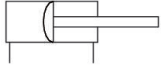
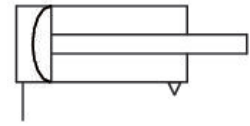

活塞-Ø [mm]	行程 [mm]	实用原则	弹簧力, 最小值 [N]	缩回运动的 活塞力 [N]	伸出运动的 活塞力 [N]	活塞杆螺纹	螺纹接口	重量 [kg]	物料号
80	40	双作用式		2880	3000	M12	G 1/4	2.6	1026100000
113	50	双作用式	100	5800	6000	M16	G 1/4	5.4	1026200000
160	50	双作用式		11600	12000	M20	G 1/2	11.4	1026300000

规格

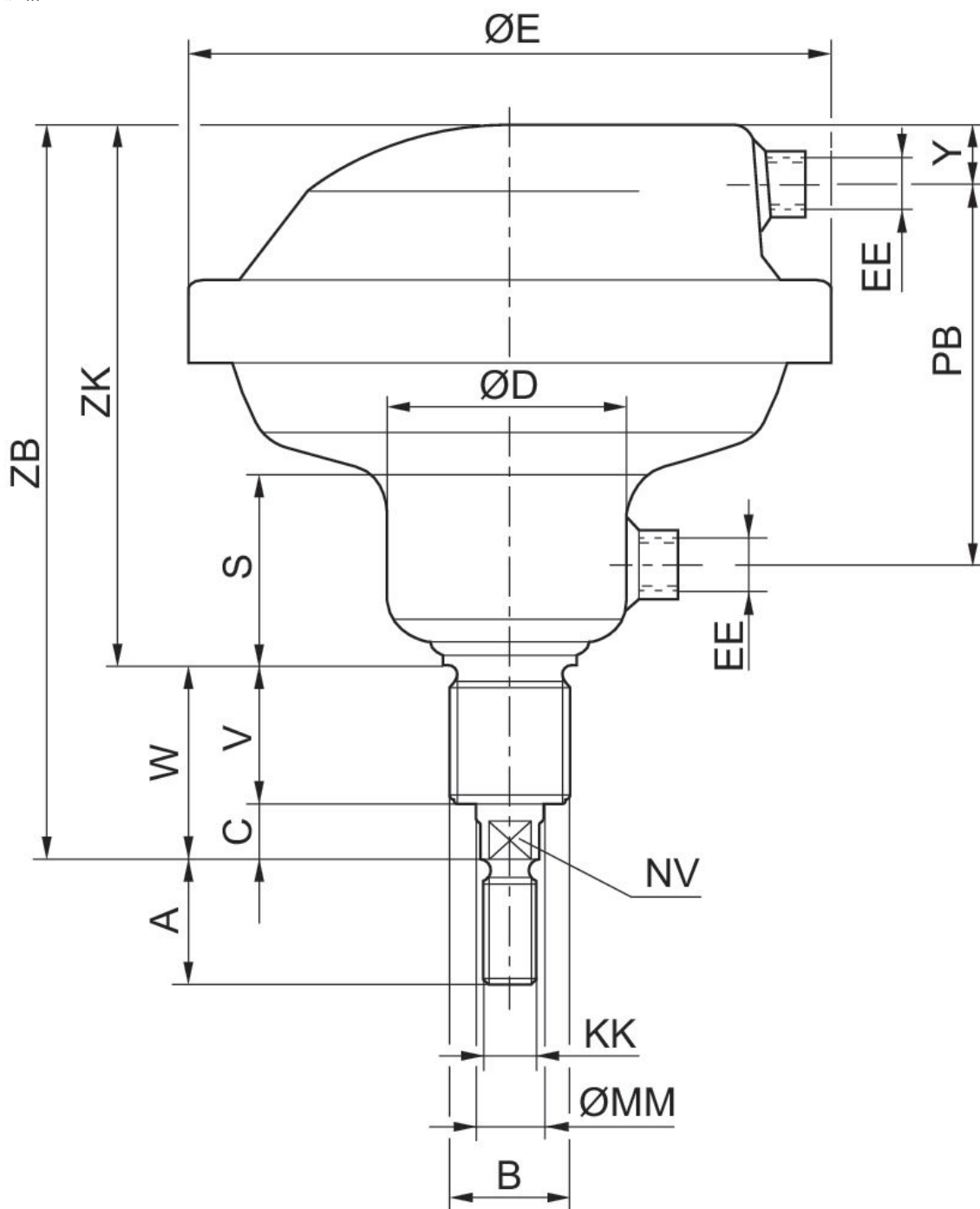

物料号	活塞- \varnothing	A	B	C	D	E	S	V	W	Y
1026100000	80	24	M24x2	14	55	150	48	38	52	15
1026200000	113	32	M36x3	20	71	195	55	38	58	15
1026300000	160	40	M36x3	20	88	261	58	45	65	26

物料号	活塞-Ø	EE	KK	MM	NV	PB	ZB	ZK
1026100000	80	G 1/4	M12	16	13	90	183	131
1026200000	113	G 1/4	M16	20	17	107	212	154
1026300000	160	G 1/2	M20	25	22	117	243	178

膜片式气缸, 系列 102

膜片式气缸
外螺纹
细牙螺纹
内螺纹
双作用式

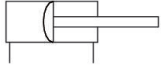
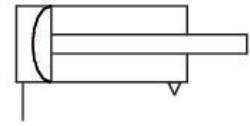

活塞-Ø [mm]	行程 [mm]	实用原则	弹簧力, 最小值 [N]	缩回运动的 活塞力 [N]	伸出运动的 活塞力 [N]	活塞杆螺纹	螺纹接口	重量 [kg]	物料号
80	40	双作用式		2880	3000	M12x1,25	G 1/4	2.6	1021100000
113	50	双作用式	100	5800	6000	M16x1,5	G 1/4	5.4	1021200000
160	50	双作用式		11600	12000	M20x1,5	G 1/2	11.4	1021300000

规格

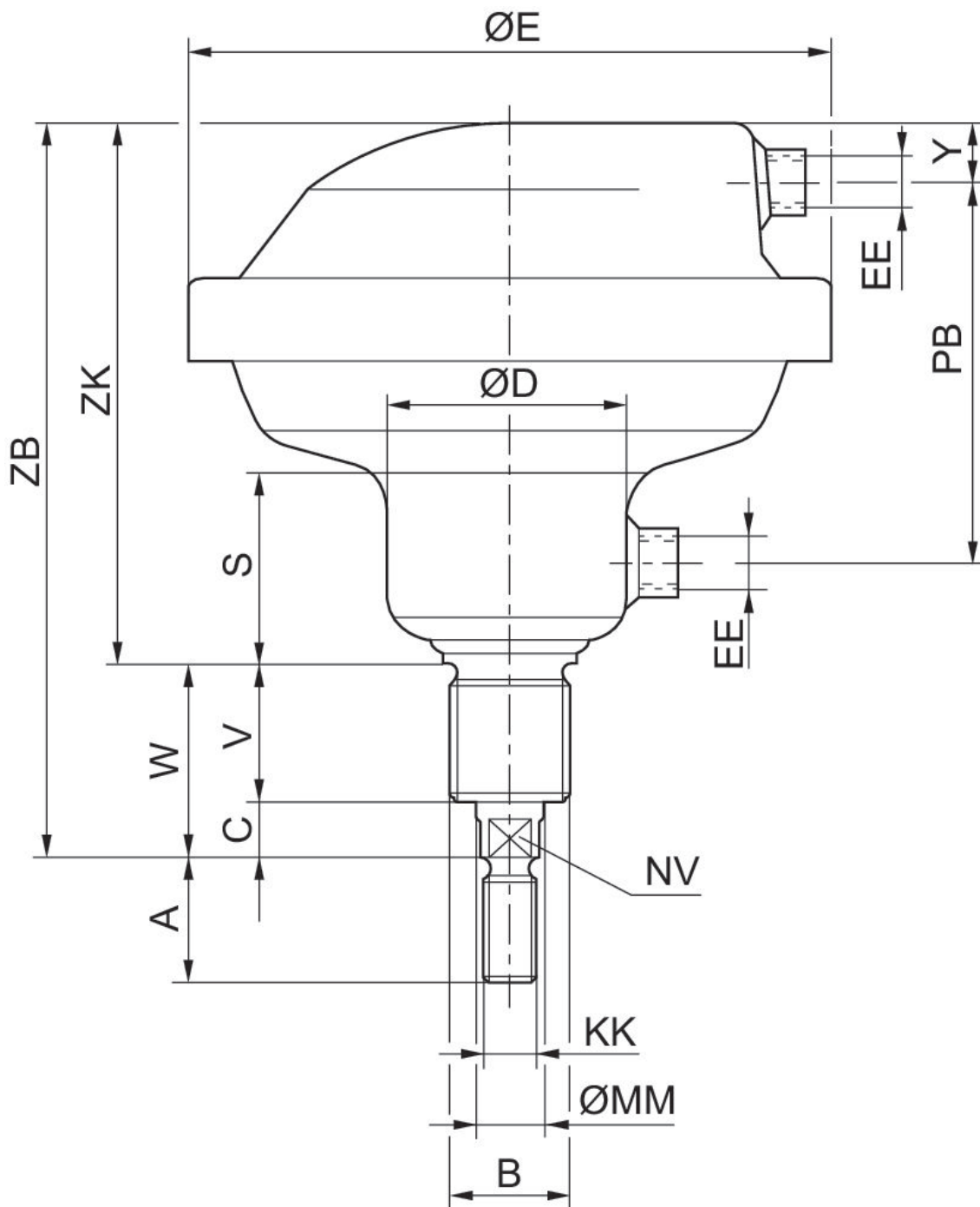

物料号	活塞-Ø	A	B	C	D	E	S	V	W	Y
1021100000	80	24	M24x2	14	55	150	48	38	52	15
1021200000	113	32	M36x3	20	71	195	55	38	58	15
1021300000	160	40	M36x3	20	88	261	58	45	65	26

物料号	活塞-Ø	EE	KK	MM	NV	PB	ZB	ZK
1021100000	80	G 1/4	M12x1.25	16	13	90	183	131
1021200000	113	G 1/4	M16x1.5	20	17	107	212	154
1021300000	160	G 1/2	M20x1.5	25	22	117	243	178

活塞杆气缸, 系列 102

膜片式气缸
外螺纹
标准螺纹
内螺纹
单作用式, 不受压缩回



活塞-Ø [mm]	行程 [mm]	实用原则	弹簧力, 最小值 [N]	弹簧力, 最大值 [N]	伸出运动的 活塞力 [N]	活塞杆螺纹	螺纹接口	重量 [kg]	物料号
60	80	单作用式, 不受压缩回	130	320	1600	M12	G 1/4	1	1027100000
85	80	单作用式, 不受压缩回	130	320	3000	M12	G 1/4	1.5	1027200000
250	100	单作用式, 不受压缩回	900	2750	25000	M24	G 1/2	22.2	1027300000

规格

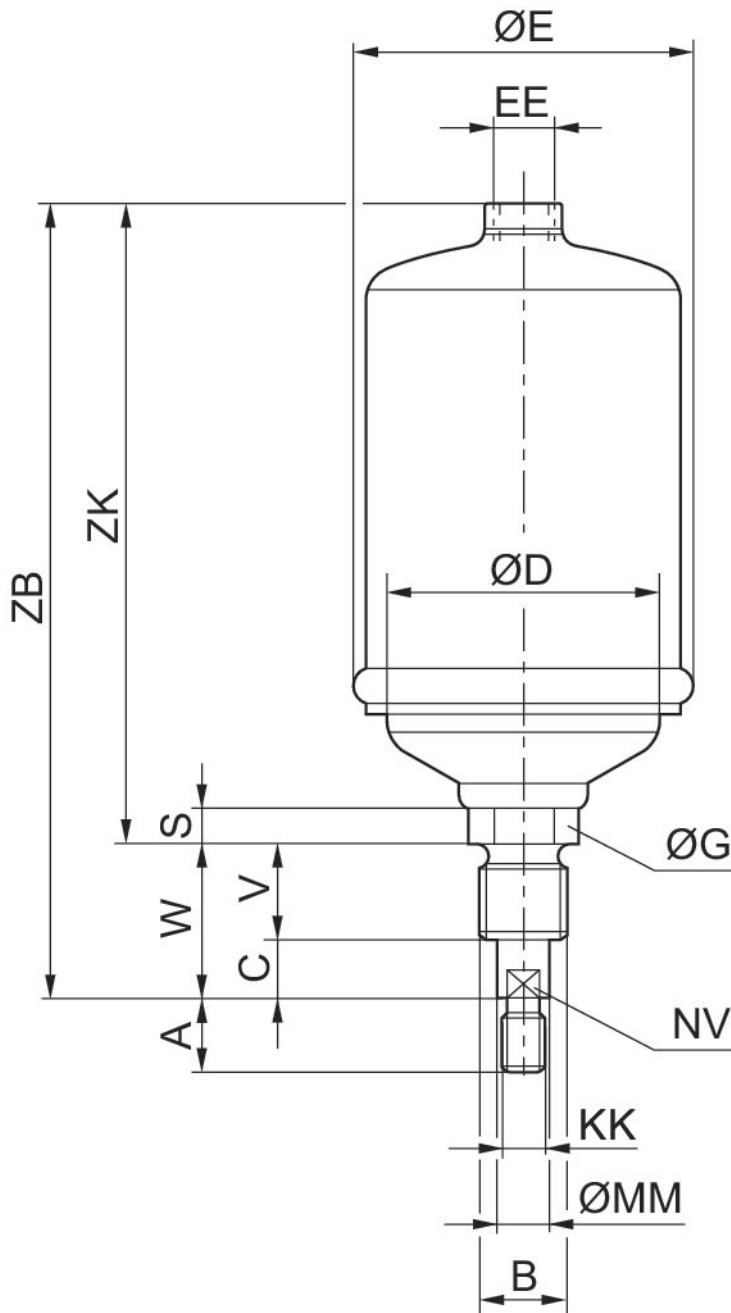

物料号	活塞-Ø	A	B	C	D	E	G	S	V	W
1027100000	60	24	M 24	11	54	66	30	18	30	41
1027200000	85	24	M24	11	77	93	30	18	30	41
1027300000	250	48	M48x3	20	56	268	50	33	40	60

物料号	活塞-Ø	EE	KK	MM	NV	ZB	ZK
1027100000	60	G 1/4	M12	14	12	222	181
1027200000	85	G 1/4	M12	14	12	222	181

物料号	活塞-Ø	EE	KK	MM	NV	ZB	ZK
1027300000	250	G 1/2	M24	28	25	385	325

活塞杆气缸, 系列 102

膜片式气缸
外螺纹
细牙螺纹
内螺纹
单作用式, 不受压缩回



活塞-Ø [mm]	行程 [mm]	实用原则	弹簧力, 最小值 [N]	弹簧力, 最大值 [N]	伸出运动的 活塞力 [N]	活塞杆螺纹	螺纹接口	重量 [kg]	物料号
60	80	单作用式, 不受压缩回	130	320	1600	M12x1,25	G 1/4	1	1022100000
85	80	单作用式, 不受压缩回	130	320	3000	M12x1,25	G 1/4	1.5	1022200000
250	100	单作用式, 不受压缩回	900	2750	25000	M24x2	G 1/2	22.2	1022300000

规格

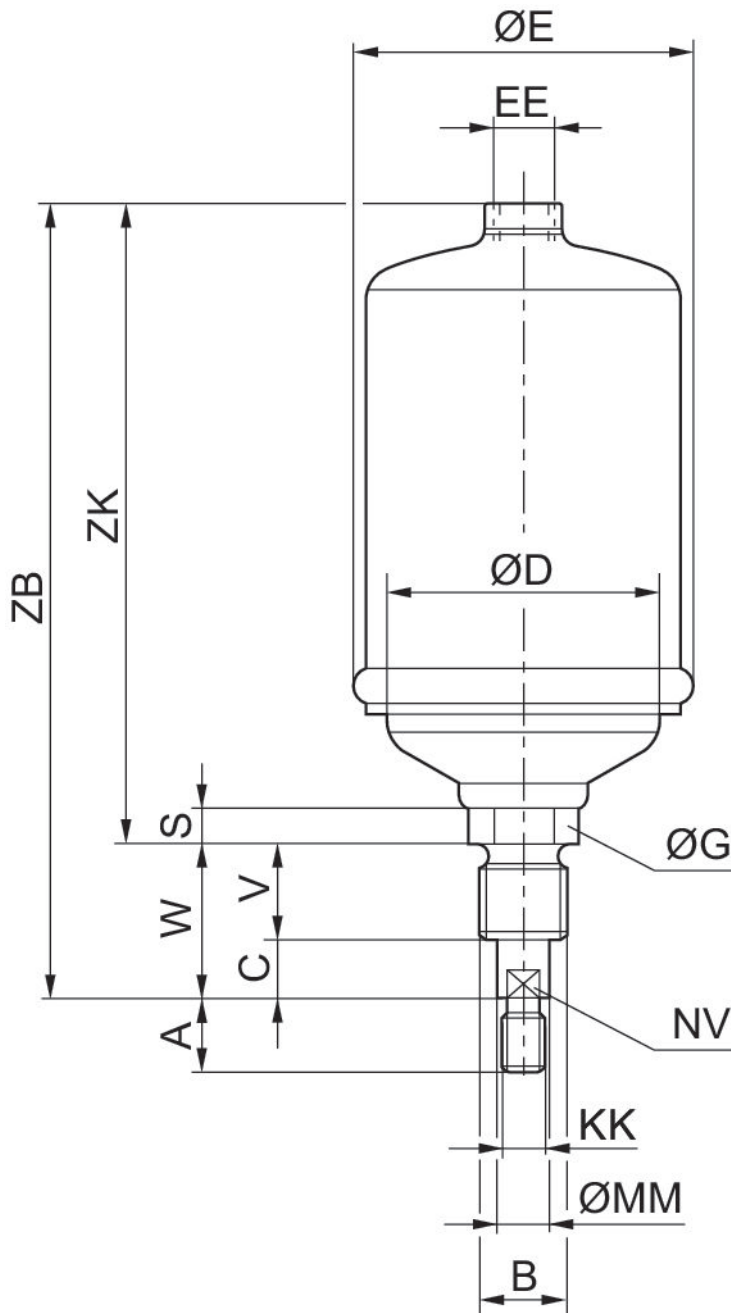

物料号	活塞-Ø	A	B	C	D	E	G	S	V	W
1022100000	60	24	M 24	11	54	66	30	18	30	41
1022200000	85	24	M24	11	77	93	30	18	30	41
1022300000	250	48	M48x3	20	56	268	50	33	40	60

物料号	活塞-Ø	EE	KK	MM	NV	ZB	ZK
1022100000	60	G 1/4	M12x1.25	14	12	222	181
1022200000	85	G 1/4	M12x1.25	14	12	222	181

物料号	活塞-Ø	EE	KK	MM	NV	ZB	ZK
1022300000	250	G 1/2	M24x2	28	25	385	325

活塞杆气缸, 系列 102

膜片式气缸
外螺纹
标准螺纹
内螺纹
双作用式

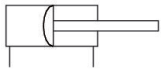

活塞- Ø [mm]	行程 [mm]	实用原则	缩回运动的 活塞力 [N]	伸出运动的 活塞力 [N]	活塞杆螺纹	螺纹接口	重量 [kg]	物料号
250	80	双作用式	24300	25000	M24	G 1/2	21.6	1028300000

规格

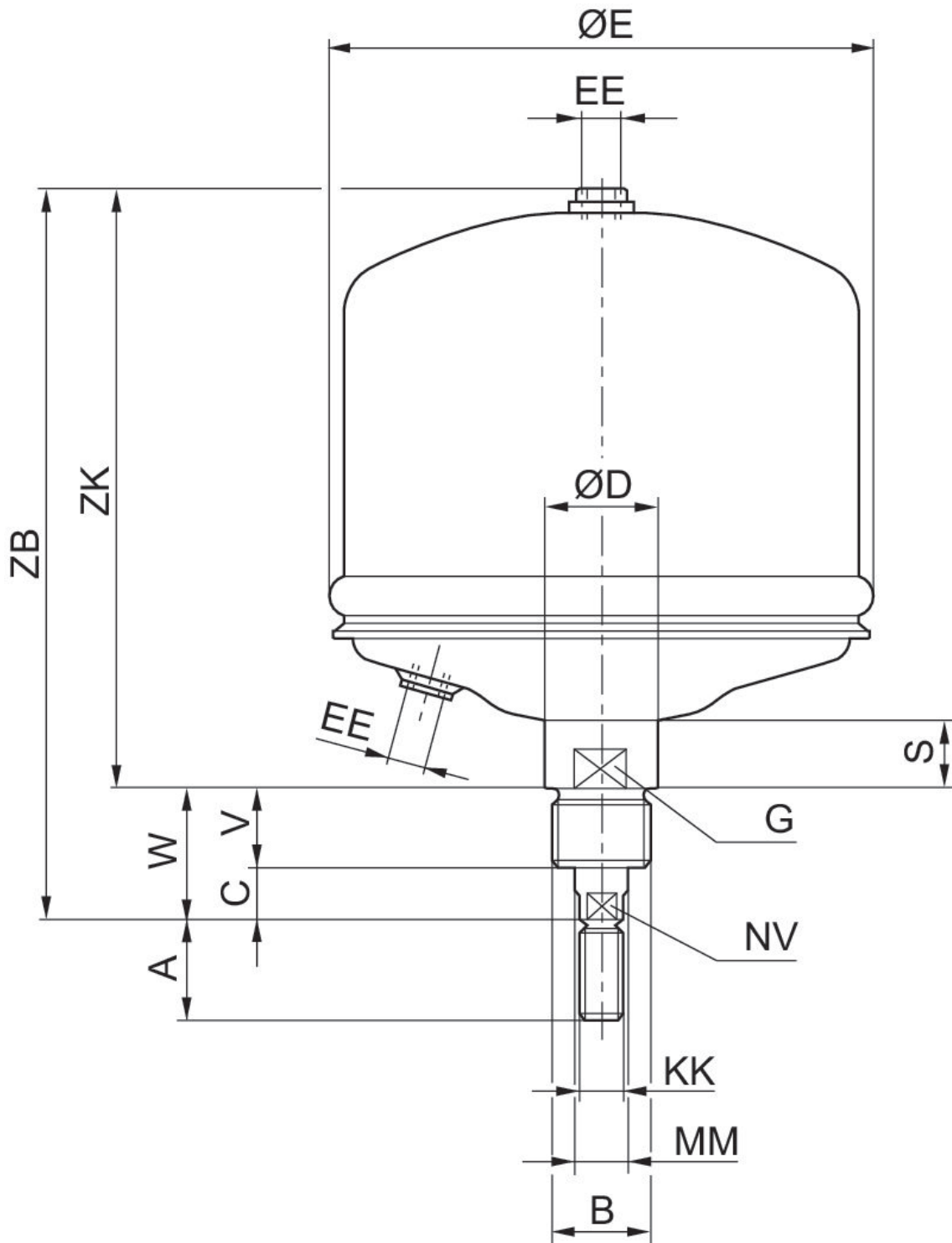

物料号	活塞- \varnothing	A	B	C	D	E	G	S	V	W
1028300000	250	48	M48x3	20	56	268	50	33	40	60

物料号	活塞-Ø	EE	KK	MM	NV	ZB	ZK
1028300000	250	G 1/2	M24	28	25	385	325

活塞杆气缸, 系列 102

膜片式气缸
外螺纹
细牙螺纹
内螺纹
双作用式

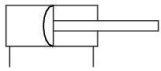

活塞- Ø [mm]	行程 [mm]	实用原则	缩回运动的 活塞力 [N]	伸出运动的 活塞力 [N]	活塞杆螺纹	螺纹接口	重量 [kg]	物料号
250	80	双作用式	24300	25000	M24x2	G 1/2	21.6	1023300000

规格

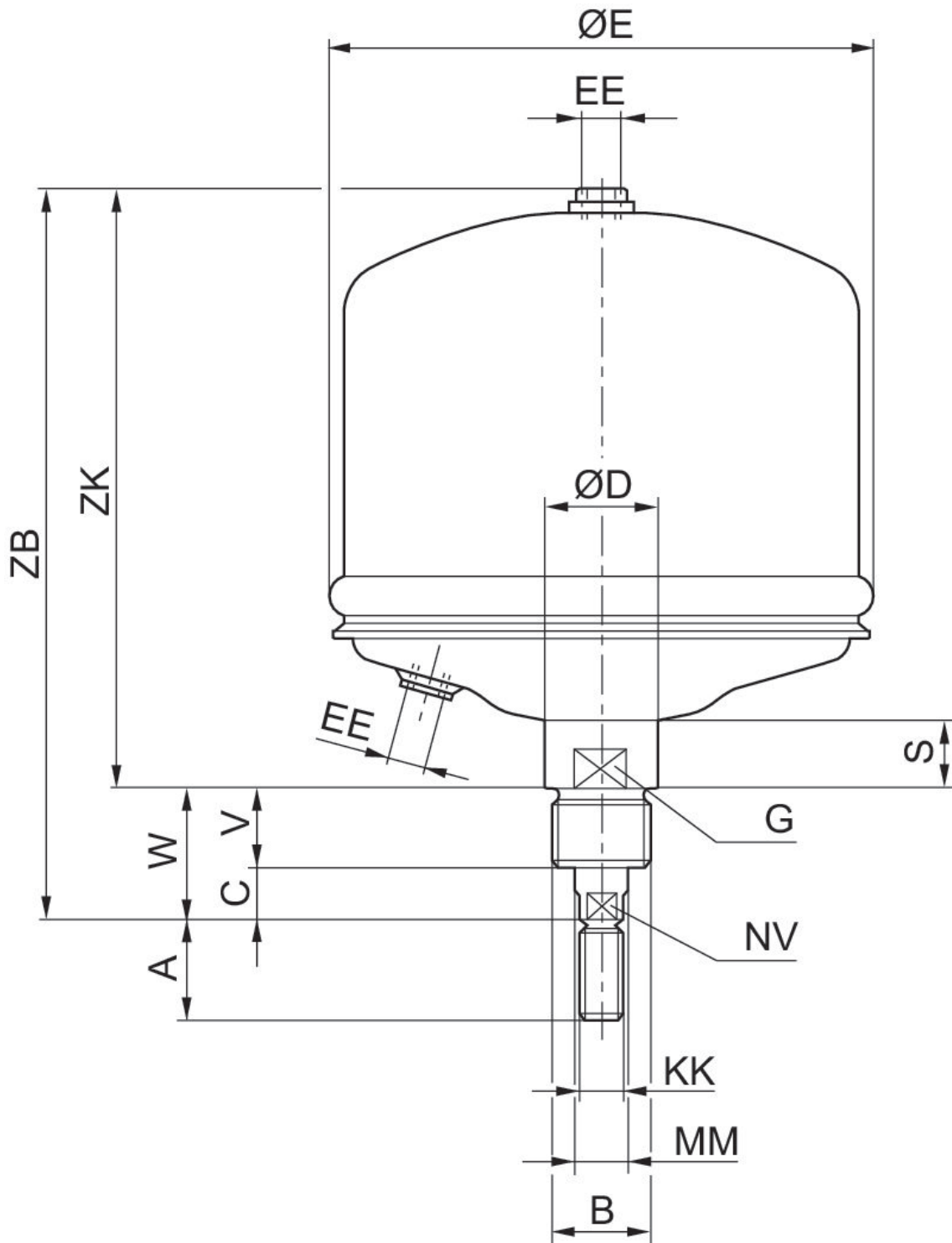

物料号	活塞- \varnothing	A	B	C	D	E	G	S	V	W
1023300000	250	48	M48x3	20	56	268	50	33	40	60

物料号	活塞-Ø	EE	KK	MM	NV	ZB	ZK
1023300000	250	G 1/2	M24x2	28	25	385	325

螺母 MR3 , CM1 系列



对应的活塞直径Ø [mm]	螺纹尺寸	材料	物料号
80	M24x2	钢, 镀铬	3008010180
60, 85	M24	钢, 镀铬	3056010180
113, 160	M36x3	钢, 镀铬	3012010180
250	M48x3	钢, 镀铬	3075010180

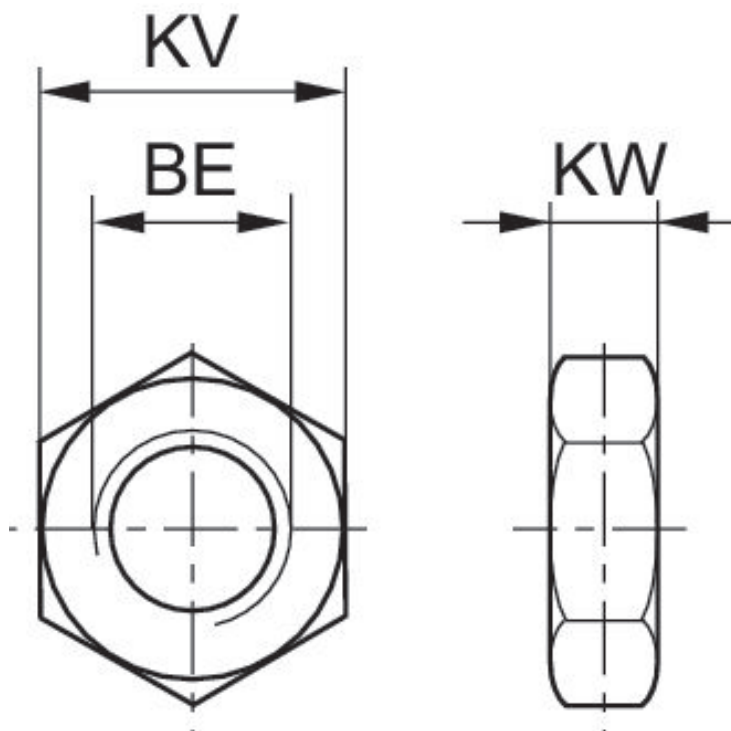

活塞- Ø	物料号	用于系列	BE	KV	KW
8, 10	1823300024	MNI	M12x1,25	17	5.5
12, 16	2915A51204	MNI	M16x1,5	22	6
20, 25	2915051207	CSL-RD, MNI	M22x1,5	30	7
8, 10	0413215803	ICM	M12x1,25	17	6.75
16	0413214505	ICM	M16x1,5	24	7

活塞- Ø	物料号	用于系列	BE	KV	KW
16	2918540030	CSL-RD	M16 x1,5	27	8
20, 25	0413214602	ICM	M22 x1,5	30	8
20, 25	R913030290	CSL-RD	M22 x1,5	32	11
32	0413214718	ICM	M30x1,5	41	11
80	3008010180	102	M24x2	36	8
60, 85	3056010180	102	M24	36	8
32	R412027809	102	M30x1,5	36	10
40	R412027810	RPC	M36x1,5	46	10
113, 160	3012010180	102	M36x3	52	10
40	R412027811	RPC	M38x1,5	46	10
50, 63	R412027812	RPC	M45x1,5	60	12
250	3075010180	102	M48x3	65	12

活塞杆U形接头 AP2, 系列 CM2

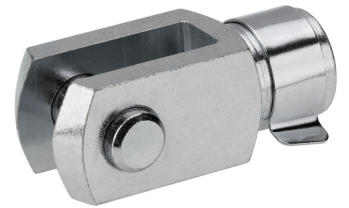

适合的活塞杆螺纹	用于系列	材料	物料号
M12	RPC, 102	钢, 镀铬	8958000132
M12x1,25	PRA, TRB, CCI, KPZ, 167, CVI, RPC, 102	钢, 镀铬	1822122025
M16x1,5	PRA, TRB, CCI, KPZ, 167, CVI, RPC, RDC, 102	钢, 镀铬	1822122005
M20x1,5	PRA, TRB, KPZ, 167, CVI, 102	钢, 镀铬	1822122004

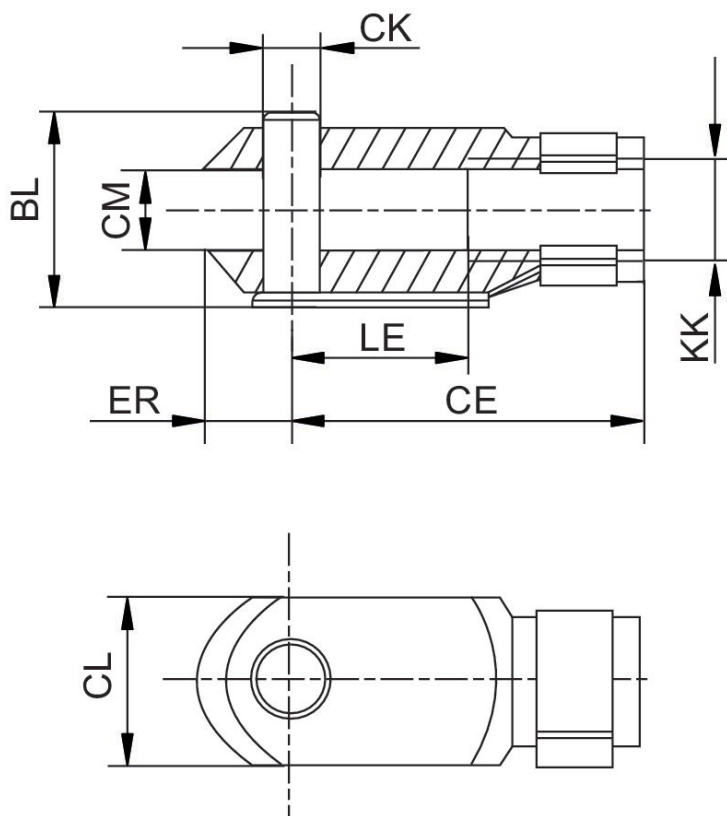

KK	物料号	BL	CE	ØCK e11	CL	CM	ØD1	ER	LE
M4	1822122028	11	16	4	8	4	8	5	8
M6	1822122009	16	24	6	12	6	10	7	12

KK	物料号	BL	CE	ØCK e11	CL	CM	ØD1	ER	LE
M8	1822122010	21,5	32	8	16	8	14	10	16
M10x1,25	1822122024	26	40	10	20	10	18	12	20
M12x1,25	1822122025	31	48	12	24	12	20	14	24
M16x1,5	1822122005	39	64	16	32	16	26	19	32
M20x1,5	1822122004	50	80	20	40	20	34	20	40
M10	8958000122	26	40	10	20	10	18	12	20
M12	8958000132	31	48	12	24	12	20	14	24
M48x2	8958019332	122	192	50	96	50	82	73	96
M5	1822122008	13.5	20	5	10	5	9	6	10

活塞杆U形接头 PM6, 系列 CM2



用于系列	万向轴承-Ø [mm]	材料	物料号
AP6	16	钢, 镀铬	1822122033
AP6	25	钢, 镀铬	1822122035

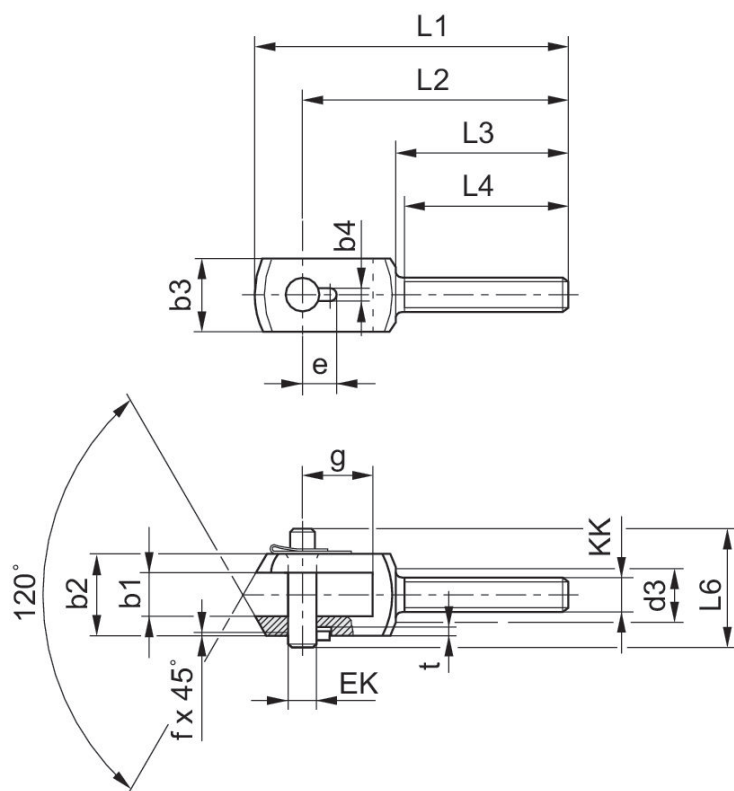

KK	物料号	b1 B12	b2 d12	b3	b4 +0,2	d3	e +0,3	EK	f	g
14	1822122032	14	28	20	3.3	17	11.5	10	0.7	20
16	1822122033	16	30	25	4.3	19	12	12	1	26
21	1822122034	21	40	35	4.3	24	14	16	1	31
25	1822122035	25	50	40	4.3	30	16	20	1	43
30	1822122036	37	67	60	6.3	38	24	30	1.5	54

KK	L1	L2	L3	L4 +1	L6	t +0,2
14	90	78	53	50	35	3
16	108	92	58	55	39	3
21	129	108	65	62	50	3
25	156	131	73	69	60	3
30	200	168	98	92	77	5

回转头AP6，CM2 系列



适合的活塞杆螺纹	用于系列	万向轴承-Ø [mm]	材料	物料号
M12x1,25	PRA, TRB, CCI, SSI, RPC, KPZ, 167, CVI, 102	12	钢, 镀铬	1822124004
M16x1,5	PRA, TRB, CCI, SSI, RPC, KPZ, 167, CVI, RDC, 102	16	钢, 镀铬	1822124005
M20x1,5	PRA, TRB, KPZ, 167, CVI, 102	20	钢, 镀铬	1822124006
M24x2		25	钢, 镀铬	8958208002

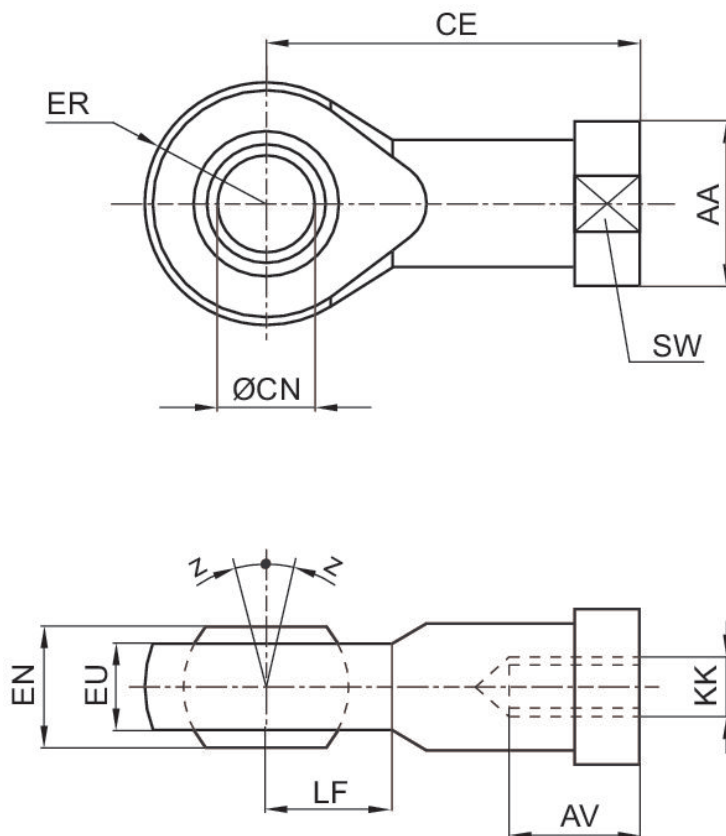

KK	物料号	AA	AV min.	CE	Ø CN H7	EN -0,1	ER	EU max.	LF	SW
M4	1822124000	12	8	27	5	8	9	7.5	9	9
M6	1822124001	13	9	30	6	9	10	7.5	10	11
M8	1822124002	16	12	36	8	12	12	9.5	12	14
M10	8958206402	19	20	43	10	14	14	10.5	13	17
M12	8958208852	22	22	50	12	16	16	12	16	19
M10x1,25	1822124003	19	15	43	10	14	14	11.5	14	17
M12x1,25	1822124004	22	18	50	12	16	16	12.5	16	19
M16x1,5	1822124005	27	24	64	16	21	21	15.5	21	22
M20x1,5	1822124006	34	30	77	20	25	25	18.5	25	30
M24x2	8958208002	42	36	94	25	31	30	23	30	36
M27x2	1822124013	50	45	110	30	37	35	27	35	41
M36x2	1822124008	60	56	125	35	43	40	32	40	50
M42x2	1822124009	69	60	142	40	49	45.5	37	45	55
M48x2	8958208842	75	65	160	50	60	58	45	60	65

KK	Z [°] max.
M4	4
M6	4
M8	4
M10	6
M12	13
M10x1,25	4
M12x1,25	4
M16x1,5	4
M20x1,5	4
M24x2	15
M27x2	4
M36x2	4
M42x2	4
M48x2	6

回转头AP6 , CM2 系列



适合的活塞杆螺纹	用于系列	万向轴承-Ø [mm]	材料	物料号
M12x1,25	PRA, TRB, CVI, 167, CCI, KPZ, SSI, RPC, 102	12	钢, 镀铬	3660904000
M16x1,5	PRA, TRB, CVI, 167, CCI, KPZ, SSI, RPC, RDC, 102	16	钢, 镀铬	3660905000
M20x1,5	PRA, TRB, CVI, 167, CCI, KPZ, SSI, 102	20	钢, 镀铬	3660908000

规格

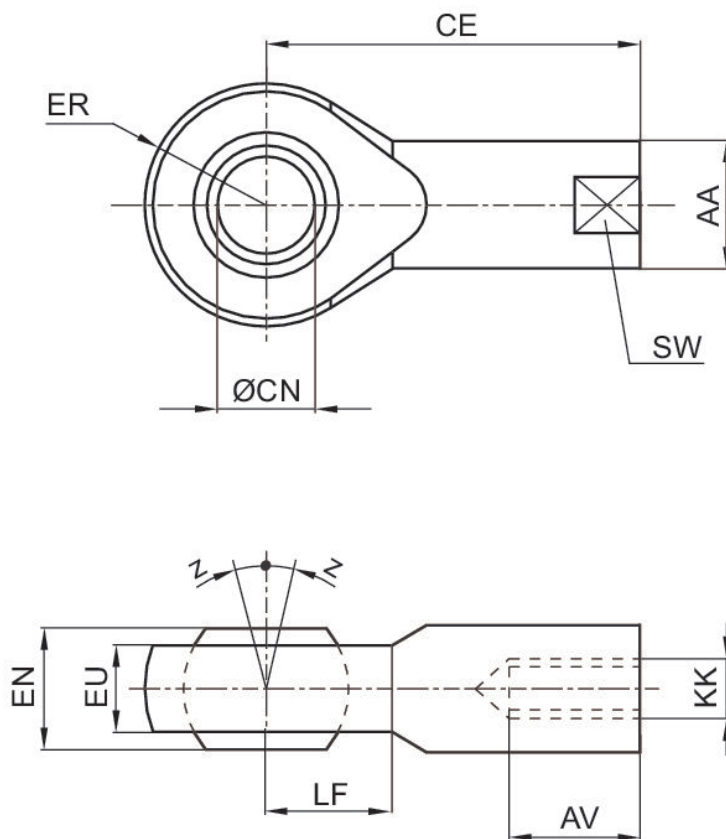

物料号	KK	AA	AV min.	CE	Ø CN H7	EN -0,1	ER	EU max.	LF	SW
3660902000	M10x1.25	19	15	43	10	12	15	9	14	17

物料号	KK	AA	AV min.	CE	Ø CN H7	EN -0,1	ER	EU max.	LF	SW
3660904000	M12x1.25	22	16	50	12	12	17	8	16	19

物料号	Z [°] max.
3660902000	8
3660904000	8

活塞杆的 螺母 MR9



螺纹尺寸	材料	物料号
M16x1,5	钢, 镀铬	1823300030
M20x1,5	钢, 镀铬	1823300031
M24x2	钢, 镀铬	8103190394
M12x1,25	不锈钢	3590304000
M16x1,5	不锈钢	3590305000
M20x1,5	不锈钢	3590308000

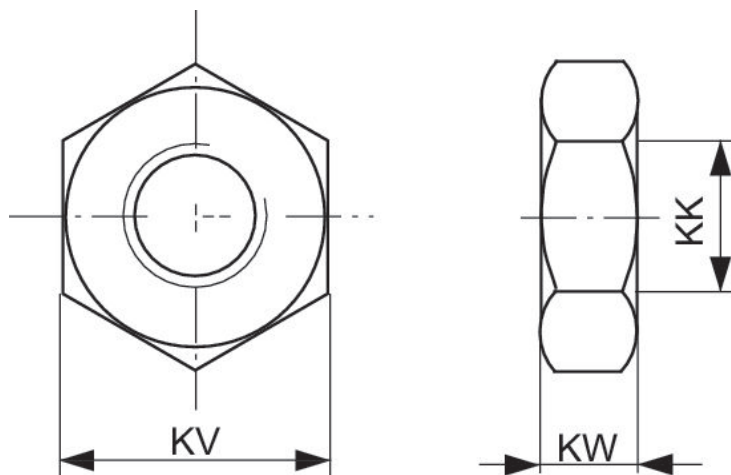

KK	物料号	KV	KW
M4	1823300033	10	3.2
M6	1823300034	13	4
M8	1823A00021	19	6
M10	8103190344	19	6
M10x1,25	1823300030	24	8
M20x1,5	1823300031	30	10
M27x2	1823A00029	41	13.5
M36x2	8103190414	50	16
M42x2	8103190424	60	21
M6	8103190644	10	3.2

KK	物料号	KV	KW
M8	8103190164	13	4
M10x1,25	8103190464	17	5
M4	3330310000	7	2.2
M12x1,25	3590304000	19	6
M16x1,5	3590305000	24	8
M20x1,5	3590308000	30	10
M20x1,5	8103040344	30	10
M24x2	8103190394	36	12
M48x2	8103190434	65	25
M10x1,25	2990600303	17	5
M12x1,25	2990600304	19	6
M16x1,5	2990600305	24	8
M20x1,5	2990600308	30	10
M27x2	2990600312	41	13.5
M36x2	2990600316	50	16
M42x2	2990600325	60	21

Efficient pneumatic solutions, our program: cylinders and drives, valves and valve systems, air supply management



Visit us: [Emerson.com/Aventics](https://www.emerson.com/Aventics)

Your local contact: [Emerson.com/contactus](https://www.emerson.com/contactus)



[Emerson.com](https://www.emerson.com)



[Facebook.com/EmersonAutomationSolutions](https://www.facebook.com/EmersonAutomationSolutions)



[LinkedIn.com/company/Emerson-Automation-Solutions](https://www.linkedin.com/company/Emerson-Automation-Solutions)



[Twitter.com/EMR_Automation](https://twitter.com/EMR_Automation)

An example configuration is depicted on the title page. The delivered product may thus vary from that in the illustration. Subject to change. This Document, as well as the data, specifications and other information set forth in it, are the exclusive property of AVENTICS GmbH. It may not be reproduced or given to third parties without its consent. Only use the AVENTICS products shown in industrial applications. Read the product documentation completely and carefully before using the product. Observe the applicable regulations and laws of the respective country. When integrating the product into applications, note the system manufacturer's specifications for safe use of the product. The data specified only serve to describe the product. No statements concerning a certain condition or suitability for a certain application can be derived from our information. The information given does not release the user from the obligation of own judgment and verification. It must be remembered that the products are subject to a natural process of wear and aging.

The Emerson logo is a trademark and service mark of Emerson Electric Co. Brand logotype are registered trademarks of one of the Emerson family of companies. All other marks are the property of their respective owners. © 2019 Emerson Electric Co. All rights reserved.



CONSIDER IT SOLVED™