

AVENTICS Series SWN Screw-in cylinders

The AVENTICS Series SWN is a cartridge cylinder and thus can be implemented in tight space.

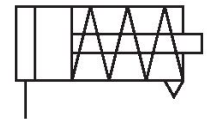
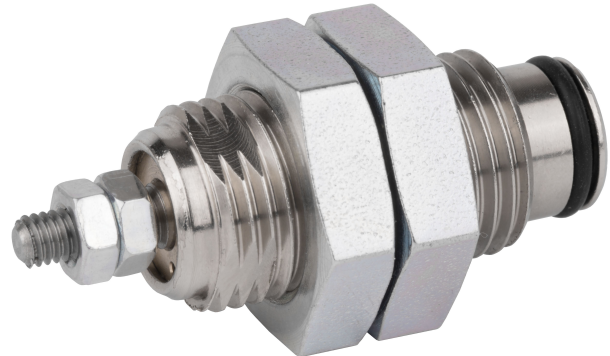

Technical data

Industry	Industrial
Type	Spring force [N] 2,1 ... 17,5
Piston Ø	16 mm
Stroke	15 mm
Functional principle	single-acting
Cushioning	Elastic cushioning
Magnetic piston	Piston without magnet
Environmental requirements	Industry standard
Piston rod thread - type	External thread
Piston rod	single
Scraper	Standard Industry Scraper
Pressure for determining piston forces	6 bar
Extracting piston force	100 N
Min. ambient temperature	-20 °C
Max. ambient temperature	80 °C
Min. working pressure	2 bar
Max. working pressure	8 bar
Weight	0.046 kg
Medium	Compressed air

Screw-in cylinder, Series SWN

Series SWN

0822406922

2024-03-14

Min. medium temperature	-20 °C
Max. medium temperature	80 °C
Max. particle size	5 µm
Min. oil content of compressed air	0 mg/m ³
Max. oil content of compressed air	1 mg/m ³

Material

Piston rod	Stainless Steel
Material, front cover	Brass
Cylinder tube	Brass
Nut for piston rod	Steel, chrome-plated
Part No.	0822406922

Technical information

The pressure dew point must be at least 15 °C less than ambient and medium temperature and may not exceed 3 °C.

The oil content of compressed air must remain constant during the life cycle.

Use only the approved oils from AVENTICS. Further information can be found in the “Technical information” document (available in <https://www.emerson.com/en-us/support>).

Screw-in cylinder, Series SWN

Series SWN

0822406922

2024-03-14

Dimensions

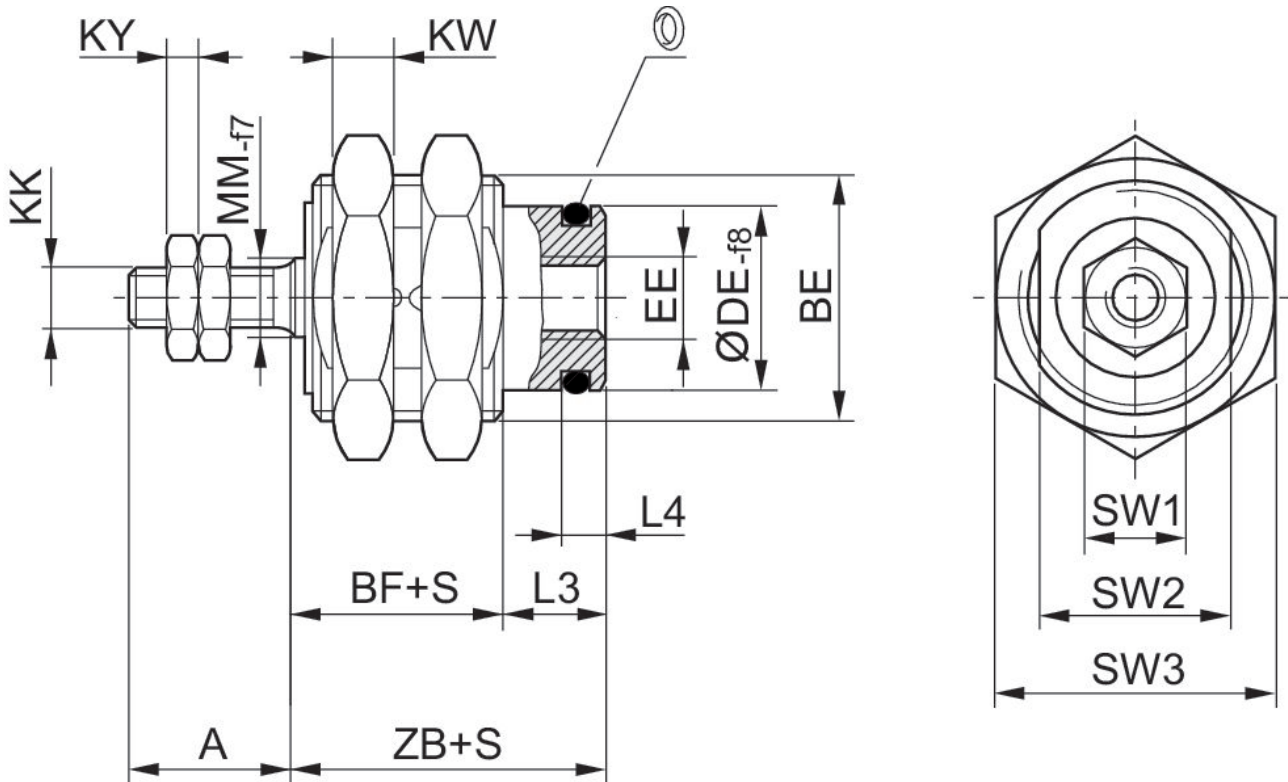

S = stroke

Part No.	Piston \varnothing	S	A	BE	BF	DE 1)	Min. spring force [N]	Spring force [N] max.	EE
0822406900	6	5	7	M10x1	8.5	7.6	2.4	4.4	M5
0822406901	6	10	7	M10x1	10.5	7.6	2.1	5.8	M5
0822406902	6	15	7	M10x1	12.5	7.6	2.3	5	M5
0822406910	10	5	10	M16x1,5	9.5	12	5.8	9.2	M5
0822406911	10	10	10	M16x1,5	11	12	4.1	7.7	M5
0822406912	10	15	10	M16x1,5	13	12	3.9	8.3	M5
0822406920	16	5	12	M22x1,5	12.8	18.5	14	17	M5
0822406921	16	10	12	M22x1,5	13.8	18.5	11.5	16.5	M5
0822406922	16	15	12	M22x1,5	15.3	18.5	8.5	17.5	M5

Part No.	Piston \varnothing	KK	KW	KY	L3	L4	MM	SW1	SW2
0822406900	6	M3	3	2.3	6	2.5	3	5.5	9
0822406901	6	M3	3	2.3	6	2.5	3	5.5	9
0822406902	6	M3	3	2.3	6	2.5	3	5.5	9
0822406910	10	M4	6	3	7	3	5	7	14
0822406911	10	M4	6	3	7	3	5	7	14
0822406912	10	M4	6	3	7	3	5	7	14
0822406920	16	M5	5	3.8	6.7	3.2	5	8	20
0822406921	16	M5	5	3.8	6.7	3.2	5	8	20

Screw-in cylinder, Series SWN

Series SWN

0822406922

2024-03-14

Part No.	Piston Ø	KK	KW	KY	L3	L4	MM	SW1	SW2
0822406922	16	M5	5	3.8	6.7	3.2	5	8	20

Part No.	Piston Ø	SW3	ZB
0822406900	6	14	14.5
0822406901	6	14	16.5
0822406902	6	14	18.5
0822406910	10	22	16.5
0822406911	10	22	18
0822406912	10	22	20
0822406920	16	27	19.5
0822406921	16	27	20.5
0822406922	16	27	22

1) Recommended receiving bore DEH7