

Mini slide, Series MSN

0821406500

AVENTICS
Series
MSN Guide
cylinders

2024-04-06

AVENTICS Series MSN Guide cylinders

The AVENTICS Series MSN mini slides offer precise guidance without play in a very narrow package. With their wide variety of mounting and air supply options the Series allows for applications in virtually any position and location.

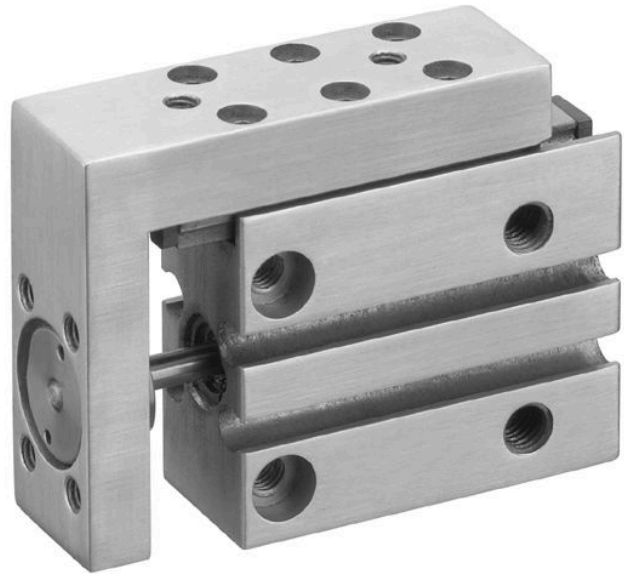

Technical data

Industry	Industrial
Note	narrow version
Piston Ø	6 mm
Stroke	5 mm
Functional principle	Double-acting
Port	M5
Cushioning	elastic
Min. working pressure	2.5 bar
Max. working pressure	10 bar
Min. ambient temperature	0 °C
Max. ambient temperature	60 °C
Medium	Compressed air
Retracting piston force, theoretical	13 N
Extracting piston force, theoretical	18 N
Max. speed	0.5 m/s
Cushioning energy	0.01 J
Min. oil content of compressed air	0 mg/m ³
Max. oil content of compressed air	1 mg/m ³
Max. particle size	5 µm
Pressure for determining piston forces with integrated ball rail guide	6,3 bar with integrated ball rail guide

Mini slide, Series MSN

0821406500

AVENTICS
Series
MSN Guide
cylinders

2024-04-06

Weight 0.071 kg

Material

Housing material	Aluminum
Surface housing	anodized
Material piston rod	Stainless Steel
Seal material	Polyurethane
Material ball rail table	Aluminum
Surface ball rail table	anodized
Material guide rail	Steel, chrome-plated
Surface guide rail	hardened
Part No.	0821406500

Technical information

The pressure dew point must be at least 15 °C less than ambient and medium temperature and may not exceed 3 °C.

The oil content of compressed air must remain constant during the life cycle.

Use only the approved oils from AVENTICS. Further information can be found in the “Technical information” document (available in <https://www.emerson.com/en-us/support>).

Mini slide, Series MSN

0821406500

MSN-6/-10/-16

AVENTICS
Series
MSN Guide
cylinders

2024-04-06

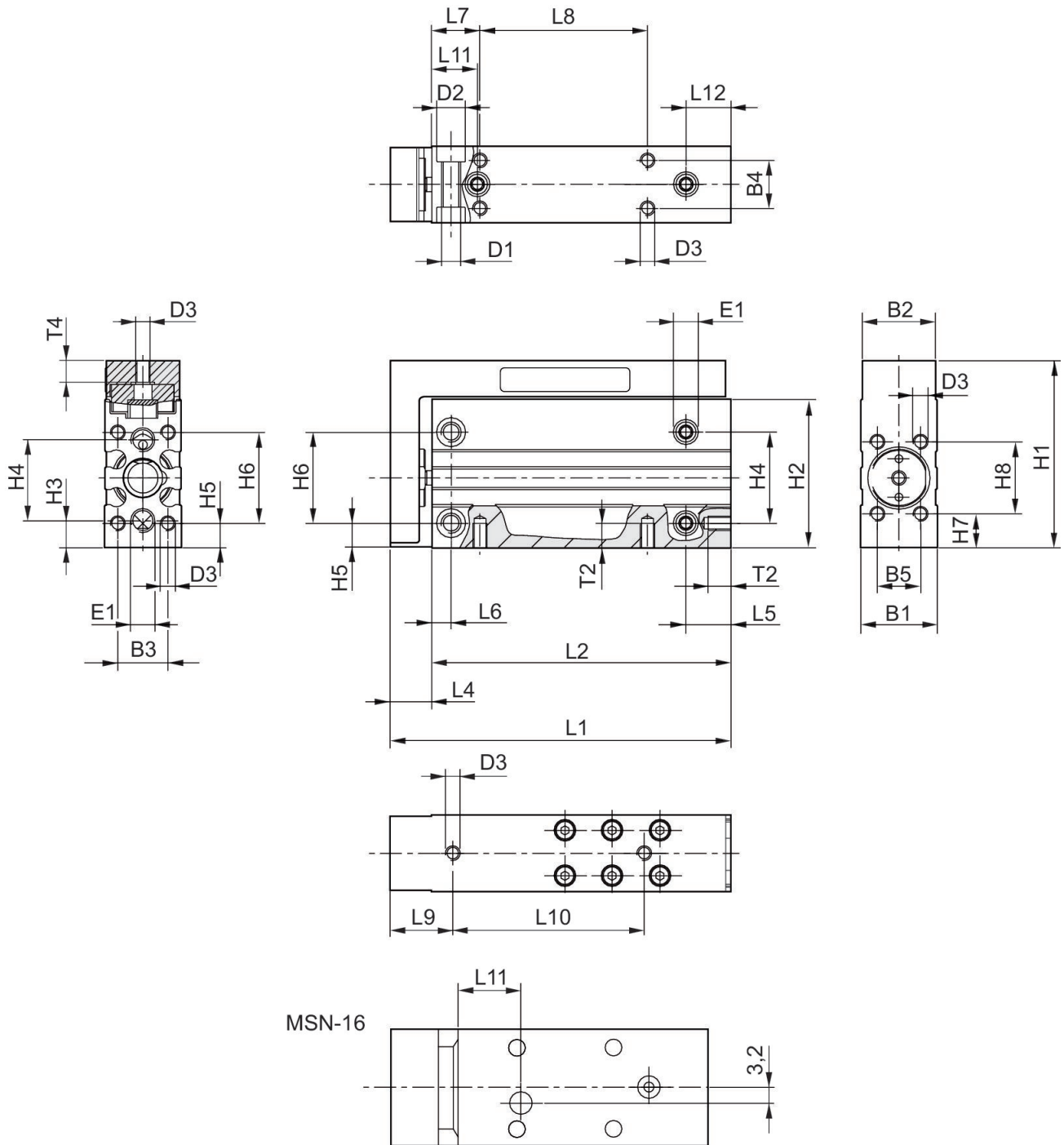

MSN-16

Part No.	Piston Ø	Stroke	L1	L2	L4	L5	L6	L7	L8
0821406512	16	5	66	52	14	12.5	5	12	20
0821406513	16	10	66	52	14	12.5	5	12	20
0821406514	16	15	76	62	14	12.5	5	12	30

Mini slide, Series MSN

0821406500

AVENTICS
Series
MSN Guide
cylinders

Part No.	Piston Ø	Stroke	L1	L2	L4	L5	L6	L7	L8
0821406515	16	20	76	62	14	12.5	5	12	30
0821406516	16	25	86	72	14	12.5	5	12	40
0821406517	16	30	91	77	14	12.5	5	12	45

Part No.	L9	L10	L11	L12	T2	T4
0821406512	18	24	13	12.5	6	6
0821406513	18	35	13	12.5	6	6
0821406514	18	45	13.5	12.5	6	6
0821406515	18	50	13.5	12.5	6	6
0821406516	18	50	17.5	12.5	6	6
0821406517	18	55	17.5	12.5	6	6

MSN-10

Part No.	Piston Ø	Stroke	L1	L2	L4	L5	L6	L7	L8
0821406506	10	5	51.5	40	11.5	12.5	5	12	10
0821406507	10	10	56.5	45	11.5	12.5	5	12	14
0821406508	10	15	61.5	50	11.5	12.5	5	12	18
0821406509	10	20	66.5	55	11.5	12.5	5	12	24
0821406510	10	25	73.5	62	11.5	12.5	5	12	32
0821406511	10	30	78.5	67	11.5	12.5	5	12	35

Part No.	L9	L10	L11	L12	T2	T4
0821406506	15	14	11	9.5	6	5.5
0821406507	15	19	11	9.5	6	5.5
0821406508	15	25	11	9.5	6	5.5
0821406509	15	30	11	9.5	6	5.5
0821406510	15	40	12	10.5	6	5.5
0821406511	15	45	12	10.5	6	5.5

MSN-6

Part No.	Piston Ø	Stroke	L1	L2	L4	L5	L6	L7	L8
0821406500	6	5	46	37.5	8.5	10	4	10	10
0821406501	6	10	51	42.5	8.5	10	4	10	15
0821406502	6	15	56	47.5	8.5	10	4	10	20
0821406503	6	20	61	52.5	8.5	10	4	10	25
0821406504	6	25	66	57.5	8.5	10	4	10	30
0821406505	6	30	71	62.5	8.5	10	4	10	35

Part No.	L9	L10	L11	L12	T2	T4
0821406500	13	20	9.5	9.5	4.8	5
0821406501	13	20	9.5	9.5	4.8	5
0821406502	13	25	9.5	9.5	4.8	5

Mini slide, Series MSN

0821406500

AVENTICS
Series
MSN Guide
cylinders

2024-04-06

Part No.	L9	L10	L11	L12	T2	T4
0821406503	13	30	9.5	9.5	4.8	5
0821406504	13	40	9.5	9.5	4.8	5
0821406505	13	40	9.5	9.5	4.8	5

MSN-6/-10/-16

Part No.	Piston Ø	B1	B2	B3	B4	B5	D1	D2	D3
0821406500	6	16	15.3	10.5	10	9	M4	6	M3
0821406501	6	16	15.3	10.5	10	9	M4	6	M3
0821406502	6	16	15.3	10.5	10	9	M4	6	M3
0821406503	6	16	15.3	10.5	10	9	M4	6	M3
0821406504	6	16	15.3	10.5	10	9	M4	6	M3
0821406505	6	16	15.3	10.5	10	9	M4	6	M3
0821406506	10	20	19.3	13	13	11	M5	7.5	M4
0821406507	10	20	19.3	13	13	11	M5	7.5	M4
0821406508	10	20	19.3	13	13	11	M5	7.5	M4
0821406509	10	20	19.3	13	13	11	M5	7.5	M4
0821406510	10	20	19.3	13	13	11	M5	7.5	M4
0821406511	10	20	19.3	13	13	11	M5	7.5	M4
0821406512	16	24	23.3	17	17	16	M5	7.5	M4
0821406513	16	24	23.3	17	17	16	M5	7.5	M4
0821406514	16	24	23.3	17	17	16	M5	7.5	M4
0821406515	16	24	23.3	17	17	16	M5	7.5	M4
0821406516	16	24	23.3	17	17	16	M5	7.5	M4
0821406517	16	24	23.3	17	17	16	M5	7.5	M4

Part No.	E1 Com-pressed air connection	H1	H2	H3	H4	H5	H6	H7	H8
0821406500	M5	39	31	5.5	17	5	19	7	15
0821406501	M5	39	31	5.5	17	5	19	7	15
0821406502	M5	39	31	5.5	17	5	19	7	15
0821406503	M5	39	31	5.5	17	5	19	7	15
0821406504	M5	39	31	5.5	17	5	19	7	15
0821406505	M5	39	31	5.5	17	5	19	7	15
0821406506	M5	45	36	6.5	20	5	23	7.5	18
0821406507	M5	45	36	6.5	20	5	23	7.5	18
0821406508	M5	45	36	6.5	20	5	23	7.5	18
0821406509	M5	45	36	6.5	20	5	23	7.5	18
0821406510	M5	45	36	6.5	20	5	23	7.5	18
0821406511	M5	45	36	6.5	20	5	23	7.5	18
0821406512	M5	51	41	6	25	5.5	27	6	26
0821406513	M5	51	41	6	25	5.5	27	6	26
0821406514	M5	51	41	6	25	5.5	27	6	26
0821406515	M5	51	41	6	25	5.5	27	6	26
0821406516	M5	51	41	6	25	5.5	27	6	26

Mini slide, Series MSN

0821406500

AVENTICS
Series
MSN Guide
cylinders

Part No.	E1 Compressed air connection	H1	H2	H3	H4	H5	H6	H7	H8
0821406517	M5	51	41	6	25	5.5	27	6	26

Correction factor (a, d) vertical

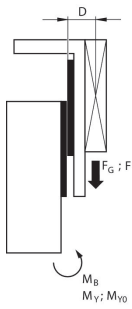

stat.	$M_{B0} = (F_G + F) \cdot D$
dyn.	$M_B = F_G \cdot D$

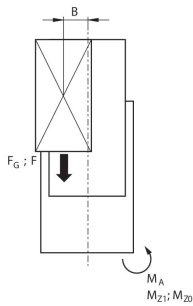

stat.	$M_{A0} = (F_G + F) \cdot B$
dyn.	$M_A = F_G \cdot B$

dyn.	$\frac{M_A}{M_1} + \frac{M_B}{M_2} \leq 1$
stat.	$\frac{M_{A0}}{M_{Z0}} + \frac{M_{B0}}{M_{Y0}} \leq 1$

Correction factor (a, d) horizontal

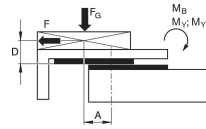

stat.	$M_{B0} = F_G \cdot A + F \cdot D$
dyn.	$M_B = F_G \cdot A$

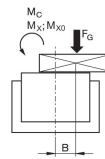

stat.	$M_{C0} = F_G \cdot B$
dyn.	$M_C = F_G \cdot B$

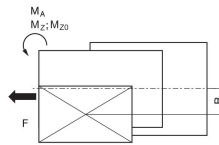

stat.	$M_{A0} = F \cdot B$
dyn.	$M_A = 0$

dyn.	$\frac{M_A}{M_1} + \frac{M_B}{M_2} + \frac{M_C}{M_3} \leq 1$
stat.	$\frac{M_{A0}}{M_{Z0}} + \frac{M_{B0}}{M_{Y0}} + \frac{M_{C0}}{M_{X0}} \leq 1$

$F = m \cdot a$ $FG = m \cdot g$ $a = 1250 \cdot V^2 / H$
 F = deceleration force [N] F_G = force due to weight [N] m = load mass [kg] a = deceleration [m/s²] g = gravitational acceleration 9,81 [m/s²] V = velocity [m/s] H = stroke length of shock absorber [mm]

$F = m \cdot a$ $FG = m \cdot g$ $a = 1250 \cdot V^2 / H$
 F = deceleration force [N] F_G = force due to weight [N] m = load mass [kg] a = deceleration [m/s²] g = gravitational acceleration 9,81 [m/s²] V = velocity [m/s] H = stroke length of shock absorber [mm]

Mini slide, Series MSN

0821406500

AVENTICS

Series

MSN Guide

cylinders

2024-04-06

M = max. permissible torque

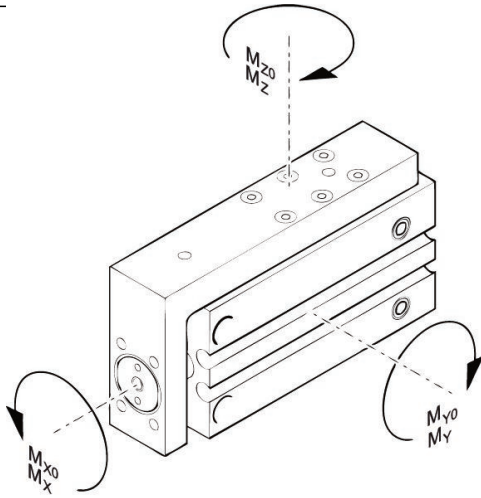

Maximum additionally moving mass
(min. stroke, max. stroke)

MSN - 6

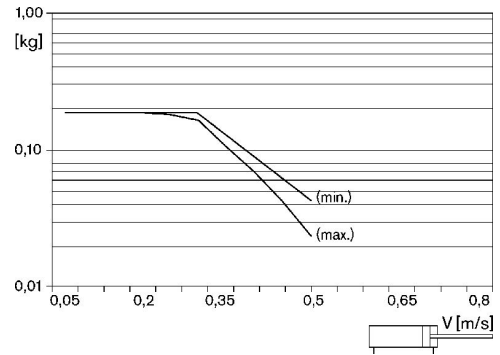

Maximum additionally moving mass
(min. stroke, max. stroke)

MSN - 10

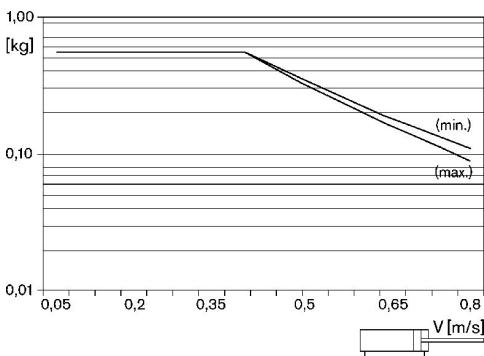

Maximum additionally moving mass
(min. stroke, max. stroke)

MSN-16

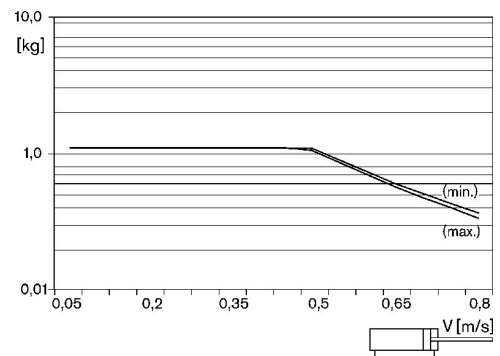

Correction factor (a, d)

Mini slide, Series MSN

0821406500

AVENTICS
Series
MSN Guide
cylinders

2024-04-06

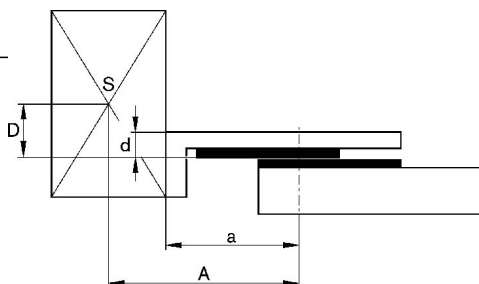

Correction factor (a, d)

Part No.	Piston \varnothing	Stroke	a [mm]	d [mm]	Mx0 Static moment M [Nm]	My0 Static moment M [Nm]	Mz0 Static moment M [Nm]	Mx Dynam-ic moment M [Nm]	My Dynam-ic moment M [Nm]
0821406500	6	5	27	6	3	3.2	3.2	0.6	0.9
0821406501	6	10	32	6	3	3.2	3.2	0.6	0.9
0821406502	6	15	32	6	3	3.2	3.2	0.6	0.9
0821406503	6	20	37	6	3	3.2	3.2	0.6	0.9
0821406504	6	25	42	6	3	3.2	3.2	0.6	0.9
0821406505	6	30	47	6	3	3.2	3.2	0.6	0.9
0821406506	10	5	31	6.8	2.3	2.4	2.4	0.6	0.8
0821406507	10	10	36	6.8	2.3	2.4	2.4	0.6	0.8
0821406508	10	15	41	6.8	2.3	2.4	2.4	0.6	0.8
0821406509	10	20	41	6.8	3.2	3.3	3.3	0.7	1.2
0821406510	10	25	48	6.8	3.2	3.3	3.3	0.7	1.2
0821406511	10	30	53	6.8	3.2	3.3	3.3	0.7	1.2
0821406512	16	5	40	7.5	6.8	6.9	6.9	1.7	2.1
0821406513	16	10	40	7.5	6.8	6.9	6.9	1.7	2.1
0821406514	16	15	50	7.5	6.8	6.9	6.9	1.7	2.1
0821406515	16	20	50	7.5	6.8	6.9	6.9	1.7	2.1
0821406516	16	25	55	7.5	10	12.3	12.3	1.9	2.7
0821406517	16	30	60	7.5	10	12.3	12.3	1.9	2.7

Part No.	Mz Dynam-ic moment M [Nm]
0821406500	0.9
0821406501	0.9
0821406502	0.9
0821406503	0.9
0821406504	0.9
0821406505	0.9
0821406506	0.8
0821406507	0.8
0821406508	0.8
0821406509	1.2
0821406510	1.2
0821406511	1.2

Mini slide, Series MSN

0821406500

AVENTICS
Series
MSN Guide
cylinders

2024-04-06

Part No.	Mz Dynamic moment M [Nm]
0821406512	2.1
0821406513	2.1
0821406514	2.1
0821406515	2.1
0821406516	2.7
0821406517	2.7

Overview drawing

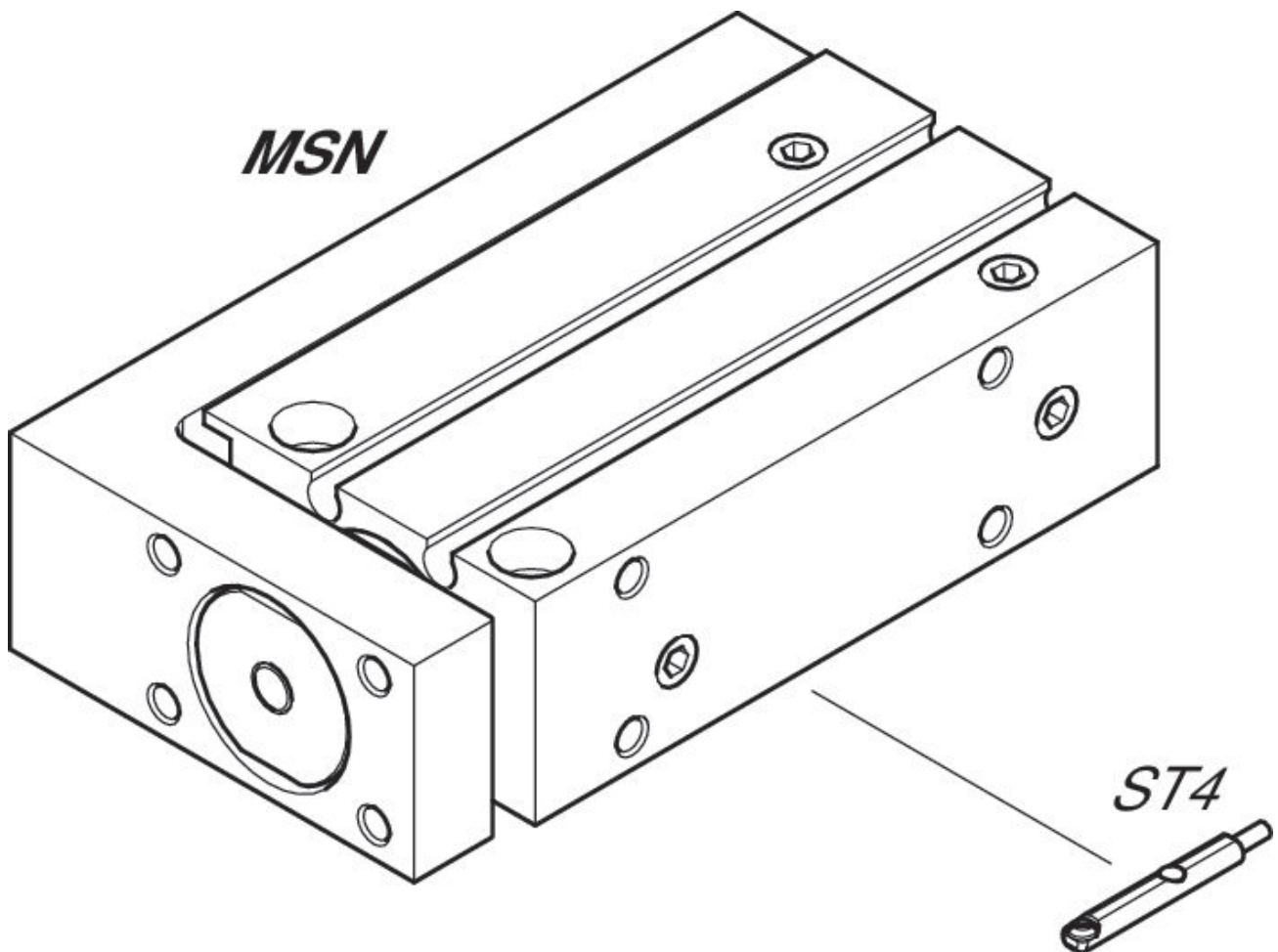

NOTE: This overview drawing is only for orientation to indicate where the various accessory parts can be fastened to the cylinder. The illustration has been simplified for this purpose. It is thus not possible to derive the dimensions from this overview.