

AVENTICS Series NL4 Air Preparation Units

The AVENTICS Series NL maintenance units are suitable for all areas: as individual components or as assembled maintenance units, for centralized or decentralized compressed air preparation, in compact or powerful versions, for use in high or low temperatures. This line offers a complete, customizable compressed air preparation technology. It includes an option to combine every component in the Series to achieve the desired function, making it possible to adjust the components precisely to the application requirements.

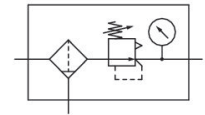

Technical data

Industry	Industrial
Parts	Filter pressure regulator
Reservoir	reservoir, polycarbonate, with metal protective guard
Port	G 1/2
Nominal flow Qn	6900 l/min
Filter porosity	5 µm
Condensate drain	semi-automatic, open without pressure
Pressure gauge	with pressure gauge
Min. working pressure	1.5 bar
Max. working pressure	16 bar
Min. ambient temperature	-10 °C
Max. ambient temperature	60 °C
Min. regulation range	0.5 bar
Max. regulation range	10 bar
Lock type	Standard locking, with key
Type	1-part
Type	Can be assembled into blocks
Pressure supply	single
Mounting orientation	vertical

Filter pressure regulator, Series NL4-FRE

NL4

0821300234

2024-04-24

Regulator type	Diaphragm-type pressure regulator
Regulator function	with relieving air exhaust
Filter element	exchangeable
Filter reservoir volume	50 cm ³
Max. achievable compressed air class acc. to ISO 8573-1:2010	6 : 7 : -
Medium	Compressed air Neutral gases
Weight	2.1 kg

Material

Housing material	Die cast zinc
Seal material	Acrylonitrile butadiene rubber
Material front plate	Acrylonitrile butadiene styrene
Material threaded bushing	Die cast zinc
Material reservoir	Polycarbonate
Material protective guard	Steel, chrome-plated
Material filter insert	Polyethylene
Part No.	0821300234

Technical information

The pressure dew point must be at least 15 °C less than ambient and medium temperature and may not exceed 3 °C.

Note: Polycarbonate reservoirs are susceptible to solvents, supplementary information can be found at "Customer information".

A change in the flow direction (from air supply on the left to air supply on the right) occurs by rotating installation by 180° about the vertical axis. Please see the operating instructions for further details.

Also suitable for separation of fluid oil or water due to the design.

The rear pressure gauge connection on the pressure regulator is closed with a blanking plug, the front connection is open. Depending on the customer application, a second blanking plug may be necessary. Please order separately (see accessories).

Nominal flow Q_n with secondary pressure p₂ = 6 bar at Δp = 1 bar

Metal protective guard can be retrofitted for all polycarbonate reservoirs

Pressure gauge enclosed separately

Filter pressure regulator, Series NL4-FRE

NL4

0821300234

2024-04-24

Dimensions

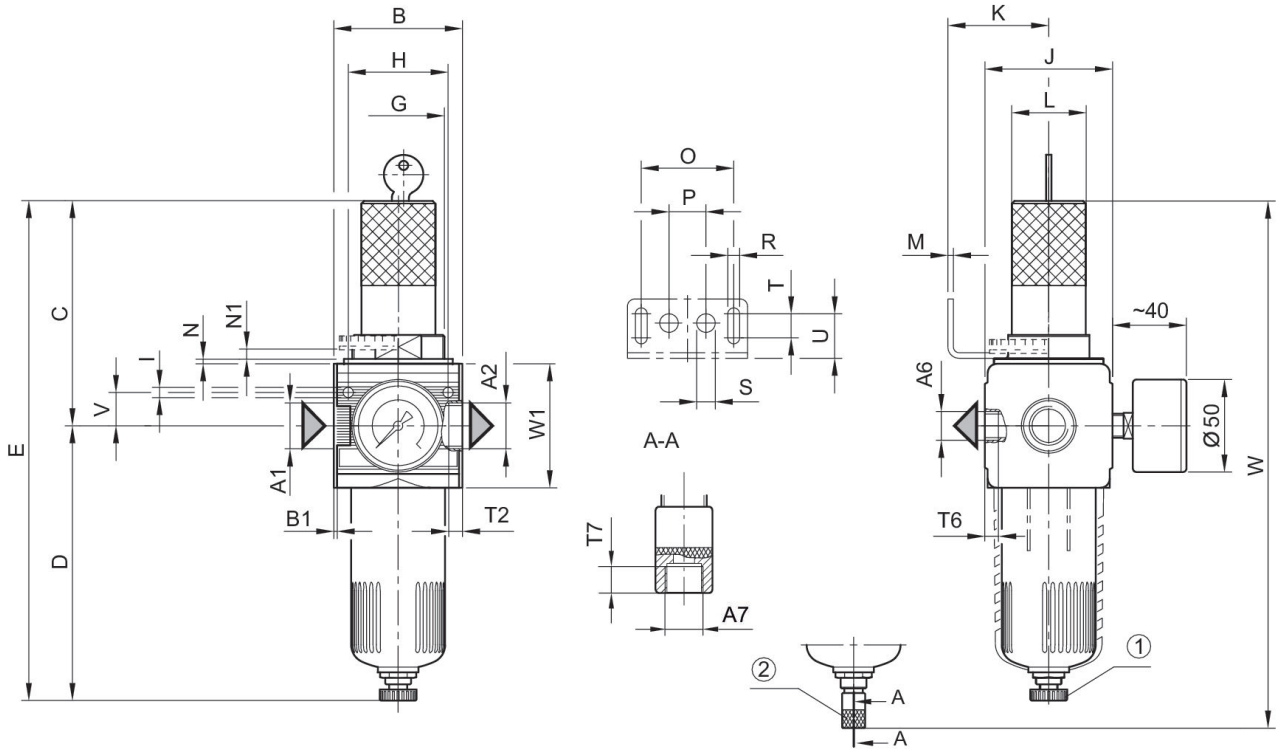

A1 = input A2 = output A6 = output

A7 = condensate drain

1) Semi-automatic condensate drain 2) fully automatic condensate drain

Dimensions in mm

Part No.	A1	A2	A6	A7	B	B1	C	D	E
0821300356	G 1/2	G 1/2	G 1/4	G 1/8	69.6	1.8	122	146.5	268.5
0821300234	G 1/2	G 1/2	G 1/4	G 1/8	69.6	1.8	122	146.5	268.5
0821300235	G 1/2	G 1/2	G 1/4	G 1/8	69.6	1.8	122	146.5	268.5
0821300236	G 1/2	G 1/2	G 1/4	G 1/8	69.6	1.8	122	146.5	268.5
0821300237	G 1/2	G 1/2	G 1/4	G 1/8	69.6	1.8	122	146.5	268.5
0821300238	G 1/2	G 1/2	G 1/4	G 1/8	69.6	1.8	122	146.5	268.5
0821300386	G 3/4	G 3/4	G 1/4	G 1/8	69.6	1.8	122	146.5	268.5
0821300239	G 3/4	G 3/4	G 1/4	G 1/8	69.6	1.8	122	146.5	268.5
0821300240	G 3/4	G 3/4	G 1/4	G 1/8	69.6	1.8	122	146.5	268.5
0821300241	G 3/4	G 3/4	G 1/4	G 1/8	69.6	1.8	122	146.5	268.5
0821300243	G 3/4	G 3/4	G 1/4	G 1/8	69.6	1.8	122	146.5	268.5

Part No.	G	H	I	J	K	L	M	N	N1
0821300356	M50x1,5	54	5.5	69	54.5	46	3		5.5
0821300234	M50x1,5	54	5.5	69	54.5	46	3		5.5
0821300235	M50x1,5	54	5.5	69	54.5	46	3		5.5
0821300236	M50x1,5	54	5.5	69	54.5	46	3		5.5
0821300237	M50x1,5	54	5.5	69	54.5	46	3		5.5

Filter pressure regulator, Series NL4-FRE

NL4

0821300234

2024-04-24

Part No.	G	H	I	J	K	L	M	N	N1
0821300238	M50x1,5	54	5.5	69	54.5	46	3		5.5
0821300386	M50x1,5	54	5.5	69	54.5	46	3	3	5.5
0821300239	M50x1,5	54	5.5	69	54.5	46	3	3	5.5
0821300240	M50x1,5	54	5.5	69	54.5	46	3	3	5.5
0821300241	M50x1,5	54	5.5	69	54.5	46	3	3	5.5
0821300243	M50x1,5	54	5.5	69	54.5	46	3	3	5.5

Part No.	O	P	R	S	T	T2	T6	T7	U
0821300356	50	20	6.4	10	13	13	7	8.5	24
0821300234	50	20	6.4	10	13	13	7	8.5	24
0821300235	50	20	6.4	10	13	13	7	8.5	24
0821300236	50	20	6.4	10	13	13	7	8.5	24
0821300237	50	20	6.4	10	13	13	7	8.5	24
0821300238	50	20	6.4	10	13	13	7	8.5	24
0821300386	50	20	6.4	10	13	13	7	8.5	24
0821300239	50	20	6.4	10	13	13	7	8.5	24
0821300240	50	20	6.4	10	13	13	7	8.5	24
0821300241	50	20	6.4	10	13	13	7	8.5	24
0821300243	50	20	6.4	10	13	13	7	8.5	24

Part No.	V	W	W1
0821300356	18	286.5	67
0821300234	18	286.5	67
0821300235	18	286.5	67
0821300236	18	286.5	67
0821300237	18	286.5	67
0821300238	18	286.5	67
0821300386	18	286.5	67
0821300239	18	286.5	67
0821300240	18	286.5	67
0821300241	18	286.5	67
0821300243	18	286.5	67

Flow rate characteristic, $p_2 = 0,05 - 7$ bar Pressure characteristics curve

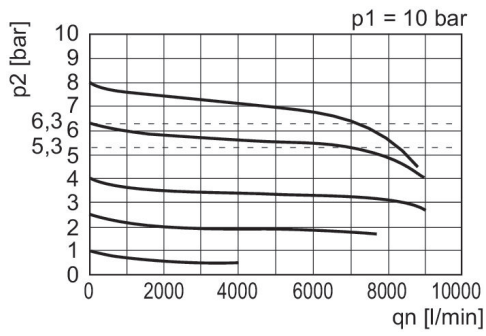

p_1 = Working pressure p_2 = Secondary pressure q_n = Nominal flow

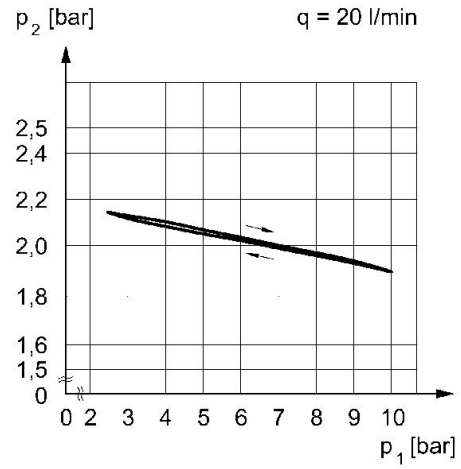

p_1 = working pressure p_2 = secondary pressure q = flow rate